

Pioneer

Operating Instructions

audio/video multi-channel receiver

SC-9540

FEDERAL COMMUNICATIONS COMMISSION DECLARATION OF CONFORMITY

This device complies with part 15 of the FCC Rules. Operation is subject to the following two conditions: (1) This device may not cause harmful interference, and (2) this device must accept any interference received, including interference that may cause undesired operation.

Product Name: AUDIO/VIDEO MULTI-CHANNEL RECEIVER
Model Number: SC-9540
Responsible Party Name: PIONEER ELECTRONICS SERVICE, INC.
Address: 1925 E. DOMINGUEZ ST. LONG BEACH, CA 90801-1760, U.S.A.
Phone: 1-800-421-1404

IMPORTANT NOTICE

THE SERIAL NUMBER FOR THIS EQUIPMENT IS LOCATED IN THE REAR.
PLEASE WRITE THIS SERIAL NUMBER ON YOUR ENCLOSED WARRANTY CARD AND KEEP IN A SECURE AREA.
THIS IS FOR YOUR SECURITY.

D1-4-2-6-1*_A1_En

NOTE:

This equipment has been tested and found to comply with the limits for a Class B digital device, pursuant to Part 15 of the FCC Rules. These limits are designed to provide reasonable protection against harmful interference in a residential installation. This equipment generates, uses, and can radiate radio frequency energy and, if not installed and used in accordance with the instructions, may cause harmful interference to radio communications. However, there is no guarantee that interference will not occur in a particular installation. If this equipment does cause harmful interference to radio or television reception, which can be determined by turning the equipment off and on, the user is encouraged to try to correct the interference by one or more of the following measures:

- Reorient or relocate the receiving antenna.
- Increase the separation between the equipment and receiver.
- Connect the equipment into an outlet on a circuit different from that to which the receiver is connected.
- Consult the dealer or an experienced radio/TV technician for help.

D8-10-1-2_A1_En

CAUTION

This product satisfies FCC regulations when shielded cables and connectors are used to connect the unit to other equipment. To prevent electromagnetic interference with electric appliances such as radios and televisions, use shielded cables and connectors for connections.

D8-10-3a_A1_En

This Class B digital apparatus complies with Canadian ICES-003.

D8-10-1-3_A1_En

Information to User

Alterations or modifications carried out without appropriate authorization may invalidate the user's right to operate the equipment.

D8-10-2_A1_En

CAUTION

The **STANDBY/ON** switch on this unit will not completely shut off all power from the AC outlet. Since the power cord serves as the main disconnect device for the unit, you will need to unplug it from the AC outlet to shut down all power. Therefore, make sure the unit has been installed so that the power cord can be easily unplugged from the AC outlet in case of an accident. To avoid fire hazard, the power cord should also be unplugged from the AC outlet when left unused for a long period of time (for example, when on vacation).

D3-4-2-2a_A_En

VENTILATION CAUTION

When installing this unit, make sure to leave space around the unit for ventilation to improve heat radiation (at least 20 cm at top, 10 cm at rear, and 20 cm at each side).

WARNING

Slots and openings in the cabinet are provided for ventilation to ensure reliable operation of the product, and to protect it from overheating. To prevent fire hazard, the openings should never be blocked or covered with items (such as newspapers, table-cloths, curtains) or by operating the equipment on thick carpet or a bed.

D3-4-2-1-7b_A_En

Operating Environment

Operating environment temperature and humidity:
+5 °C to +35 °C (+41 °F to +95 °F); less than 85 %RH
(cooling vents not blocked)

Do not install this unit in a poorly ventilated area, or in locations exposed to high humidity or direct sunlight (or strong artificial light)

D3-4-2-1-7c*_A1_En

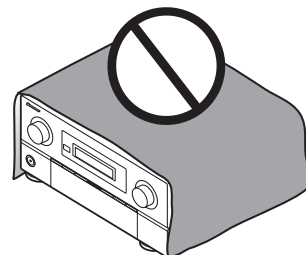

IMPORTANT



The lightning flash with arrowhead symbol, within an equilateral triangle, is intended to alert the user to the presence of uninsulated "dangerous voltage" within the product's enclosure that may be of sufficient magnitude to constitute a risk of electric shock to persons.

CAUTION

**RISK OF ELECTRIC SHOCK
DO NOT OPEN**

CAUTION:
TO PREVENT THE RISK OF ELECTRIC SHOCK, DO NOT REMOVE COVER (OR BACK). NO USER-SERVICEABLE PARTS INSIDE. REFER SERVICING TO QUALIFIED SERVICE PERSONNEL.



The exclamation point within an equilateral triangle is intended to alert the user to the presence of important operating and maintenance (servicing) instructions in the literature accompanying the appliance.

D3-4-2-1-1_A1_En

IMPORTANT SAFETY INSTRUCTIONS

- 1) Read these instructions.
- 2) Keep these instructions.
- 3) Heed all warnings.
- 4) Follow all instructions.
- 5) Do not use this apparatus near water.
- 6) Clean only with dry cloth.
- 7) Do not block any ventilation openings. Install in accordance with the manufacturer's instructions.
- 8) Do not install near any heat sources such as radiators, heat registers, stoves, or other apparatus (including amplifiers) that produce heat.
- 9) Do not defeat the safety purpose of the polarized or grounding-type plug. A polarized plug has two blades with one wider than the other. A grounding type plug has two blades and a third grounding prong. The wide blade or the third prong are provided for your safety. If the provided plug does not fit into your outlet, consult an electrician for replacement of the obsolete outlet.
- 10) Protect the power cord from being walked on or pinched particularly at plugs, convenience receptacles, and the point where they exit from the apparatus.

- 11) Only use attachments/accessories specified by the manufacturer.
- 12) Use only with the cart, stand, tripod, bracket, or table specified by the manufacturer, or sold with the apparatus. When a cart is used, use caution when moving the cart/apparatus combination to avoid injury from tip-over.



- 13) Unplug this apparatus during lightning storms or when unused for long periods of time.
- 14) Refer all servicing to qualified service personnel. Servicing is required when the apparatus has been damaged in any way, such as power-supply cord or plug is damaged, liquid has been spilled or objects have fallen into the apparatus, the apparatus has been exposed to rain or moisture, does not operate normally, or has been dropped.

P1-4-2-2_En

WARNING

This equipment is not waterproof. To prevent a fire or shock hazard, do not place any container filled with liquid near this equipment (such as a vase or flower pot) or expose it to dripping, splashing, rain or moisture.

D3-4-2-1-3_B_En

WARNING

Before plugging in for the first time, read the following section carefully.

The voltage of the available power supply differs according to country or region. Be sure that the power supply voltage of the area where this unit will be used meets the required voltage (e.g., 230 V or 120 V) written on the rear panel.

D3-4-2-1-4_A_En

This product is for general household purposes. Any failure due to use for other than household purposes (such as long-term use for business purposes in a restaurant or use in a car or ship) and which requires repair will be charged for even during the warranty period.

K041_En

CAUTION

To prevent fire hazard, the Class 2 Wiring Cable should be used for connection with speaker, and should be routed away from hazards to avoid damage to the insulation of the cable.

WARNING

To prevent a fire hazard, do not place any naked flame sources (such as a lighted candle) on the equipment.

D3-4-2-1-7a_A_En

WARNING: Handling the cord on this product or cords associated with accessories sold with the product will expose you to chemicals listed on proposition 65 known to the State of California and other governmental entities to cause cancer and birth defect or other reproductive harm.

Wash hands after handling

D36-P4_A_En

If the AC plug of this unit does not match the AC outlet you want to use, the plug must be removed and appropriate one fitted. Replacement and mounting of an AC plug on the power supply cord of this unit should be performed only by qualified service personnel. If connected to an AC outlet, the cut-off plug can cause severe electrical shock. Make sure it is properly disposed of after removal.

The equipment should be disconnected by removing the mains plug from the wall socket when left unused for a long period of time (for example, when on vacation).

D3-4-2-2-1a_A_En



Thank you for buying this Pioneer product. Please read through these operating instructions so you will know how to operate your model properly. After you have finished reading the instructions, put them away in a safe place for future reference.

Contents

Flow of settings on the receiver 8

01 Before you start

Our philosophy	9
Features.....	9
Checking what's in the box	10
Installing the receiver	10
Loading the batteries.....	11
Operating range of remote control unit	11

02 Controls and displays

Remote control	12
Front panel	14
Display.....	15

03 Connecting your equipment

Rear panel	17
Determining the speakers' application	19
Other speaker connection	19
Placing the speakers	20
THX speaker system setup	20
Some tips for improving sound quality	20
Connecting the speakers.....	21
Installing your speaker system.....	22
Standard 5.1/6.1/7.1-channel surround connections	22
Bi-amping your speakers.....	23
Bi-wiring your speakers.....	23
Selecting the Surr Back system.....	24
ZONE 2 setup	24
Speaker B setup	24
Bi-Amping setup.....	24
About the audio connection.....	24
About the video converter	25
Connecting your TV and playback components.....	26
Connecting using HDMI	26
Connecting your DVD player with no HDMI output	27
Connecting your TV with no HDMI input	28
Connecting an HDD/DVD recorder, VCR and other video sources	30
Connecting a satellite/cable receiver or other set-top box.....	31
Connecting the multichannel analog inputs	31
Connecting other audio components.....	32
About the WMA9 Pro decoder.....	32
Connecting additional amplifiers.....	33
Connecting AM/FM antennas	33
Connecting external antennas.....	34
Connecting an XM Radio tuner	34
Connecting a SiriusConnect™ tuner	34
MULTI-ZONE setup	35
Making MULTI-ZONE connections.....	35
Connecting an IR receiver	37

Operating other Pioneer components with this unit's sensor	37
Switching components on and off using the 12 volt trigger	38
Connecting a PC for Advanced MCACC output	38
Connecting an HDMI-equipped component to the front panel input	39
Connecting an iPod.....	40
Connecting a USB device	40
Plugging in the receiver.....	41

04 Basic Setup

Changing the OSD display language (OSD Language)	42
Automatically setting up for surround sound (Auto MCACC & Full Band Phase Control)	42
Problems when using the Auto MCACC Setup	44
The Input Setup menu.....	44
Input function default and possible settings	45

05 Basic playback

Playing a source	46
Playing a source with HDMI connection	46
Selecting the multichannel analog inputs.....	47
Playing an iPod	47
Playing back audio files stored on an iPod	47
Playing a USB device.....	49
Playing back audio files stored on a USB memory device	49
Playing back photo files stored on a USB memory device	50
About playable file formats	51
Listening to the radio.....	52
Improving FM sound.....	52
Using the noise cut mode	52
Using Neural THX.....	52
Tuning directly to a station	52
Saving station presets.....	52
Naming station presets.....	52
Listening to station presets	53
Listening to Satellite Radio	53
Listening to XM Radio	53
Using XM HD Surround	54
Saving channel presets.....	54
Using the XM Menu	54
Listening to SIRIUS Radio	55
Saving channel presets.....	56
Using the SIRIUS Menu	56

06 Listening to your system

Auto playback	57
Listening in surround sound	57
Standard surround sound	57
Using the Home THX modes	58
Using the Advanced surround effects	59
Listening in stereo	59
Using Front Stage Surround Advance	60
Using Stream Direct	60
Using surround back channel processing	61
Using the Virtual Surround Back mode	61
Setting the Up Mix function	62
Selecting MCACC presets	62
Choosing the input signal	63
Better sound using Phase Control and Full Band	
Phase Control	63
Using Phase Control	63
Using Full Band Phase Control	64

07 Playback with HOME MEDIA GALLERY inputs

Enjoying the Home Media Gallery	66
Features of Home Media Gallery	66
Steps to enjoy the Home Media Gallery	66
Playing back audio files on the network and listening to Internet radio stations	66
Connecting to the network through LAN interface	67
Introduction	67
About network playback	68
Windows Media Player	68
Windows Media DRM	68
DLNA	68
Content playable over a network	68
About playback behavior over a network	68
Authorizing this receiver	68
Playback with Home Media Gallery	69
Playing back audio files stored on components on the network	70
Listening to Internet radio stations	70
Listening to Rhapsody	72
Listening to Sirius Internet Radio	72
Listening to Neural Music Direct	72
Playing back your favorite songs	72
About playable file formats	73
Advanced operations for Internet radio	74
Saving Internet radio stations	74
Retrieving saved Internet radio stations	74
Setting up the network	74
Checking the network settings	76
Checking about the Accounts	76
Software update	76
Glossary	77

08 KURO LINK

Making the KURO LINK connections	79
Cautions on the KURO LINK function	79
About connections with a product of a different brand that supports the KURO LINK function	80
KURO LINK Setup	80
Setting the PQLS function	81
Before using synchronization	81
Synchronized amp mode	81
Synchronized amp mode operations	81
Canceling synchronized amp mode	81

09 Using other functions

Setting the Audio options	82
Setting the Video options	83
Switching the speaker system	84
Using the MULTI-ZONE controls	85
Making an audio or a video recording	86
Reducing the level of an analog signal	86
Using the sleep timer	86
Dimming the display	87
Switching the HDMI output	87
Checking your system settings	87
Resetting the system	88
Default system settings	88

10 Controlling the rest of your system

Operating multiple receivers	89
Setting the remote to control other components	89
Selecting preset codes directly	89
Programming signals from other remote controls	90
Erasing the remote control button settings	90
Multi Operation and System Off	91
Programming a multi-operation	91
Using multi operations	91
Using System off	92
Resetting the remote control presets	92
Default preset codes	92
Controls the components	92

11 The Advanced MCACC menu

Making receiver settings from the Advanced MCACC menu	95
Automatic MCACC (Expert)	96
Manual MCACC setup	98
Fine Channel Level	99
Fine Speaker Distance	100
Standing Wave	100
Acoustic Calibration EQ Adjust	101
Acoustic Calibration EQ Professional	101
Checking MCACC Data	104
Speaker Setting	104
Channel Level	104
Speaker Distance	105
Standing Wave	105
Acoustic Cal EQ	105
Group Delay	105
Output PC	106
Data Management	106
Renaming MCACC presets	107
Copying MCACC preset data	107
Clearing MCACC presets	107

12 The system and the other setup

Making receiver settings from the System Setup menu	108
Manual speaker setup	108
Surround back speaker setting	109
Speaker Setting	109
Channel Level	110
Speaker Distance	111
X-Curve	111
THX Audio Setting	111
The Other Setup menu	112
Multi Channel Input Setup	112
ZONE Audio Setup	113
Power ON Level Setup	113
Volume Limit Setup	113
Remote Control Mode Setup	114
Flicker Reduction Setup	114

13 Additional information

Speaker Setting Guide	115
Positional relationship between speakers and monitor	116
Troubleshooting	116
Power	116
No sound	117
Other audio problems	118
Video	119
Settings	120
Professional Calibration EQ graphical output	120
Display	121
Remote control	121
HDMI	122
Important information regarding the HDMI connection	123
HOME MEDIA GALLERY	123
About status messages	125
USB interface	125
XM radio messages	126
SIRIUS radio messages	127
Surround sound formats	127
Dolby	127
DTS	128
Windows Media Audio 9 Professional	129
About iPod	129
About THX	129
About Neural – THX Surround	131
About SIRIUS and XM	131
About FLAC	132
FLAC Decoder	132
Auto Surround, ALC and Stream Direct with different input signal formats	133
Specifications	134
Cleaning the unit	134
Index	135

Flow of settings on the receiver

The unit is a full-fledged AV receiver equipped with an abundance of functions and terminals. It can be used easily after following the procedure below to make the connections and settings.

The colors of the steps indicate the following:

Required setting item

Setting to be made as necessary

1 Before you start

- Checking what's in the box (page 10)
- Loading the batteries (page 11)



2 Determining the speakers' application (page 19)

- 7.1ch surround connection
- 5.1ch surround & Front Bi-amping connection
- 5.1ch surround & ZONE 2 connection
- 5.1ch surround & Speaker B connection



3 Connecting the speakers

- Placing the speakers (page 20)
- Connecting the speakers (page 21)
- Standard 5.1/6.1/7.1-channel surround connections (page 22)
- Bi-amping your speakers (page 23)



4 Connecting the components

- About the audio connection (page 24)
- About the video converter (page 25)
- Connecting your TV and playback components (page 26)
- Connecting AM/FM antennas (page 33)
- Plugging in the receiver (page 41)



5 Power On



6 Changing the OSD display language (OSD Language) (page 42)



7 Surround back speaker setting (page 109)



8 MCACC speaker settings

- Automatically setting up for surround sound (Auto MCACC & Full Band Phase Control) (page 42)



9 The Input Setup menu (page 44)

(When using connections other than the recommended connections)



10 Basic playback (page 46)



11 Switching the HDMI output (page 87)



12 Adjusting the sound and picture quality as desired

- Using the various listening modes
- Using surround back channel processing (page 61)
- Better sound using Phase Control and Full Band Phase Control (page 63)
- Measure the all EQ type (SYMMETRY/ALL CH ADJ/FRONT ALIGN) (page 96)
- Change the channel level while listening (*Tip* on page 110)
- Switches on/off the Acoustic Calibration EQ, Sound retriever or Dialog Enhancement (page 82)
- Setting the PQLS function (page 81)
- Setting the Audio options (Tone, Loudness or Sound delay, etc.) (page 82)
- Setting the Video options (page 83)



13 Other optional adjustments and settings

- KURO LINK Setup (page 80)
- The Advanced MCACC menu (page 95)
- The system and the other setup (page 108)



14 Making maximum use of the remote control

- Operating multiple receivers (page 89)
- Setting the remote to control other components (page 89)

Chapter 1: Before you start

Our philosophy

Pioneer is dedicated to making your home theater listening experience as close as possible to the vision of the moviemakers and mastering engineer when they created the original soundtrack. We do this by focusing on three important steps:

- 1 **Achieving the highest possible sound quality**
- 2 **Allowing for customized acoustic calibration according to any listening area**
- 3 **Fine-tuning the receiver with the help of world-class studio engineers¹**

¹ *With the cooperation of AIR Studios, this receiver has been designated AIR Studios Monitor.*



Features

- **Direct Energy HD Amplifier**

Through a collaboration, Pioneer and ICEpower have jointly developed a unique class D amplifier called a "Direct Energy High Fidelity Class D (HD) amplifier". This new generation reference amplifier offers outstanding performance (high output of 700 W simultaneous) with high sound quality and reproduces the latest in multi-channel digital contents.

- **Easy setup using Advanced MCACC**

The Auto MCACC Setup provides a quick but accurate surround sound setup, which includes the advanced features of Professional Acoustic Calibration EQ. This innovative technology measures the reverberant characteristics of your listening area, allowing you to customize your system calibration with the help of a graphical output that can be displayed on-screen or using a computer. With the additional benefits of numerous MCACC preset memories, standing wave control and microphone measurements from a series of reference points, your home theater experience can be truly customized for optimal surround sound.

- **THX certified design**

This receiver bears the THX Select2 Plus logo, which means it has passed a rigorous series of quality and performance tests covering every aspect of the product. This includes testing of pre-amplifier and power amplifier

performance and operation, and hundreds of other parameters in both the digital and analog domain, making your home theater experience as faithful as possible to what the director intended.

- **Dolby Digital and DTS decoding, including Dolby Digital EX, Dolby Pro Logic IIx, DTS 96/24, DTS-ES, Dolby Digital Plus, Dolby TrueHD, DTS-EXPRESS and DTS-HD Master Audio**

Dolby Digital and DTS decoding brings theater sound right into your home with up to six channels of surround sound, including a special LFE (Low Frequency Effects) channel for deep, realistic sound effects.

The built-in Dolby Pro Logic IIx and DTS Neo:6 decoders not only provide full surround sound decoding for Dolby Surround sources, but will also generate convincing surround sound for any stereo source.

Also, with the addition of a surround back speaker, you can take advantage of the built-in Dolby Digital EX and DTS-ES decoders for six-channel surround sound.

Furthermore, Dolby Digital Plus and Dolby TrueHD, which are designed for the next-generation high-definition media such as Blu-ray Disc and HD DVD, support up to 7.1 channels and 8 channels respectively.

DTS-EXPRESS is a low-bitrate encoding technology supporting up to 5.1 channels, with fixed data transfer rates ranging from 24 kbps to 256 kbps (this encoding is available only when signals are delivered to this receiver as primary audio).

DTS-HD Master Audio delivers audio signals to listeners without any loss of data with its high transfer rates.

- **Phase Control**

The Phase Control technology incorporated into this receiver's design provides coherent sound reproduction through the use of phase matching for an optimal sound image at your listening position.

- **Full Band Phase Control**

The Full Band Phase Control feature analyzes the frequency-phase characteristics of the speakers connected and corrects the phase distortion to the flattened frequency-phase characteristics. This correction minimizes the group delay of the middle- and low-frequency ranges against the high-frequency range and improves the frequency-phase characteristics across all ranges. Furthermore, the enhanced frequency-phase characteristics between channels ensure better surround sound integration.

- **Sound Retriever**

The Sound Retriever feature employs DSP technology to restore sound pressure and smooth jagged artifacts left over after compression. This helps bring CD quality sound back to WMA and MP3 audio files and achieves a richer sense of presence when playing Dolby Digital, DTS or WMA 9 Pro audio formats recorded in multiple channels on DVDs and other discs.

- **HOME MEDIA GALLERY**

This receiver can play back contents stored on your computer when your computer is connected to the LAN terminal of this receiver. Also, you can listen to the Internet radio stations.

- **Front Stage Surround Advance**

With the Front Stage Surround Advance feature, you can enjoy seamless, natural surround sound effects using only the front speakers, without deteriorating the quality of the original sound.

- **Auto Level Control**

When the source is played in Auto level control mode (ALC), this receiver automatically equalizes the playback sound level according to the variation in recording levels.

- **Optimum Surround**

All movie creators do their best to express movie's story and use sounds 50 % to achieve it. They assume that the finally mixed sounds should be best sound balance at movie theaters that can perform a big sound. However, in many cases, such a big sound is actually too much for customer's Home Theater environment, smaller volume is normally used. In such case, there is possibility that the sound balance is changed/depressed compared to movie theaters. The volume is smaller, the possibility is higher. In short, smaller volume can NOT tell us stories properly as the same as creator's intention.

"Optimum Surround" is a new Pioneer's surround sound technology that has been newly developed to solve this problem. Throughout this development, Pioneer has been struggling to consider how we should provide creator's intention properly with home theater's sound. And Pioneer has found an answer = "Optimum Surround" led by two activities as follows. One of them is to know creator's thought and feelings to communicate with actual creators, and another is to invent some new sound tuning technologies based on Pioneer's historical technologies.

- **HDMI and digital video conversion**

This receiver is compatible with the HDMI digital video format, providing you with high-definition digital video/ audio via a single cable.

High-quality sound formats such as DTS-HD and Dolby TrueHD are supported while this receiver is also compatible with the Deep Color and x.v.Color feature. You can operate this receiver in synchronization with your Pioneer component that supports the KURO LINK function by connecting your component to this receiver

via HDMI. Also, the built-in digital video converter of this receiver makes both de-interlacing and up-scaling possible, and analog video signals being input are converted and output as digital video signals at the HDMI terminal.

- **XM and SIRIUS Ready**

With the XM and SIRIUS Radio terminals, you'll be up and running in no time. This receiver's enhanced compatibility makes XM HD Surround playback as well as on-screen control of your XM and SIRIUS Radio an added possibility.

- **iPod/iPhone and USB Ready**

This receiver has the terminals for connecting an iPod/iPhone unit and a USB mass storage device.

The iPod terminal is ready for handling digital audio and video, and this receiver's enhanced compatibility makes on-screen control of your iPod an added possibility.

The USB terminal allows you to listen to two-channel audio from a USB mass storage device connected to this receiver.

Checking what's in the box

Please check that you've received the following supplied accessories:

- Setup microphone (cable: 5 m (16.4 ft.))
- Remote control unit
- Dry cell batteries x2
- AM loop antenna
- FM wire antenna
- iPod cable
- Power cord
- Warranty card
- These operating instructions

Installing the receiver

- When installing this unit, make sure to put it on a level and stable surface.

Don't install it on the following places:

- on a color TV (the screen may distort)
- near a cassette deck (or close to a device that gives off a magnetic field). This may interfere with the sound.
- in direct sunlight
- in damp or wet areas
- in extremely hot or cold areas
- in places where there is vibration or motion
- in places that are very dusty
- in places that have hot fumes or oils (such as a kitchen)

- Do not touch this receiver's bottom panel while the power is turned on. The bottom panel gets hot when the power is on, and touching it could cause burns.

Loading the batteries

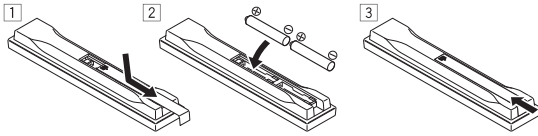

CAUTION

Incorrect use of batteries may result in such hazards as leakage and bursting. Observe the following precautions:

- Never use new and old batteries together.
- Insert the plus and minus sides of the batteries properly according to the marks in the battery case.
- Batteries with the same shape may have different voltages. Do not use different batteries together.
- When disposing of used batteries, please comply with governmental regulations or environmental public institution's rules that apply in your country or area.

WARNING

Do not use or store batteries in direct sunlight or other excessively hot place, such as inside a car or near a heater. This can cause batteries to leak, overheat, explode or catch fire. It can also reduce the life or performance of batteries.

Operating range of remote control unit

The remote control may not work properly if:

- There are obstacles between the remote control and the receiver's remote sensor.
- Direct sunlight or fluorescent light is shining onto the remote sensor.
- The receiver is located near a device that is emitting infrared rays.
- The receiver is operated simultaneously with another infrared remote control unit.

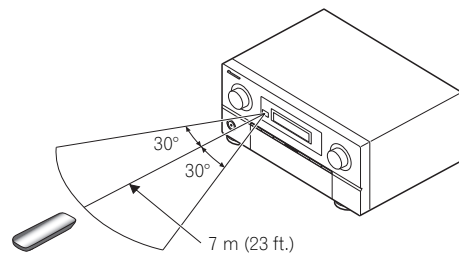

Chapter 2:

Controls and displays

Remote control

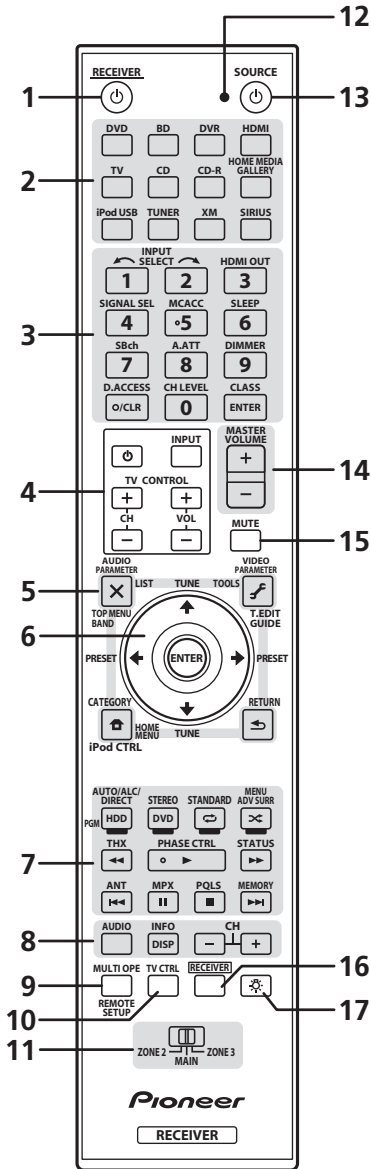

The remote has been conveniently color-coded according to component control using the following system:

- **White** – Receiver control, TV Control
- **Blue** – Other controls

1 RECEIVER

This switches between standby and on for this receiver.

2 **Input function buttons**

Press to select control of other components (see *Controlling the rest of your system* on page 89).

3 **Number buttons and other receiver/component controls**

Use the number buttons to directly select a radio frequency (page 52) or the tracks on a CD, DVD, etc.

ENTER can be used to enter commands for TV or DTV.

Press **RECEIVER** first to access:

INPUT SELECT – Use to select the input function (page 46).

HDMI OUT – Switch the HDMI output terminal (page 87).

SIGNAL SEL – Use to select an input signal (page 63).

MCACC – Press to switch between MCACC presets (page 62).

SLEEP – Use to put the receiver in sleep mode and select the amount of time before sleep (page 86).

SBch – Use to select the surround back/virtual surround back channel mode (page 61).

A.ATT – Attenuates (lowers) the level of an analog input signal to prevent distortion (page 86).

DIMMER – Dims or brightens the display (page 87).

CH LEVEL – Press repeatedly to select a channel, then use **←/→** to adjust the level (page 110).

Press **TUNER** first to access:

D.ACCESS – After pressing, you can access a radio station directly using the number buttons (page 52).

CLASS – Switches between the seven banks (classes) of radio station presets (page 52).

4 **TV CONTROL buttons**

These buttons are dedicated to control the TV assigned to the **TV** operation selector switch. Thus if you only have one TV to hook up to this system assign it to the **TV** operation selector switch (see page 92 for more on this).

– Use to turn on/off the power of the TV.

INPUT – Use to select the TV input signal.

CH +/- – Use to select channels.

VOL +/- – Use to adjust the volume on your TV.

5 Tuner/component control buttons/HOME MENU

These button controls can be accessed after you have selected the corresponding input function button (**DVD**, **DVR**, **TV**, etc.). The **BAND** and **T.EDIT** tuner controls are explained on page 52 and page 52.

Press **RECEIVER** first to access:

AUDIO PARAMETER – Use to access the Audio options (page 82).

VIDEO PARAMETER – Use to access the Video options (page 83).

HOME MENU – Use to access the Home Menu (pages 42, 44, 80, 95, 104, 106, 108 and 112).

RETURN – Press to confirm and exit the current menu screen (also use to return to the previous menu with DVDs or to select closed captioning with DTV).

6 ↑/↓/←/→ (TUNE/PRESET) /ENTER

Use the arrow buttons when setting up your surround sound system (see page 95) and the Audio or Video options (page 82 or 83). Also used to control DVD menus/options and for deck 1 of a double cassette deck player. Use **TUNE** ↑/↓ to find radio frequencies and use **PRESET** ←/→ to find preset stations (page 52).

7 Component/Receiver control buttons

The main buttons (▶, ■, etc.) are used to control a component after you have selected it using the input function buttons.

The controls above these buttons can be accessed after you have selected the corresponding input function button (for example **DVD**, **DVR** or **TV**). These buttons also function as described below.

Press **TUNER** first to access:

MPX – Switches between stereo and mono reception of FM broadcasts. If the signal is weak, then switching to mono will improve the sound quality (page 52).

NOISE CUT MODE 1 or **2** can be selected when this unit is receiving AM broadcasts.

Press **RECEIVER** first to access:

AUTO/ALC/DIRECT – Switches between Auto Surround (page 57), Auto level control, Optimum Surround mode and Stream Direct mode (page 60).

STEREO – Switches between stereo playback and Front Stage Surround Advance modes (page 60).

STANDARD – Press for Standard decoding and to switch between the various **PRO LOGIC IIx** and **Neo:6** options (page 57).

ADV SURR – Use to switch between the various surround modes (page 59).

THX – Press to select a Home THX listening mode (page 58).

PHASE CTRL – Press to switch on/off Phase Control or Full Band Phase Control (page 63).

STATUS – Press to check selected receiver settings (page 87).

PQLS – Press to select PQLS setting (page 81).

8 AUDIO – Changes the audio or channel on DVD or BD discs.

DISP – Switches between named station presets and radio frequencies.

CH +/- – Use to select channels for DVD/DVR units.

9 REMOTE SETUP

Use to input the preset code when making remote control settings and to set the remote control mode (page 89).

10 TV CTRL

Use this button to set preset code of your TV's manufacturer when controlling TV (see *Selecting preset codes directly* on page 89 for more on this).

11 MULTI-ZONE operation selector switch

Switch to perform operations in the main zone, ZONE 2 and ZONE 3 (page 85).

12 Remote control LED

Lights when a command is sent from the remote control (page 89).

13 SOURCE

Press to turn on/off other components connected to the receiver (see page 89 for more on this).

14 MASTER VOLUME +/-

Use to set the listening volume.

15 MUTE

Mutes the sound or restores the sound if it has been muted (adjusting the volume also restores the sound).

16 RECEIVER

Switches the remote to control the receiver (used to select the white commands above the number buttons (**A.ATT**, etc.)). Also use this button to set up surround sound.

17

Press to turn on/off the illumination of some of the buttons.

Front panel

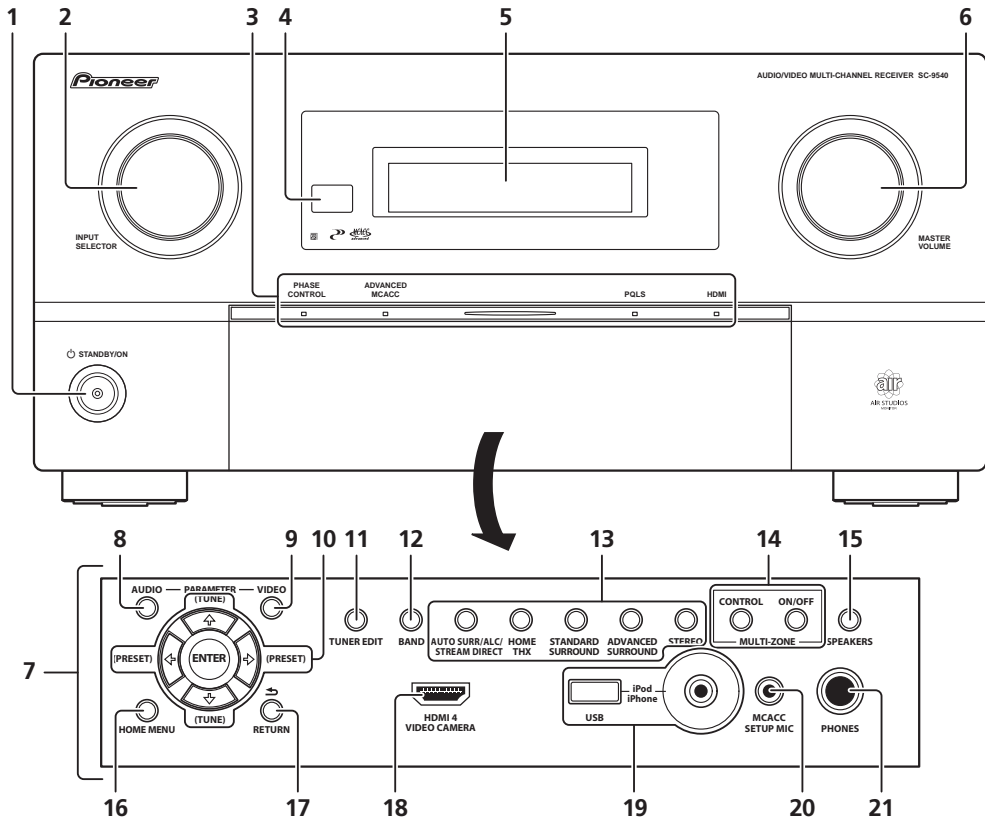

1 STANDBY/ON

Switches the receiver between on and standby. Power indicator lights when the receiver is on.

When the **KURO LINK** function is set to **ON**, the power indicator lights when the power is in standby.

2 INPUT SELECTOR dial

Use to select an input function (page 46).

3 PHASE CONTROL indicator – Lights to indicate Phase Control or Full Band Phase Control is selected (page 63).

ADVANCED MCACC indicator – Lights when **EQ** is set to **ON** in the **AUDIO PARAMETER** menu (page 82).

PQLS indicator – Lights when the PQLS feature is active (page 81).

HDMI indicator – Blinks when connecting an HDMI-equipped component; lights when the component is connected (page 26).

4 Remote sensor

Receives the signals from the remote control (see *Operating range of remote control unit* on page 11).

5 Character display

See *Display* on page 15.

6 MASTER VOLUME dial

7 Front panel controls

To access the front panel controls, push gently on the lower third portion of the panel with your finger.

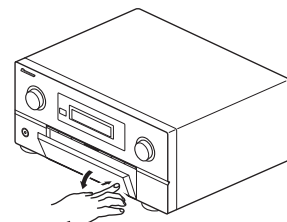

8 AUDIO PARAMETER

Use to access the Audio options (page 82).

9 VIDEO PARAMETER

Use to access the Video options (page 83).

10 ↑/↓/←/→ (TUNE/PRESET) /ENTER

Use the arrow buttons when setting up your **HOME MENU**. Use **TUNE** ↑/↓ to find radio frequencies and use **PRESET** ←/→ to find preset stations (page 52).

11 TUNER EDIT

Use with ↑/↓/←/→/ENTER to memorize and name stations for recall (page 52).

12 BAND

Switches between AM and FM radio bands (page 52).

13 Listening mode buttons

AUTO SURR/ALC/STREAM DIRECT – Switches between Auto Surround (page 57), Auto level control, Optimum Surround mode and Stream Direct mode (page 60).

HOME THX – Press to select a Home THX listening mode (page 58).

STANDARD SURROUND – Press for Standard decoding and to switch between the various **DD** Pro Logic IIx and Neo:6 options (page 57).

ADVANCED SURROUND – Use to switch between the various surround modes (page 59).

STEREO – Switches between stereo playback and Front Stage Surround Advance modes (page 60).

14 MULTI-ZONE controls

If you've made MULTI-ZONE connections (see *MULTI-ZONE setup* on page 35) use these controls to control the sub zone from the main zone (see *Using the MULTI-ZONE controls* on page 85).

15 SPEAKERS

Use to change the speaker system (page 84).

16 HOME MENU

Press to access the Home Menu (pages 42, 44, 80, 95, 104, 106, 108 and 112).

17 RETURN

Press to confirm and exit the current menu screen.

18 HDMI input connector

Use for connection to compatible HDMI device (Video camera, etc.). See *Connecting an HDMI-equipped component to the front panel input* on page 39.

19 iPod/iPhone/USB terminals

Use to connect your Apple iPod as an audio and video source, or connect a USB device for audio and photo playback (page 40).

20 MCACC SETUP MIC jack

Use to connect the supplied microphone (page 42).

21 PHONES jack

Use to connect headphones. When the headphones are connected, there is no sound output from the speakers.

Display

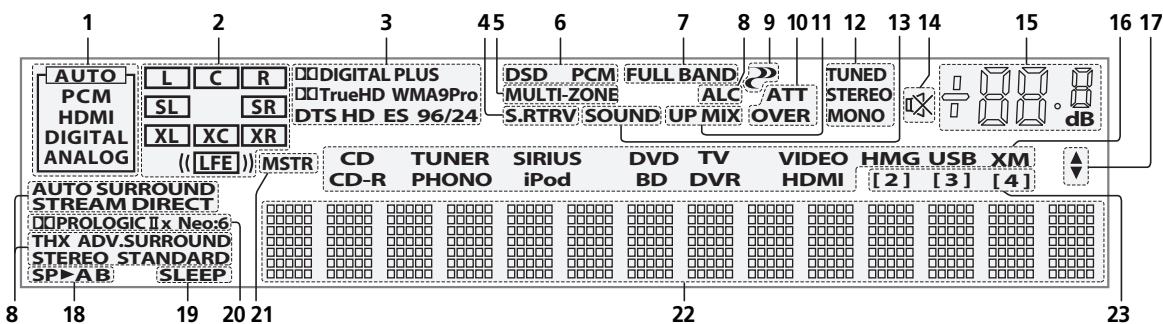

1 SIGNAL indicators

Light to indicate the currently selected input signal. **AUTO** lights when the receiver is set to select the input signal automatically (page 63).

2 Program format indicators

Light to indicate the channels being input when PCM signals are being input. They do not indicate the audio signals being output from the receiver.

- L/R – Left front/Right front channel
- C – Center channel
- SL/SR – Left surround/Right surround channel

LFE – Low frequency effects channel (the (()) indicators light when an LFE signal is being input)

XL/XR – Two channels other than the ones above

XC – Either one channel other than the ones above, the mono surround channel or matrix encode flag

3 Digital format indicators

Light when a signal encoded in the corresponding format is detected.

4 S.RTRV

Lights when the Sound Retriever function is active (page 82).

5 MULTI-ZONE

Lights when the MULTI-ZONE feature is active (page 85).

6 DSD PCM – Light during DSD (Direct Stream Digital) to PCM conversion with SACDs.

PCM – Lights during playback of PCM signals.

7 FULL BAND

Lights when the Full Band Phase Control is switched on (page 64).

8 Listening mode indicators

AUTO SURROUND – Lights when the Auto Surround feature is switched on (page 57).

ALC – Lights when the ALC (Auto level control) mode is selected (page 60).

STREAM DIRECT – Lights when Direct/Pure Direct is selected (page 60).

ADV.SURROUND – Lights when one of the Advanced Surround modes has been selected (page 59).

STEREO – Lights when stereo listening is switched on (page 59).

STANDARD – Lights when one of the Standard Surround modes is switched on (page 57).

THX – Lights when one of the Home THX modes is selected (page 58).

9  (PHASE CONTROL)

Lights when the Phase Control or Full Band Phase Control is switched on (page 63).

10 Analog signal indicators

Light to indicate reducing the level of an analog signal (page 86).

11 UP MIX

Lights when the Up Mix is switched on (page 62).

12 Tuner indicators

TUNED – Lights when a broadcast is being received.

STEREO – Lights when a stereo FM broadcast is being received in auto stereo mode.

MONO – Lights when the mono mode is set using **MPX**.

13 SOUND

Lights when any of the Midnight, Loudness or tone controls feature is selected (page 82).

Lights when Dialog Enhancement is switched on.

14 

Lights when the sound is muted (page 13).

15 Master volume level

Shows the overall volume level.

"---" indicates the minimum level, and "+12dB" indicates the maximum level.

16 Input function indicators

Light to indicate the input function you have selected.

17 Scroll indicators

Light when there are more selectable items when making the various settings.



18 Speaker indicators

Lights to indicate the current speaker system, **A** and/or **B** (page 84).

19 SLEEP

Lights when the receiver is in sleep mode (page 86).

20 Matrix decoding format indicators

 **PRO LOGIC IIx** – This lights to indicate  Pro Logic II /  Pro Logic IIx decoding (page 57).

Neo:6 – When one of the Neo:6 modes of the receiver is on, this lights to indicate Neo:6 processing (page 57).

21 MSTR

Lights during playback of DTS-HD Master Audio signal.

22 Character display

Displays various system information.

23 Remote control mode indicator

Lights to indicate the receiver's remote control mode setting. (Not displayed when set to **1**.)

Chapter 3:

Connecting your equipment

This receiver provides you with many connection possibilities, but it doesn't have to be difficult. This page explains the kinds of components you can connect to make up your home theater system.

Rear panel

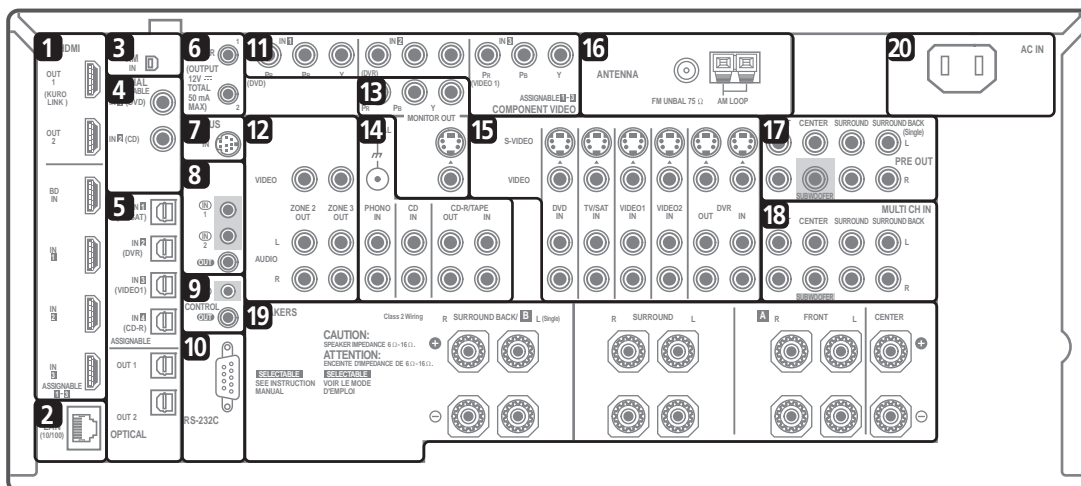

CAUTION

- Before making or changing the connections, switch off the power and disconnect the power cord from the power outlet. Plugging in should be the final step.
- To avoid hum, do not lay connected cables over the top of the receiver.

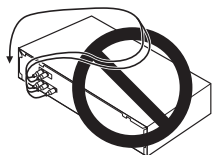

1 HDMI connectors (x6)

Multiple inputs and two outputs for high-quality audio/video connection to compatible HDMI devices.
 → See *Connecting your TV and playback components* on page 26.
 → See *Switching the HDMI output* on page 87.

2 LAN (10/100) terminal

→ See *Playback with HOME MEDIA GALLERY inputs* on page 66.

3 XM Radio input

→ See *Connecting an XM Radio tuner* on page 34.

4 Coaxial digital audio inputs (x2)

Use for digital audio sources, including DVD players/recorders, digital satellite receivers, CD players, etc.
 → See also *The Input Setup menu* on page 44 to assign the inputs.

5 Optical digital audio inputs (x4)/outputs (x2)

Use the **OUT** jack for recording to a CD or MiniDisc recorder.
 → See *Connecting other audio components* on page 32.
 Use the **IN** jacks for digital audio sources, including DVD players/recorders, digital satellite receivers, CD players, etc.
 → See also *The Input Setup menu* on page 44 to assign the inputs.

6 12 V trigger jacks (total 50 mA max.) (x2)

Use to switch components in your system on and off according to the input function of the receiver.
 → See *Switching components on and off using the 12 volt trigger* on page 38.

7 SIRIUS Radio input

→ See *Connecting a SiriusConnect™ tuner* on page 34.

8 Remote inputs/output

Use for connection to an external remote control sensor for use in a MULTI-ZONE setup, for example.
 → See *Connecting an IR receiver* on page 37.

9 Control input/output

Use to connect other Pioneer components so that you can control all your equipment from a single IR remote sensor.

→ See *Operating other Pioneer components with this unit's sensor* on page 37.

10 RS-232C connector

Use for connection to a PC for graphical output when using Advanced MCACC or Full Band Phase Control.

→ See *Connecting a PC for Advanced MCACC output* on page 38.

11 Component video inputs (x3)

Use the inputs to connect any video source that has component video output, such as a DVD player.

→ See *Connecting your DVD player with no HDMI output* on page 27.

12 MULTI-ZONE audio/video outputs

Use to connect a second or third amplifier and monitors or TVs in a separate room.

→ See *MULTI-ZONE setup* on page 35.

13 Composite, S-Video and Component video monitor outputs

Use to connect monitors and TVs.

→ See *Connecting your TV with no HDMI input* on page 28.

14 Stereo analog audio source inputs (x3)/output (x1)

Use for connection to audio sources such as CD players, tape decks, turntables, etc.

→ See *Connecting other audio components* on page 32.

15 Audio/video source inputs (x5)/output (x1)

Use for connection to audio/visual sources, such as DVD players/recorders, VCRs, etc. Each set of inputs has jacks for composite video, S-Video and stereo analog audio.

→ See *Connecting an HDD/DVD recorder, VCR and other video sources* on page 30.

16 AM and FM antenna terminals

Use to connect indoor or outdoor antennas for radio broadcasts.

→ See *Connecting AM/FM antennas* on page 33.

17 Multichannel pre-amplifier outputs

Use to connect separate amplifiers for front, center, surround, surround back and subwoofer channels.

→ See *Connecting additional amplifiers* on page 33 (see also *Installing your speaker system* on page 22 for powered subwoofer connection).

18 Multichannel analog audio inputs

7.1 channel inputs for connection to a DVD player with multichannel analog outputs.

→ See *Connecting the multichannel analog inputs* on page 31.

19 Speaker terminals

Use for connection to the main front, center, surround and surround back speakers.

→ See *Connecting the speakers* on page 21.

20 AC power inlet

Connect the supplied power cord here.

→ See *Plugging in the receiver* on page 41.

Determining the speakers' application

Surround sound with a strong sense of presence can be enjoyed by connecting 7 speakers and 1 subwoofer. It is also possible to achieve high sound quality using bi-amp connections and to enjoy music in other rooms using the MULTI-ZONE feature. High sound quality can be achieved with a minimum of two speakers.

- Be sure to connect speakers to the front left and right channels (**L** and **R**).
- The **Surr Back System** setting must be made if you use any of the connections shown below other than [1] (see *Selecting the Surr Back system* on page 24).

[1] 7.1ch surround connection (Simple connection & Best surround)

*Default setting

These connections prioritize surround sound with a speaker layout like that in a movie theater.

- **Surr Back System setting: Normal** (default)
- If you have six speakers, either only connect one surround back speaker (6.1 ch surround), or connect for the 7.1-channel setting as shown on the diagram below but without the center speaker.

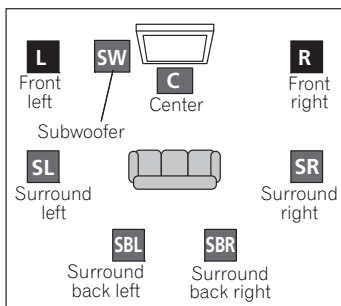

[2] 5.1ch surround & Front Bi-amping connection (High quality surround)

Bi-amping connection of the front speakers for high sound quality with 5.1-channel surround sound.

- **Surr Back System setting: Front Bi-Amp**

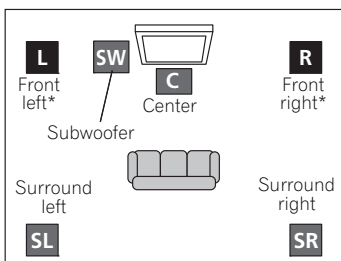

*Bi-amp compatible speaker

[3] 5.1ch surround & ZONE 2 connection (Multi Zone)

With these connections you can simultaneously enjoy 5.1-channel surround sound in the main zone with stereo playback on another component in ZONE 2. (The selection of input devices is limited.)

- **Surr Back System setting: ZONE 2**

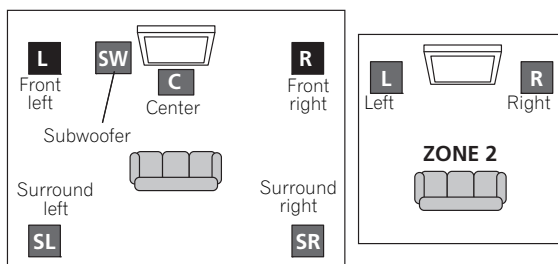

[4] 5.1ch surround & Speaker B connection

With these connections you can simultaneously enjoy 5.1-channel surround sound in the main zone with stereo playback of the same sound on the B speakers.

- **Surr Back System setting: Speaker B**

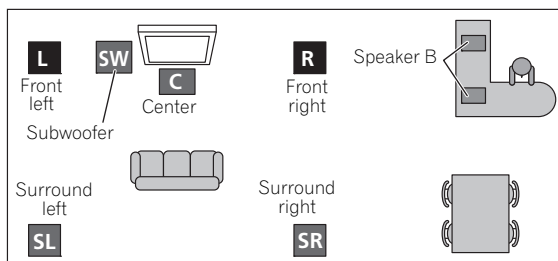

Other speaker connection

- Your favorite speaker connections can be selected even if you have fewer than 5.1 speakers.
- When not connecting a subwoofer, connect speakers with low frequency reproduction capabilities to the front channel. (The subwoofer's low frequency component is played from the front speakers, so the speakers could be damaged.)
- **After connecting, be sure to conduct the Auto MCACC (speaker environment setting) procedure.** See *Automatically setting up for surround sound (Auto MCACC & Full Band Phase Control)* on page 42.

Placing the speakers

To achieve the best possible surround sound, install your speakers as shown below.

5.1 channel surround system:

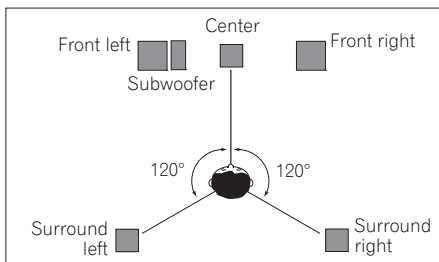

6.1 channel surround system:

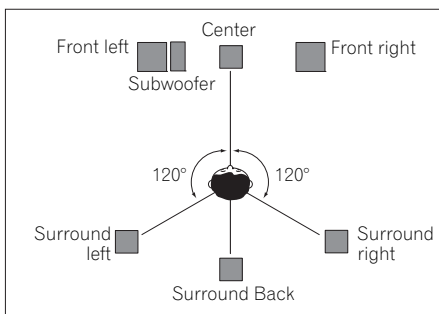

7.1 channel surround system:

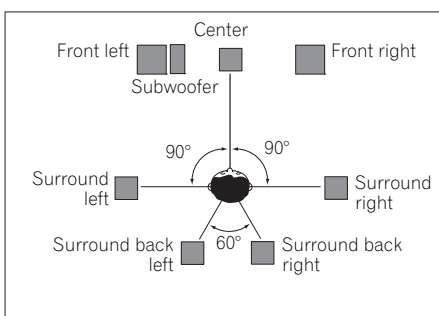

THX speaker system setup

If you are using a THX certified subwoofer use the **THX INPUT** jack on the subwoofer (if your subwoofer has one) or switch the filter position to **THX** on your subwoofer.

See also *THX Audio Setting* on page 111 to make the settings that will give you the best sound experience when using the Home THX modes (page 58).

Some tips for improving sound quality

Where you put your speakers in the room has a big effect on the quality of the sound. The following guidelines should help you to get the best sound from your system.

- The subwoofer can be placed on the floor. Ideally, the other speakers should be at about ear-level when you're listening to them. Putting the speakers on the floor (except the subwoofer), or mounting them very high on a wall is not recommended.
- For the best stereo effect, place the front speakers 2 m to 3 m (6 ft. to 9 ft.) apart, at equal distance from the TV.
- If you're using a center speaker, place the front speakers at a wider angle. If not, place them at a narrower angle.
- Place the center speaker above or below the TV so that the sound of the center channel is localized at the TV screen. Also, make sure the center speaker does not cross the line formed by the leading edge of the front left and right speakers.
- It is best to angle the speakers towards the listening position. The angle depends on the size of the room. Use less of an angle for bigger rooms.
- Surround and surround back speakers should be positioned 60 cm to 90 cm (2 ft. to 3 ft.) higher than your ears and tilted slight downward. Make sure the speakers don't face each other. For DVD-Audio, the speakers should be more directly behind the listener than for home theater playback.
- If the surround speakers cannot be set directly to the side of the listening position with a 7.1-channel system, the surround effect can be enhanced by turning off the Up Mix function (see *Setting the Up Mix function* on page 62).
- Try not to place the surround speakers farther away from the listening position than the front and center speakers. Doing so can weaken the surround sound effect.

Connecting the speakers

Each speaker connection on the receiver comprises a positive (+) and negative (-) terminal. Make sure to match these up with the terminals on the speakers themselves.

⚠ CAUTION

- These speaker terminals carry **HAZARDOUS LIVE voltage**. To prevent the risk of electric shock when connecting or disconnecting the speaker cables, disconnect the power cord before touching any uninsulated parts.
- Make sure that all the bare speaker wire is twisted together and inserted fully into the speaker terminal. If any of the bare speaker wire touches the back panel it may cause the power to cut off as a safety measure.

Bare wire connections

- 1 **Twist exposed wire strands together.** (fig. A)
- 2 **Loosen terminal and insert exposed wire.** (fig. B)
- 3 **Tighten terminal.** (fig. C)

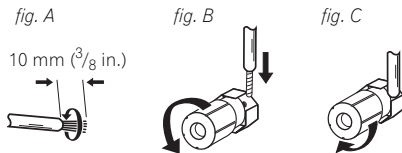

Banana plug connections

If you want to use speaker cables terminated with banana plugs, screw the speaker terminal fully shut, then plug the banana plug into the end of the speaker terminal.

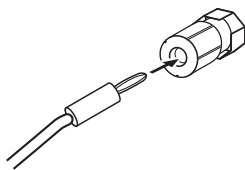

👉 Important

- Please refer to the manual that came with your speakers for details on how to connect the other end of the speaker cables to your speakers.
- Use an RCA cable to connect the subwoofer. It is not possible to connect using speaker cables.

⚠ CAUTION

- Make sure that all speakers are securely installed. This not only improves sound quality, but also reduces the risk of damage or injury resulting from speakers being knocked over or falling in the event of external shocks such as earthquakes.

Installing your speaker system

At the very least, front left and right speakers only are necessary. Note that your main surround speakers should always be connected as a pair, but you can connect just one surround back speaker if you like (it must be connected to the left surround back terminal).

Standard 5.1/6.1/7.1-channel surround connections

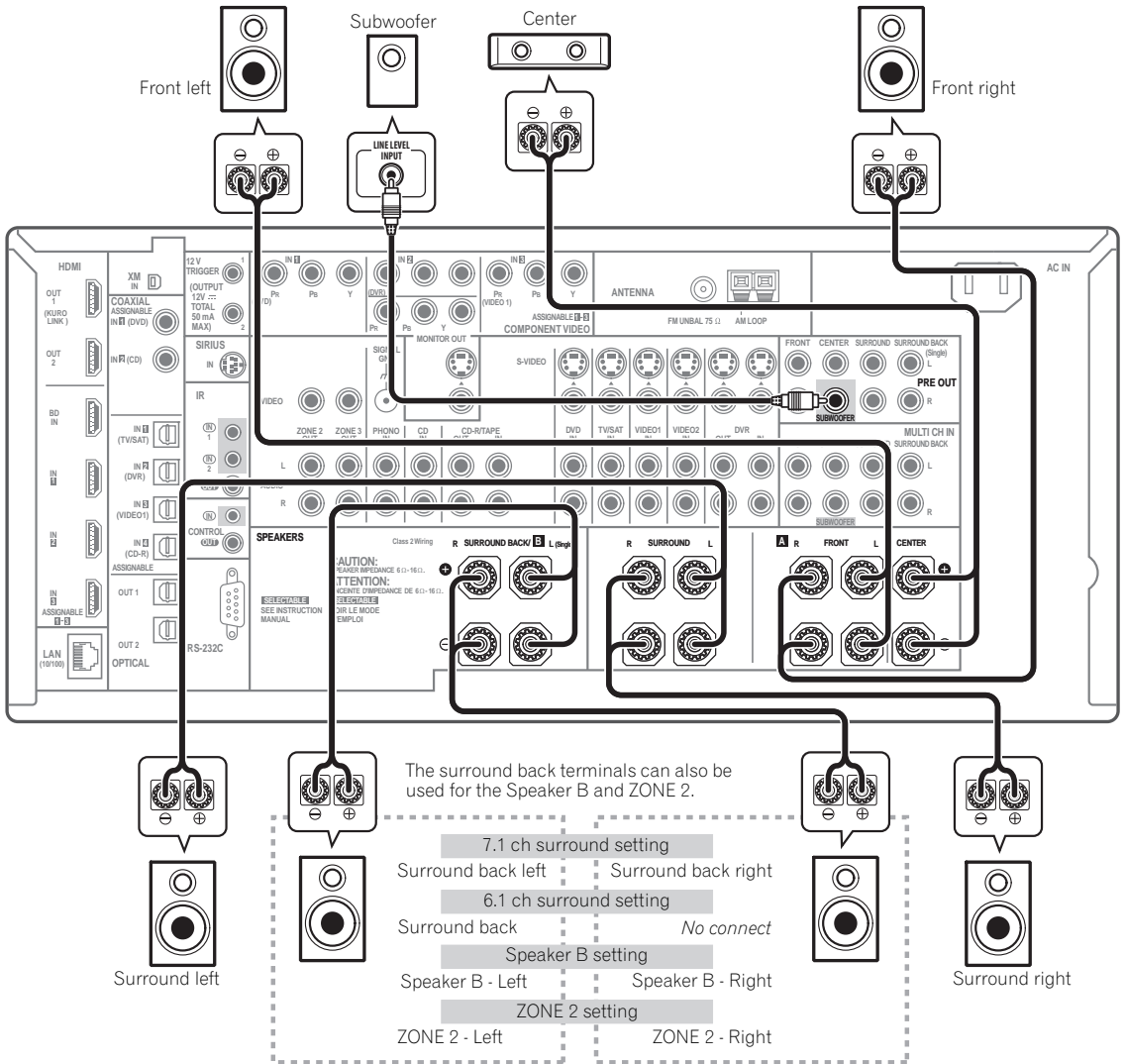

Bi-amping your speakers

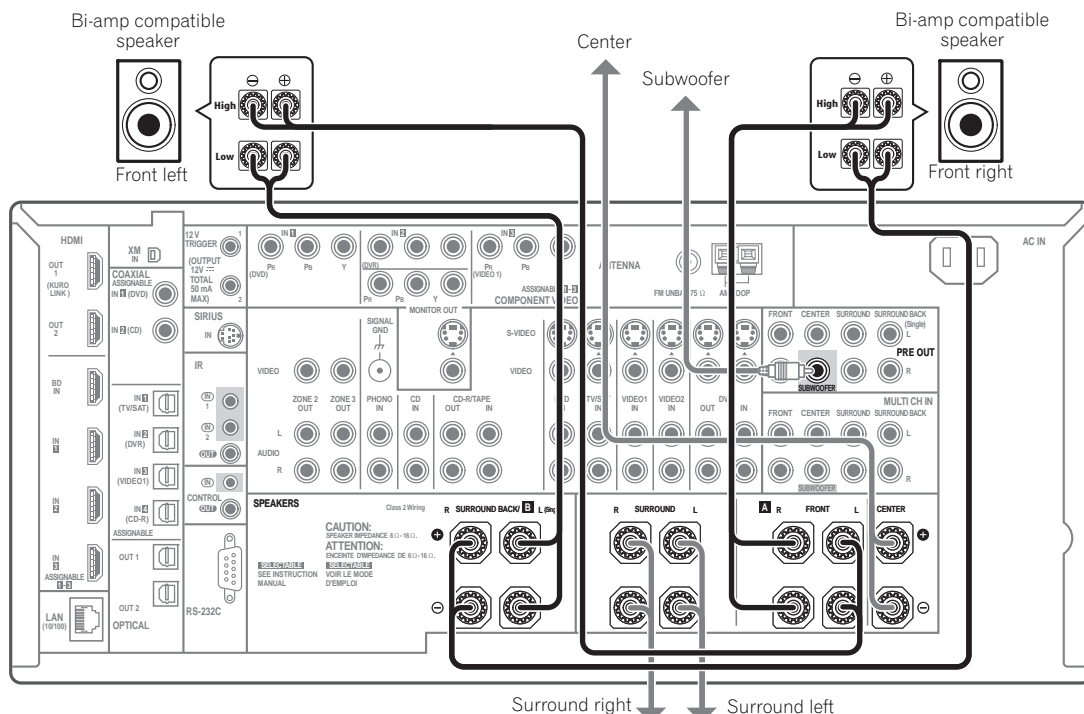

Bi-amping is when you connect the high frequency driver and low frequency driver of your speakers to different amplifiers for better crossover performance. Your speakers must be bi-ampable to do this (having separate terminals for high and low) and the sound improvement will depend on the kind of speakers you're using.

CAUTION

- Most speakers with both **High** and **Low** terminals have two metal plates that connect the **High** to the **Low** terminals. These must be removed when you are bi-amping the speakers or you could severely damage the amplifier. See your speaker manual for more information.
- If your speakers have a removable crossover network, make sure you do not remove it for bi-amping. Doing so may damage your speakers.

Bi-wiring your speakers

Your speakers can also be bi-wired if they support bi-amping.

- With these connections, the **Surr Back System** setting makes no difference.
- **To bi-wire a speaker, connect two speaker cords to the speaker terminal on the receiver.** Using a banana plug for the second connection is recommended.

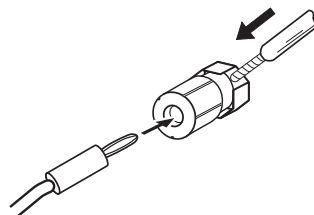

CAUTION

- Don't connect different speakers from the same terminal in this way.
- When bi-wiring as well, heed the cautions for bi-amping shown at the left.

Selecting the Surr Back system

The surround back terminals can be used for bi-amping, Speaker B and ZONE 2 connections, in addition to for the surround back speakers. Make this setting according to the application.

ZONE 2 setup

With these connections you can simultaneously enjoy 5.1-channel surround sound in the main zone with stereo playback on another component in ZONE 2.

1 Connect a pair of speakers to the surround back speaker terminals.

See *Standard 5.1/6.1/7.1-channel surround connections* on page 22.

2 Select 'ZONE 2' from the Surr Back System menu.

See *Surround back speaker setting* on page 109 to do this.

Speaker B setup

You can listen to stereo playback in another room.

1 Connect a pair of speakers to the surround back speaker terminals.

See *Standard 5.1/6.1/7.1-channel surround connections* on page 22.

2 Select 'Speaker B' from the Surr Back System menu.

See *Surround back speaker setting* on page 109 to do this.

Bi-Amping setup

Bi-amping connection of the front speakers for high sound quality with 5.1-channel surround sound.

1 Connect Bi-amp compatible speakers to the front and surround back speaker terminals.



See *Bi-amping your speakers* on page 23.

2 Select 'Front Bi-Amp' from the Surr Back System menu.

See *Surround back speaker setting* on page 109 to do this.

About the audio connection

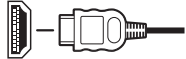
There are several types of audio input and output terminals on this receiver. The receiver selects the first available signal in the following order when you choose **AUTO** as the input signal:

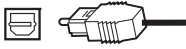
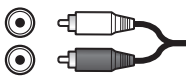
	Types of cables and terminals	Transferable audio signals
↑ Sound signal priority	HDMI 	HD audio
	Digital (Coaxial)  Digital (Optical) 	Conventional digital audio
	RCA (Analog) (White/Red) 	Conventional analog audio

- With an HDMI cable, video and audio signals can be transferred in high quality over a single cable.

⚠ CAUTION

- When connecting optical cables, be careful when inserting the plug not to damage the shutter protecting the optical socket.
- When storing optical cable, coil loosely. The cable may be damaged if bent around sharp corners.

About the video converter

The video converter ensures that all video sources are output through all of the **MONITOR OUT** jacks. The only exception is HDMI: since this resolution cannot be downsampled, you must connect your monitor/TV to the receiver's HDMI video outputs when connecting this video source.¹

If several video components are assigned to the same input function (see *The Input Setup menu* on page 44), the converter gives priority to HDMI, component, S-Video, then composite (in that order).

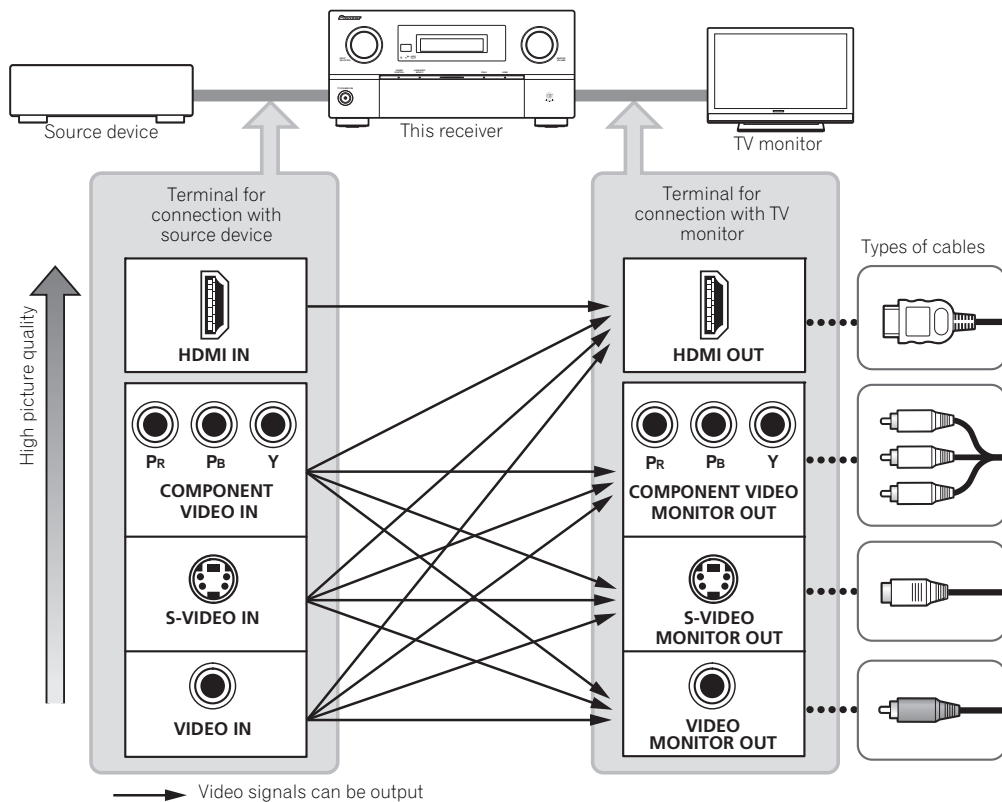

- For optimal video performance, THX recommends switching Digital Video Conversion (in *Setting the Video options* on page 83) **OFF**.

This product incorporates copyright protection technology that is protected by method claims of certain U.S. patents and other intellectual property rights owned by Macrovision Corporation and other rights owners. Use of this copyright protection technology must be authorized by Macrovision Corporation, and is intended for home and other limited viewing uses only unless otherwise authorized by Macrovision Corporation. Reverse engineering or disassembly is prohibited.

Note

- 1 • If the video signal does not appear on your TV or flat panel TV, try adjusting the resolution settings on your component or display. Note that some components (such as video game units) have resolutions that may not be converted. In this case, try switching Digital Video Conversion (in *Setting the Video options* on page 83) **OFF**.
 - The signal input resolutions that can be converted from the component video input for the HDMI output are 480i/576i, 480p/576p, 720p and 1080i. 1080p signal cannot be converted.
 - Only signals with an input resolution of 480i/576i can be converted from the component video input for the composite and S-Video **MONITOR OUT**.

Connecting your TV and playback components

Connecting using HDMI

If you have an HDMI or DVI (with HDCP) equipped component (Blu-ray disc player, etc.), you can connect it to this receiver using a commercially available HDMI cable.

If the TV and playback components support the Pioneer KURO LINK feature, the convenient KURO LINK functions can be used (see *KURO LINK* on page 79).

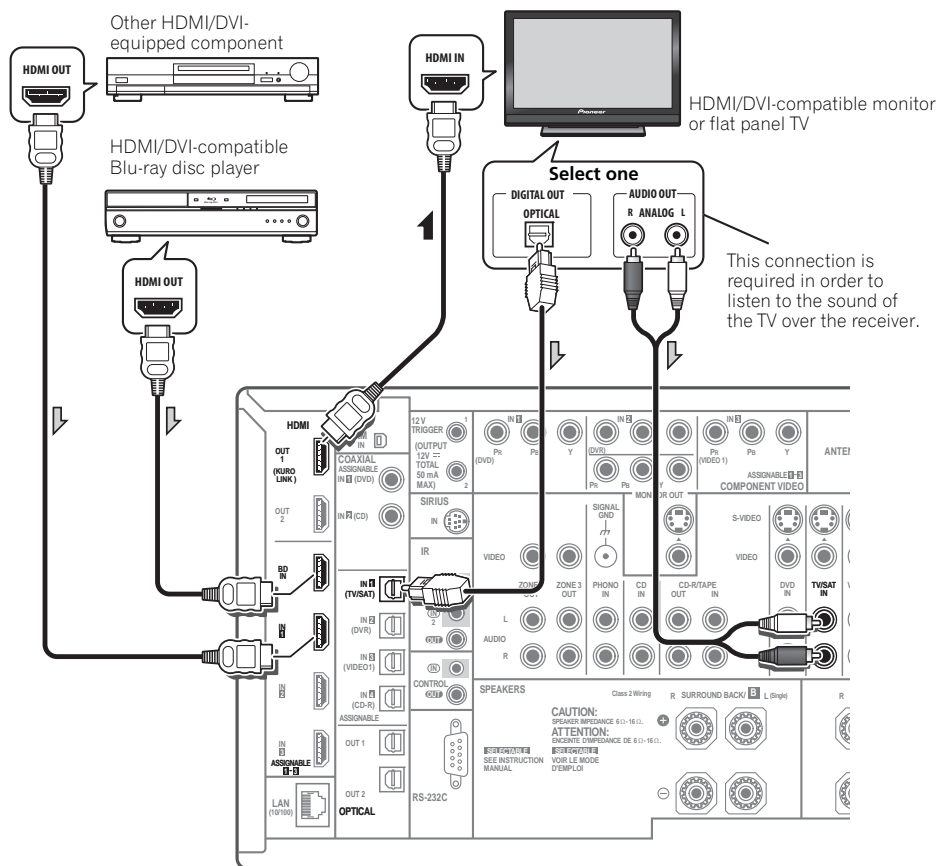

- When connecting a Blu-ray disc player, connect the player to the receiver's **BD IN** terminal.
- When connecting to an HDMI/DVI-compatible monitor or a flat panel TV using the **HDMI OUT 2** terminal, switch the HDMI output setting to **HDMI OUT 2** or **HDMI OUT ALL**. See *Switching the HDMI output* on page 87.
- The **HDMI** indicator lights on the front panel when an HDMI-equipped component is connected.
- For input components, connections other than HDMI connections are also possible (see *Connecting your DVD player with no HDMI output* on page 27).
- If your Blu-ray disc player offers multi-channel analog audio outputs, see *Connecting the multichannel analog inputs* on page 31.
- The sound of the TV cannot be heard over the receiver if the TV is connected using an HDMI cable. If you want to listen to the sound of the TV over the receiver, connect the receiver and TV with audio cables.

Connecting your DVD player with no HDMI output

This diagram shows connections of a TV (with HDMI input) and DVD player (or other playback component with no HDMI output) to the receiver.

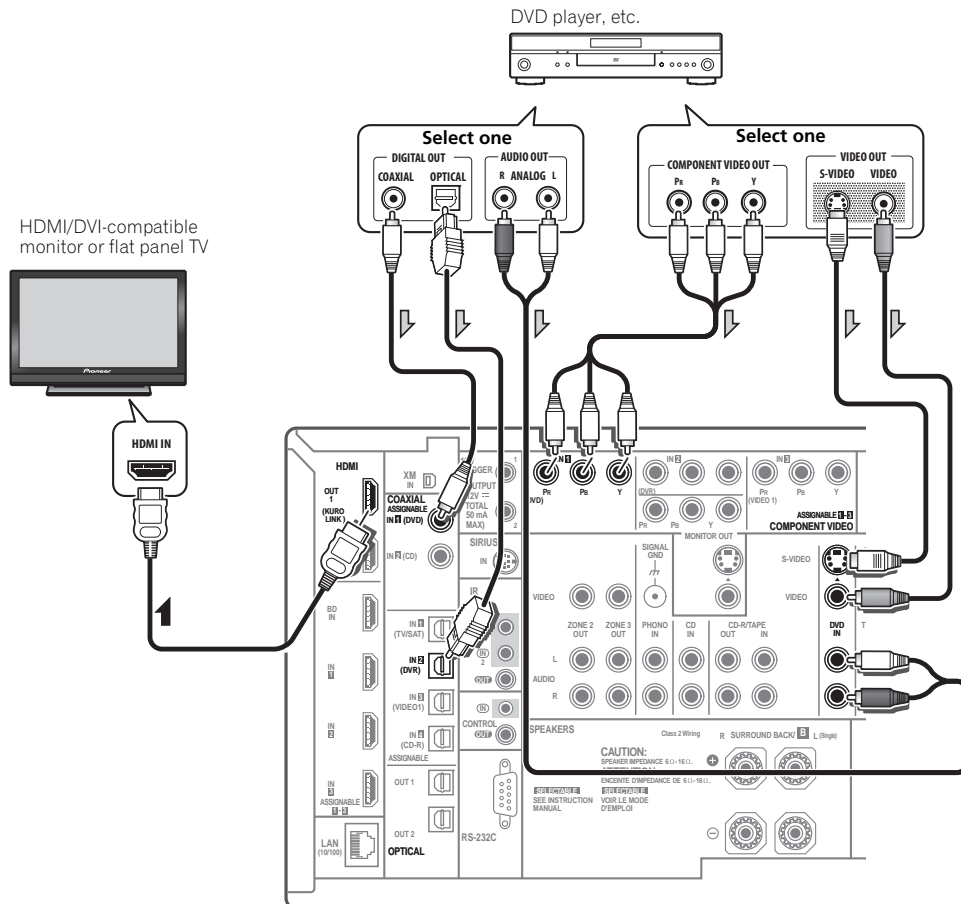

- If you want to listen to the sound of the TV over the receiver, connect the receiver and TV with audio cables.
- Component video should give superior picture quality when compared to composite or S-Video. You can also take advantage of progressive scan video (if your source and TV are both compatible), which delivers a very stable, flicker-free picture. See the manuals that came with your TV and source component to check whether they are compatible with progressive-scan video.
- If your DVD player offers multi-channel analog audio outputs, see *Connecting the multichannel analog inputs* on page 31.

Connecting your TV with no HDMI input

This diagram shows connections of a TV (with no HDMI input) and DVD player (or other playback component) to the receiver.

- With these connections, the picture is not output to the TV even if the DVD player is connected with an HDMI cable. Connect the DVD player's video signals using a composite, S-VIDEO or component cord.

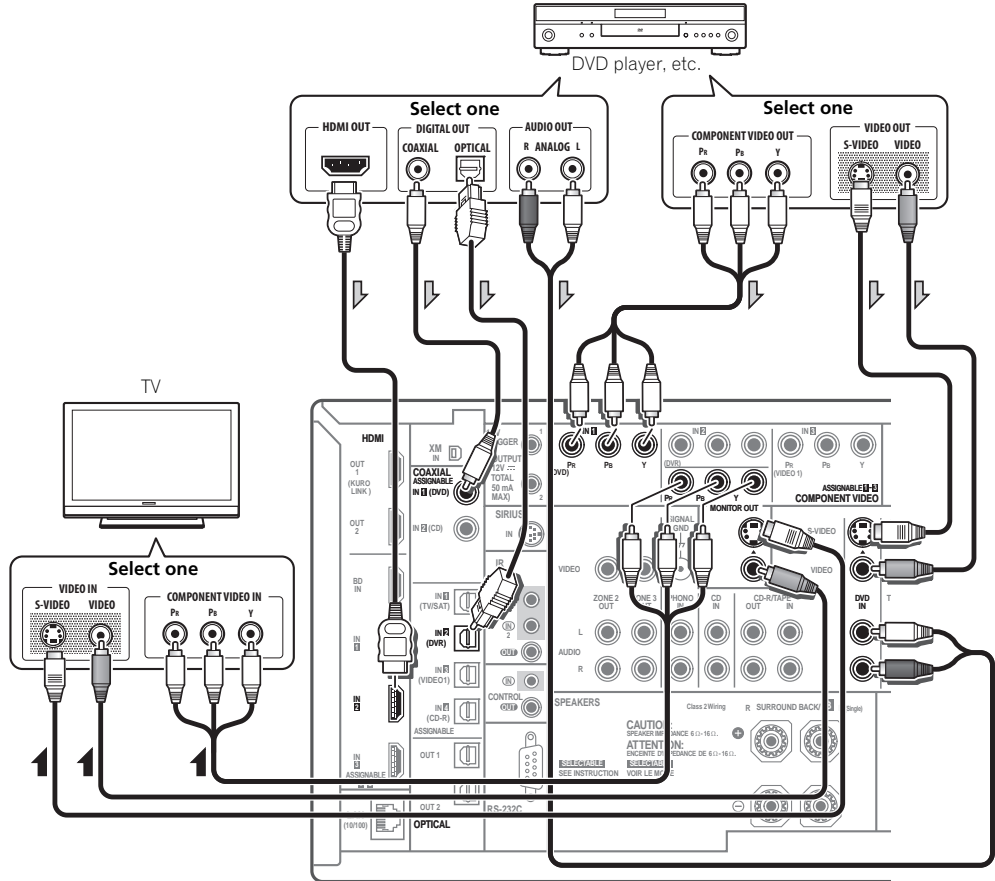

- Connect using an HDMI cable to listen to HD audio on the receiver. Do not use an HDMI cable to input video signals. Depending on the video component, it may not be possible to output signals connected by HDMI and other methods simultaneously, and it may be necessary to make output settings. Please refer to the operating instructions supplied with your component for more information.
- Component video should give superior picture quality when compared to composite or S-Video. You can also take advantage of progressive scan video (if your source and TV are both compatible), which delivers a very stable, flicker-free picture. See the manuals that came with your TV and source component to check whether they are compatible with progressive-scan video.
- If your DVD player has multichannel analog outputs, you can connect these instead. See also see *Connecting the multichannel analog inputs* on page 31.

- The input functions below are assigned by default to the receiver's different input terminals. Refer to *The Input Setup menu* on page 44 to change the assignments if other connections are used. For example, the BD terminal is fixed to **BD** input; no other audio and video signals can be input to this terminal.

Input function	Input Terminals		
	Digital	HDMI	Component
DVD	COAX-1		IN 1
BD		(BD)	
TV/SAT	OPT-1		
DVR	OPT-2		IN 2
VIDEO 1	OPT-3		IN 3
VIDEO 2			
HDMI 1		(HDMI-1)	
HDMI 2		(HDMI-2)	
HDMI 3		(HDMI-3)	
HDMI 4 (front panel)		(HDMI-4)	
CD	COAX-2		
CD-R/TAPE	OPT-4		

About HDMI¹

The HDMI connection transfers uncompressed digital video, as well as almost every kind of digital audio that the connected component is compatible with, including DVD-Video, DVD-Audio, SACD, Dolby Digital Plus, Dolby TrueHD, DTS-HD Master Audio (see below for limitations), Video CD/Super VCD and CD. See *About the video converter* on page 25 for more on HDMI compatibility.

This receiver incorporates High-Definition Multimedia Interface (HDMI™) technology.

This receiver supports the functions described below through HDMI connections.

- Digital transfer of uncompressed video (contents protected by HDCP (1080p/24, 1080p/60, etc.))
- Deep Color signal transfer²
- x.v.Color signal transfer²
- Input of multi-channel linear PCM digital audio signals (192 kHz or less) for up to 8 channels
- Input of the following digital audio formats:
 - Dolby Digital, Dolby Digital Plus, DTS, High bitrate audio (Dolby TrueHD, DTS-HD Master Audio), DVD-Audio, CD, SACD (DSD signal), Video CD, Super VCD
- Synchronized operation with components using the KURO LINK function (see *KURO LINK* on page 79)

HDMI, the HDMI logo and High-Definition Multimedia Interface are trademarks or registered trademarks of HDMI Licensing, LLC.

"x.v.Color" and x.v.Color logo are trademarks of Sony Corporation.

Note

- An HDMI connection can only be made with DVI-equipped components compatible with both DVI and High Bandwidth Digital Content Protection (HDCP). If you choose to connect to a DVI connector, you will need a separate adaptor (DVI→HDMI) to do so. A DVI connection, however, does not support audio signals. Consult your local audio dealer for more information.
 - If you connect a component that is not compatible with HDCP, an **HDCP ERROR** message is displayed on the front panel display. Some components that are compatible with HDCP still cause this message to be displayed, but so long as there is no problem with displaying video this is not a malfunction.
 - Depending on the component you have connected, using a DVI connection may result in unreliable signal transfers.
 - This receiver supports SACD, Dolby Digital Plus, Dolby TrueHD and DTS-HD Master Audio. To take advantage of these formats, however, make sure that the component connected to this receiver also supports the corresponding format.
- Signal transfer is only possible when connected to a compatible component.

Connecting an HDD/DVD recorder, VCR and other video sources

This receiver has two sets of audio/video inputs and outputs suitable for connecting analog or digital video devices, including HDD/DVD recorders and VCRs.

When you set up the receiver you'll need to tell the receiver which input you connected the recorder to (see also *The Input Setup menu* on page 44).

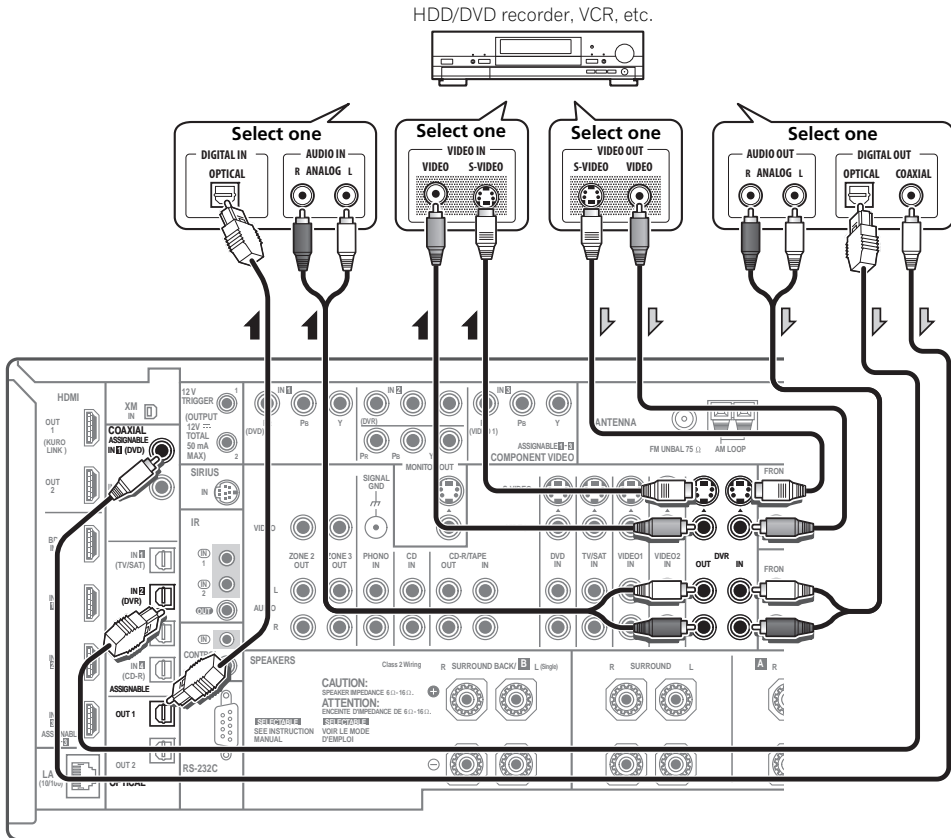

Connecting a satellite/cable receiver or other set-top box

Satellite and cable receivers, and terrestrial digital TV tuners are all examples of so-called 'set-top boxes'.

When you set up the receiver you'll need to tell the receiver which input you connected the set-top box to (see *The Input Setup menu* on page 44).

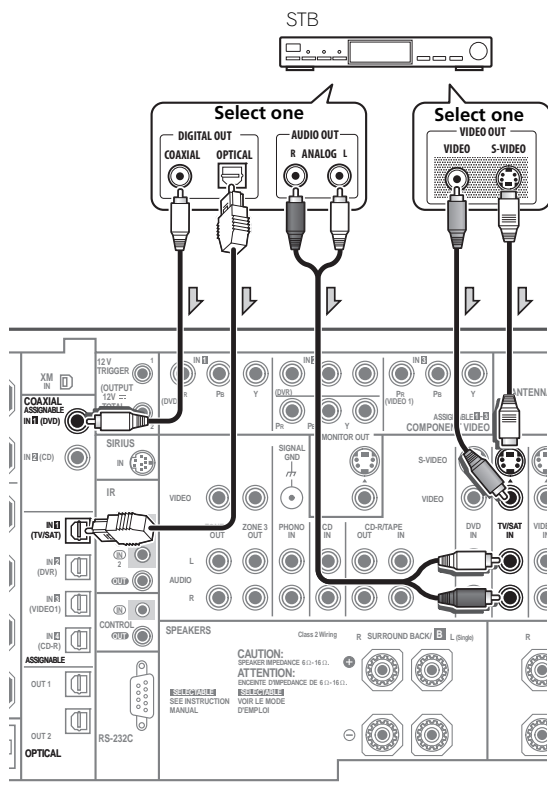

Connecting the multichannel analog inputs

For DVD Audio and SACD playback, your DVD player may have 5.1, 6.1 or 7.1 channel analog outputs (depending on whether your player supports surround back channels). Make sure that the player is set to output multichannel analog audio.

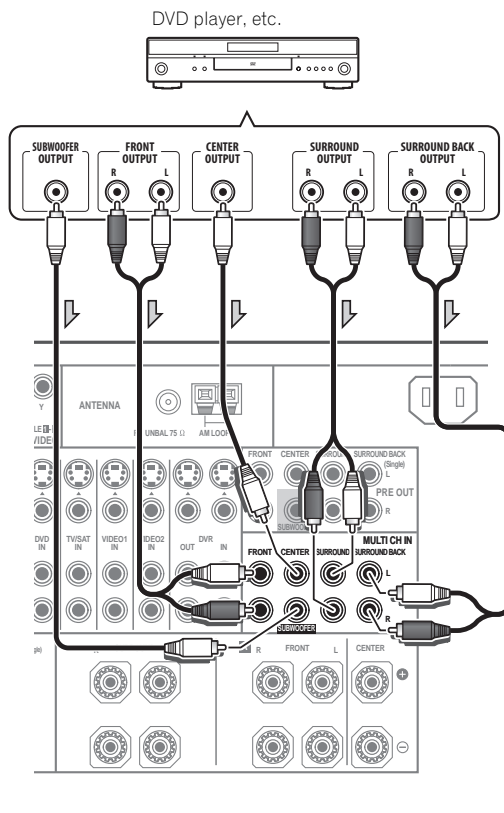

- If there is a single surround back output, connect it to the **SURROUND BACK L** jack on this receiver.
- To use a 5.1-channel speaker set, use the surround speakers for the surround channel, not the surround back channel.

Connecting other audio components

This receiver has both digital and analog inputs, allowing you to connect audio components for playback.

This receiver features five stereo audio-only inputs. One of these inputs have corresponding outputs for use with audio recorders.

One of the audio inputs (**PHONO**) is a dedicated turntable input which should not be used for any other type of component. This input also has a grounding terminal that most turntables require.

Most digital components also have analog connections.

When you set up the receiver you'll need to tell the receiver which input you connected the component to (see also *The Input Setup menu* on page 44).

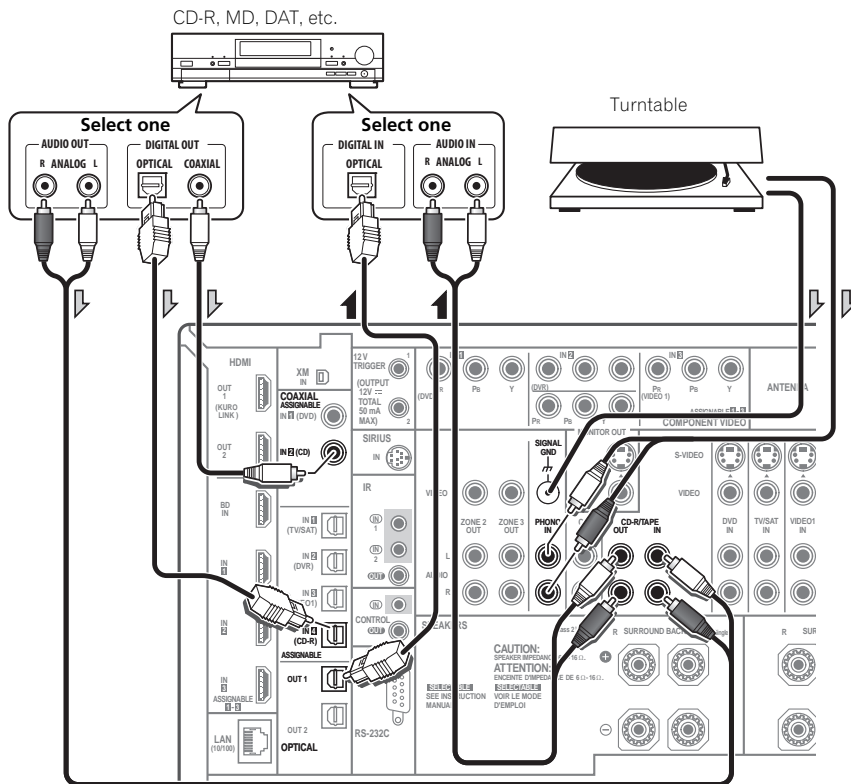

- If you're connecting a recorder, connect the analog audio outputs to the analog audio inputs on the recorder.

Turntables only:

- If your turntable has a grounding wire, secure it to the ground terminal on this receiver.
- If your turntable has line-level outputs (i.e., it has a built-in phono pre-amp), connect it to the **CD** inputs instead.

About the WMA9 Pro decoder

This unit has an on-board Windows Media™ Audio 9 Professional¹ (WMA9 Pro) decoder, so it is possible to playback WMA9 Pro-encoded audio using HDMI, coaxial or optical digital connection when connected to a WMA9 Pro-compatible player. However, the connected DVD player, set-top box, etc. must be able to output WMA9 Pro format audio signals through a coaxial or optical digital output.

Note

¹ • Windows Media and the Windows logo are trademarks or registered trademarks of Microsoft Corporation in the United States and/or other countries.

• With WMA9 Pro, sound problems may occur depending on your computer system. Note that WMA9 Pro 96 kHz sources will be downsampled to 48 kHz.

Connecting additional amplifiers

This receiver has more than enough power for any home use, but it's possible to add additional amplifiers to every channel of your system using the pre-outs. Make the connections shown below to add amplifiers to power your speakers.

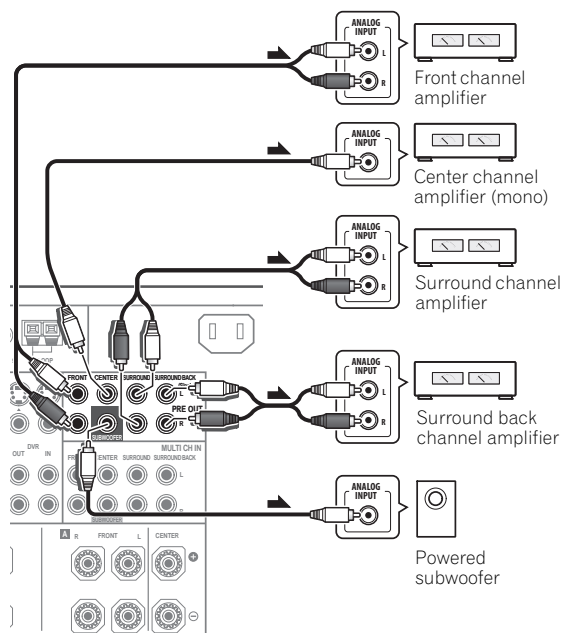

- You can use the additional amplifier on the surround back channel pre-outs for a single speaker as well. In this case plug the amplifier into the left (L (Single)) terminal only.
- The sound from the surround back terminals will depend on how you have configured the *Surround back speaker setting* on page 109.
- To hear sound only from the pre-outs, switch the speaker system to **OFF**, or simply disconnect any speakers that are connected directly to the receiver.

If you're not using a subwoofer, change the front speaker setting (see *Speaker Setting* on page 109) to **LARGE**.

Connecting AM/FM antennas

Connect the AM loop antenna and the FM wire antenna as shown below. To improve reception and sound quality, connect external antennas (see *Connecting external antennas* below).

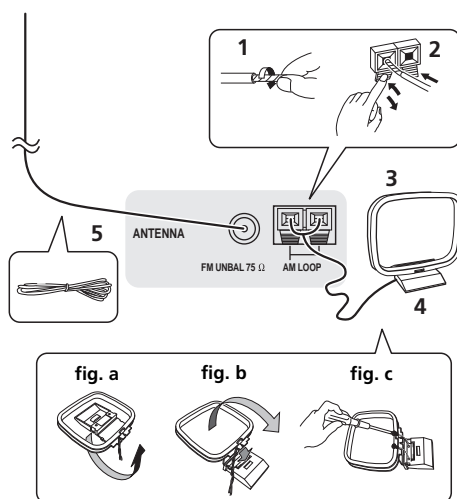

1 Pull off the protective shields of both AM antenna wires.

2 Push open the tabs, then insert one wire fully into each terminal, then release the tabs to secure the AM antenna wires.

3 Fix the AM loop antenna to the attached stand.
To fix the stand to the antenna, bend in the direction indicated by the arrow (*fig. a*) then clip the loop onto the stand (*fig. b*).

- If you plan to mount the AM antenna to a wall or other surface, secure the stand with screws (*fig. c*) before clipping the loop to the stand. Make sure the reception is clear.

4 Place the AM antenna on a flat surface and in a direction giving the best reception.

5 Connect the FM wire antenna in the same way as the AM loop antenna.

For best results, extend the FM antenna fully and fix to a wall or door frame. Don't drape loosely or leave coiled up.

Connecting external antennas

To improve FM reception connect an external FM antenna to the **FM UNBAL 75 Ω**.

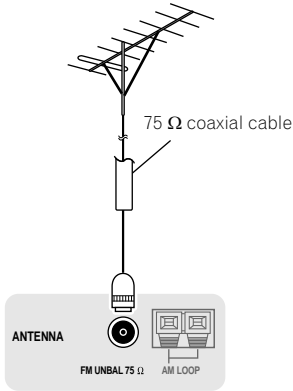

To improve AM reception, connect a 5 m to 6 m (16 ft. to 20 ft.) length of vinyl-coated wire to the **AM LOOP** terminals without disconnecting the supplied AM loop antenna.

For the best possible reception, suspend horizontally outdoors.

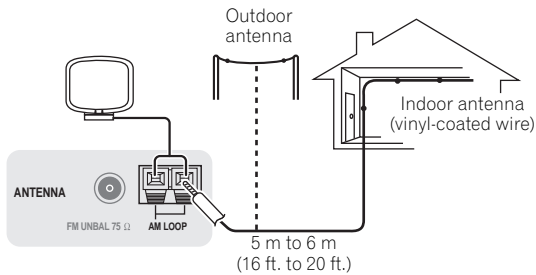

Connecting an XM Radio tuner

After purchasing an XM Mini-Tuner and Home Dock (both sold separately), you will also need to activate the XM Radio service to begin receiving broadcasts.

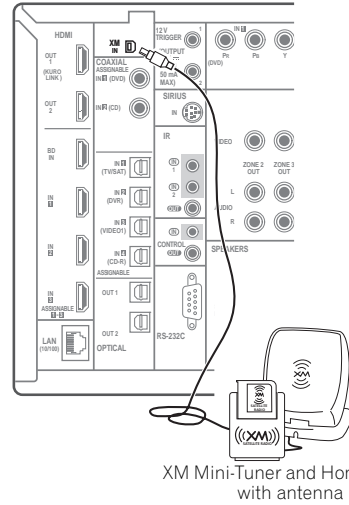

- For instructions on playing the XM Radio, see *Listening to XM Radio* on page 53.

Connecting a SiriusConnect™ tuner

To receive SIRIUS Satellite Radio broadcasts, you will need to activate your SiriusConnect™ tuner.

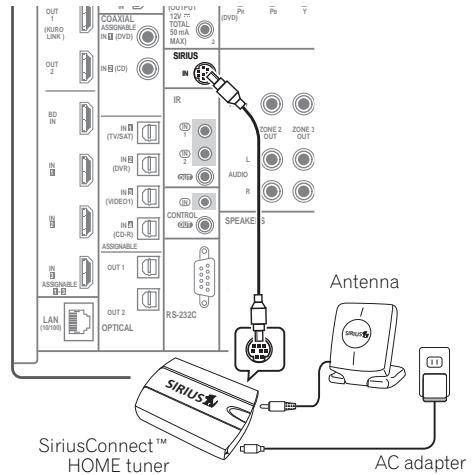

You will also need to connect the antenna and AC adapter to the SiriusConnect™ tuner.

- For instructions on playing the SIRIUS Radio, see *Listening to SIRIUS Radio* on page 55.

MULTI-ZONE setup

This receiver can power up to three independent systems in separate rooms after you have made the proper MULTI-ZONE connections. An example MULTI-ZONE setup is shown below, but the number of MULTI-ZONE connections (and the way you choose to connect them) depends on how you want to set up your system.

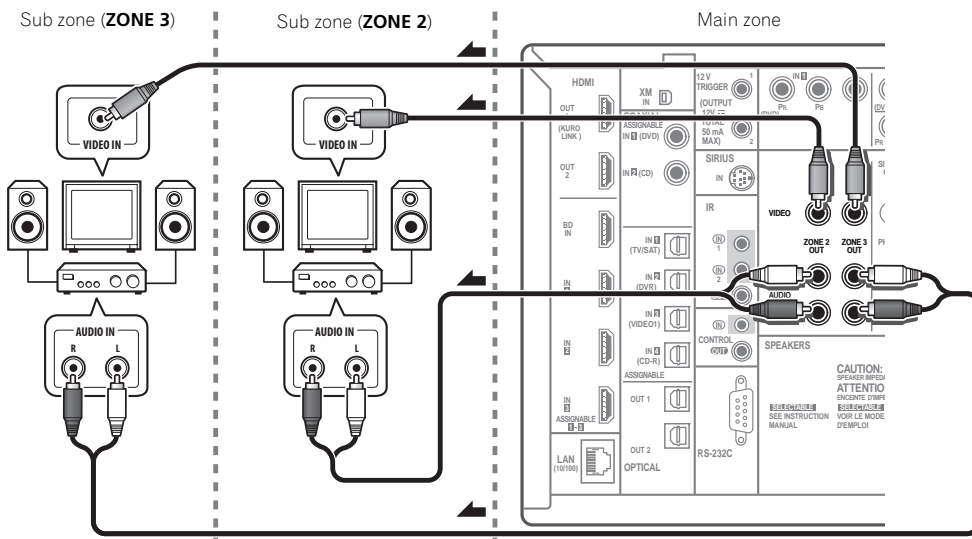

Different sources can be playing in three zones at the same time or, depending on your needs, the same source can also be used. The main and sub zones have independent power (the main zone power can be off while one (or both) of the sub zones is on) and the sub zones can be controlled by the remote or front panel controls. However, you may need to specify the volume settings in *ZONE Audio Setup* on page 113.

Making MULTI-ZONE connections

It is possible to make these connections if you have a separate TV and speakers for your primary (ZONE 2) sub zone, and a separate TV and a separate amplifier¹ (and speakers) for your secondary (ZONE 3) sub zone. You will also need a separate amplifier if you are not using the *MULTI-ZONE setup using speaker terminals (ZONE 2)* on page 36 for your primary sub zone. There are two primary sub zone setups possible with this system. Choose whichever works best for you.

MULTI-ZONE listening options

The following table shows the signals that can be output to ZONE 2 and ZONE 3:

Sub Zone	Input functions available
ZONE 2	Analog audio signals (AUDIO ZONE 2 OUT). ^a With video signals, ^b the composite video (VIDEO ZONE 2 OUT) signals can be output.
ZONE 3	Analog audio signals (AUDIO ZONE 3 OUT). ^a With video signals, ^b the composite video (VIDEO ZONE 3 OUT) signals can be output.

a. Any analog signal. (This does not apply for the MULTI CH IN and PHONO inputs.)

b. JPEG files cannot be played with the input set to USB input.

Note

¹ You can't use sound controls (such as the tone controls or Midnight listening) or any surround modes with a separate amplifier in the sub zone. You can, however, use the features available with your sub zone amplifier.

Basic MULTI-ZONE setup (ZONE 2)

- Connect a separate amplifier to the **AUDIO ZONE 2 OUT** jacks and a TV monitor to the **VIDEO ZONE 2 OUT** jack, both on this receiver.

You should have a pair of speakers attached to the sub zone amplifier as shown below.

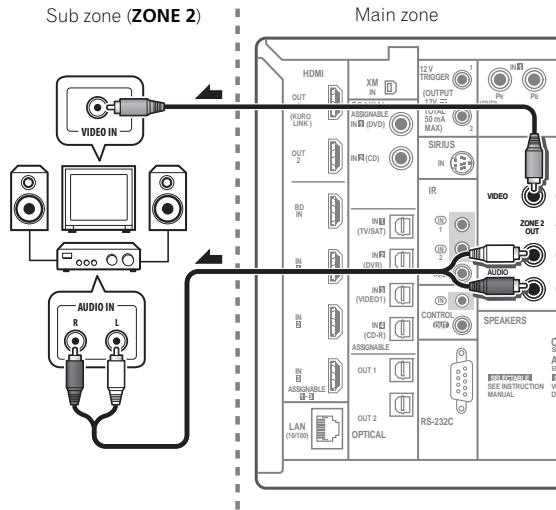

MULTI-ZONE setup using speaker terminals (ZONE 2)

You must select **ZONE 2** in *Surround back speaker setting* on page 109 to use this setup. Note that the sound in the sub zone will be temporarily interrupted when controlling the main zone (for example, changing the input function or starting playback).

- Connect a TV monitor to the **VIDEO ZONE 2 OUT** jacks on this receiver.

You should have a pair of speakers attached to the surround back speaker terminals as shown below.

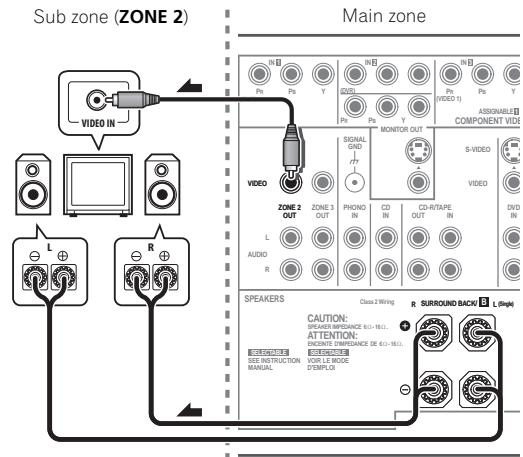

Secondary MULTI-ZONE setup (ZONE 3)

- Connect a separate amplifier to the **AUDIO ZONE 3 OUT** jacks and a TV monitor to the **VIDEO ZONE 3 OUT** jack, both on this receiver.

You should have a pair of speakers attached to the sub zone amplifier as shown below.

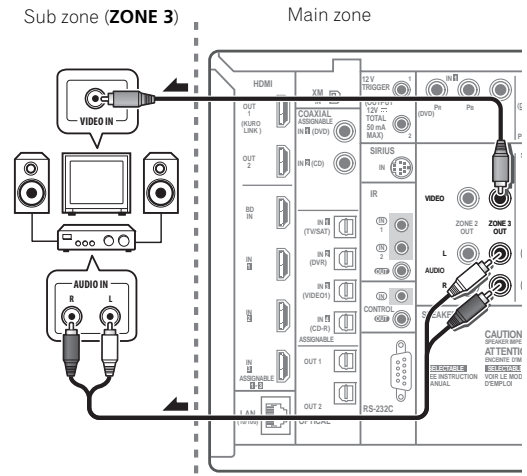

Connecting an IR receiver

If you keep your stereo components in a closed cabinet or shelving unit, or you wish to use the sub zone remote control in another zone, you can use an optional IR receiver (such as a Niles or Xantech unit) to control your system instead of the remote sensor on the front panel of this receiver.¹

1 Connect the IR receiver sensor to the IR IN jack on the rear of this receiver.

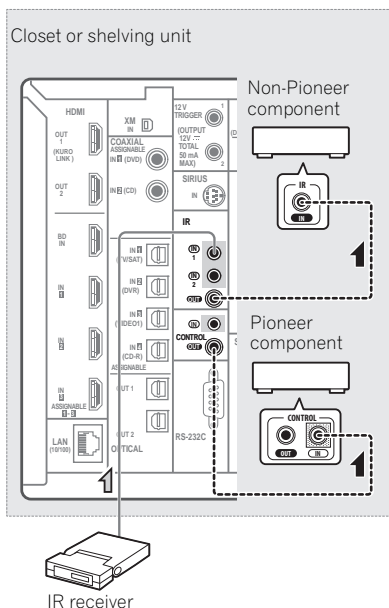

2 Connect the IR IN jack of another component to the IR OUT jack on the rear of this receiver to link it to the IR receiver.

Please see the manual supplied with your IR receiver for the type of cable necessary for the connection.

- If you want to link a Pioneer component to the IR receiver, see *Operating other Pioneer components with this unit's sensor* below to connect to the **CONTROL** jacks instead of the **IR OUT** jack.

Operating other Pioneer components with this unit's sensor

Many Pioneer components have **SR CONTROL** jacks which can be used to link components together so that you can use just the remote sensor of one component. When you use a remote control, the control signal is passed along the chain to the appropriate component.²

Important

- Note that if you use this feature, *make sure that you also have at least one set of analog audio, video or HDMI jacks connected to another component for grounding purposes.*

1 Decide which component you want to use the remote sensor of.

When you want to control any component in the chain, this is the remote sensor at which you'll point the corresponding remote control.

2 Connect the CONTROL OUT jack of that component to the CONTROL IN jack of another Pioneer component.

Use a cable with a mono mini-plug on each end for the connection.

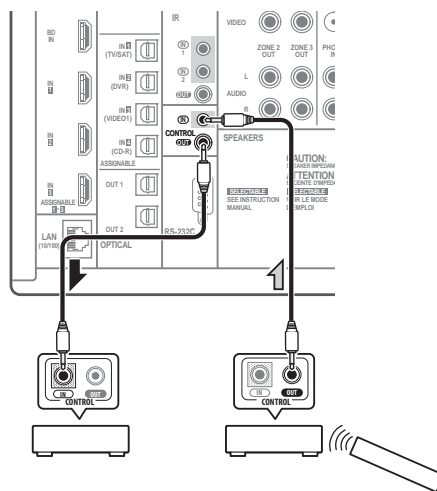

Continue the chain in the same way for as many components as you have.

Note

- Remote operation may not be possible if direct light from a strong fluorescent lamp is shining on the IR receiver remote sensor window.
 - Note that other manufacturers may not use the IR terminology. Refer to the manual that came with your component to check for IR compatibility.
 - If using two remote controls (at the same time), the IR receiver's remote sensor takes priority over the remote sensor on the front panel.
- If you want to control all your components using this receiver's remote control, see *Setting the remote to control other components* on page 89.
 - If you have connected a remote control to the **CONTROL IN** jack (using a mini-plug cable), you won't be able to control this unit using the remote sensor.

Switching components on and off using the 12 volt trigger

You can connect components in your system (such as a screen or projector) to this receiver so that they switch on or off using 12 volt triggers when you select an input function. However, you must specify which input functions switch on the trigger using the *The Input Setup menu* on page 44. Note that this will only work with components that have a standby mode.¹

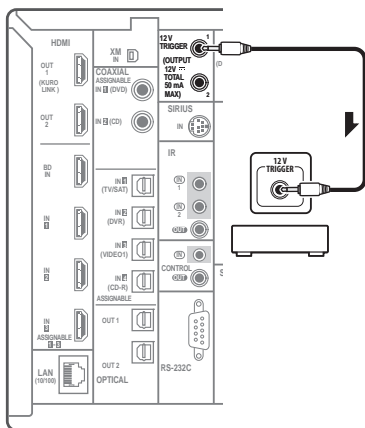

- **Connect the 12 V TRIGGER jack of this receiver to the 12 V trigger of another component.**

Use a cable with a mono mini-plug on each end for the connection.

- The trigger maximum power is DC OUT 12 V/50 mA.

After you've specified the input functions that will switch on the trigger, you'll be able to switch the component on or off just by pressing the input function(s) you've set on page 44.

Connecting a PC for Advanced MCACC output

When using the Acoustic Calibration EQ Professional (see page 101) to calibrate the reverb characteristics of your listening room, the 3D graphs of the reverb characteristics and group delay characteristics in your listening room (before and after calibration) can be checked on a computer screen by connecting the receiver to the computer and using a special application to transfer the data. The various MCACC parameters can also be checked on the computer.

Use a commercially-available RS-232C cable to connect the RS-232C jack on your computer to the 9-pin RS-232C jack on the back panel of this receiver (the cable must be cross type, female–female).

The software to output the results is available from the support area of the Pioneer website (<http://www.pioneerelectronics.com/PUSA/Home+Entertainment+Custom+Install>). Instructions for using the software are also available here. If you have any questions regarding, please contact the Customer Support Division of Pioneer.

Please make sure your system meets the following requirements:

- The computer must be a PC functioning with one of the following operating systems: Microsoft® Windows® Vista Home Basic/Home Premium/Ultimate SP1, Windows® XP Professional/Home Edition SP3 or Windows® 2000 Professional SP4.
- The monitor must have a display resolution of 800 x 600 dots (SVGA) or greater.
- The computer must be equipped with at least one RS-232C port.²
- System must have internet access.

Microsoft®, Windows®Vista, Windows®XP and Windows®2000 are either registered trademarks or trademarks of Microsoft Corporation in the United States and/or other countries.

Note

¹ Triggered connections with up to two devices compatible with 12 volt triggers can be made with this receiver.

² Laptops and other computers not equipped with an RS-232C port can be connected via USB port using a commercially available USB to RS-232C converter cable (USB to serial converter cable). For instructions on COM port connections and settings, contact the manufacturer of your computer.

- **Connect your computer to the RS-232C jack on the rear panel of the receiver.**

Make sure that the receiver and all connected components are switched off and disconnected from the power outlet when you do this.¹

Use a commercially-available cable to connect the RS-232C jack on your computer to the 9-pin RS-232C jack on this receiver. See the documentation provided with the Advanced MCACC application for more information.

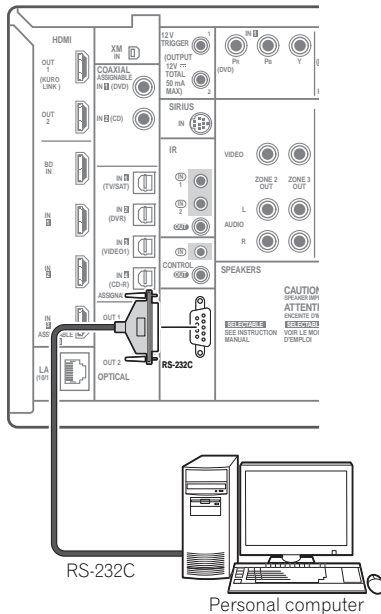

Connecting an HDMI-equipped component to the front panel input

There is an HDMI input terminal on the front panel. High quality pictures can be viewed via the receiver simply by connecting an HDMI-equipped video camera with a single HDMI cable. HDMI-equipped components other than video cameras can also be connected to this terminal.

- Push down on the lower portion of the front panel door to access the front panel input.
- Select this input using **HDMI, INPUT SELECT** (remote) or the **INPUT SELECTOR** dial (front panel) to select **HDMI 4**.

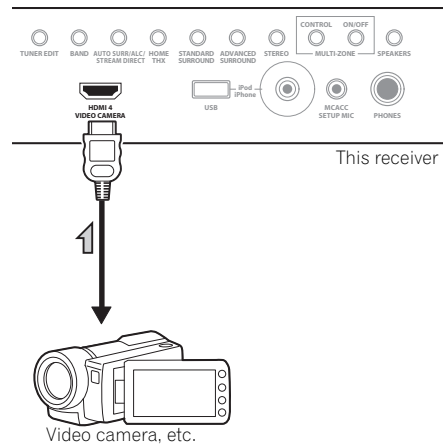

Note

¹ The various parameters, the reverb characteristics data and group delay characteristics data used for display on the computer are not cleared when the power is turned off (see *Output PC* on page 106).

Connecting an iPod

This receiver has a dedicated iPod terminal that will allow you to control playback of audio or video content from your iPod using the controls of this receiver.

- **Switch the receiver into standby then use the supplied iPod cable to connect your iPod to the iPod/iPhone/USB terminal on the front panel of this receiver.**
 - Push down on the lower portion of the front panel door to access the **iPod/iPhone/USB** terminal.
 - It is also possible to connect using the cable included with the iPod, but in this case it is not possible to view pictures via the receiver.
 - For the cable connection, refer to also the operating instructions for iPod.
 - For instructions on playing the iPod, see *Playing an iPod* on page 47.

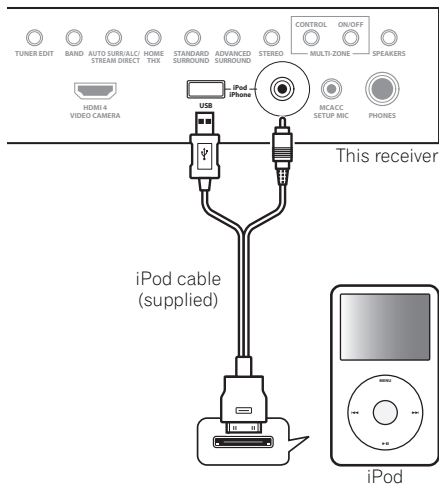

Connecting a USB device

It is possible to playback files using the USB interface on the front of this receiver.

- **Switch the receiver into standby then connect your USB device to the USB terminal on the front panel of this receiver.**
 - Push down on the lower portion of the front panel door to access the **USB** terminal.
 - For instructions on playing the USB device, see *Playing a USB device* on page 49.

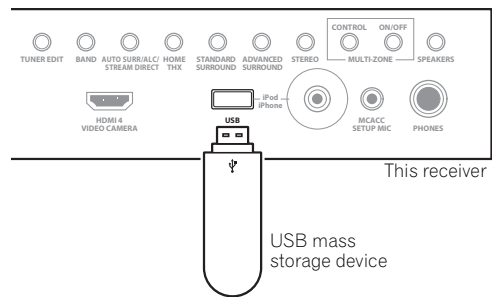

Plugging in the receiver

Only plug in after you have connected all your components to this receiver, including the speakers.

- 1 Plug the supplied power cord into the AC IN socket on the back of the receiver.
- 2 Plug the other end into a power outlet.¹

CAUTION

- Handle the power cord by the plug part. Do not pull out the plug by tugging the cord, and never touch the power cord when your hands are wet, as this could cause a short circuit or electric shock. Do not place the unit, a piece of furniture, or other object on the power cord or pinch the cord in any other way. Never make a knot in the cord or tie it with other cables. The power cords should be routed so that they are not likely to be stepped on. A damaged power cord can cause a fire or give you an electric shock. Check the power cord once in a while. If you find it damaged, ask your nearest Pioneer authorized independent service company for a replacement.
- Do not use any power cord other than the one supplied with this unit.
- Do not use the supplied power cord for any purpose other than that described below.
- The receiver should be disconnected by removing the mains plug from the wall socket when not in regular use, e.g., when on vacation.
- Make sure the blue  **STANDBY/ON** light has gone out before unplugging.

Note

¹ After this receiver is connected to an AC outlet, a 2 second to 10 second HDMI initialization process begins. You cannot carry out any operations during this process. The **HDMI** indicator in the front panel display blinks during this process, and you can turn on this receiver once it has stopped blinking. When you set the **KURO LINK** mode to **OFF**, you can skip this process. For details about the **KURO LINK** feature, see *KURO LINK* on page 79.

Chapter 4: Basic Setup

Changing the OSD display language (OSD Language)

The language used on the Graphical User Interface screen can be changed.

- The explanations in these operating instructions are for when English is selected for the GUI screen.

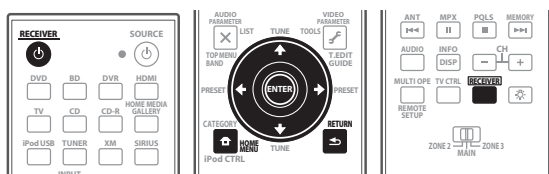

1 Switch on the receiver and your TV.

Use **RECEIVER** to switch on.

2 Press **RECEIVER** on the remote control, then press **HOME MENU**.

A Graphical User Interface (GUI) screen appears on your TV. Use **↑/↓/←/→** and **ENTER** to navigate through the screens and select menu items. Press **RETURN** to exit the current menu.

3 Select 'System Setup' from the HOME MENU.

4 Select 'OSD Language' from the System Setup menu.

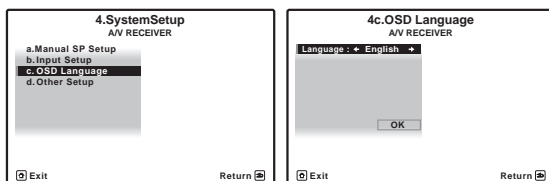

5 Select the desired language.

- English
- French
- German
- Italian
- Spanish
- Dutch
- Russian

6 Select 'OK' to change the language.

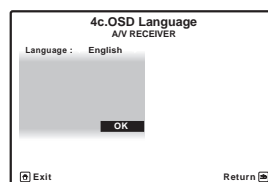

The setting is completed and the **System Setup** menu reappears automatically.

Automatically setting up for surround sound (Auto MCACC & Full Band Phase Control)

The Auto MCACC Setup measures the acoustic characteristics of your listening area, taking into account ambient noise, speaker connection and speaker size, and tests for both channel delay and channel level. After you have set up the microphone provided with your system, the receiver uses the information from a series of test tones to optimize the speaker settings and equalization for your particular room, and also to calibrate the frequency-phase characteristics of the speakers connected.

Make sure you do this before moving on to *Playing a source* on page 46.

Important

- Make sure the microphone and speakers are not moved during the Auto MCACC Setup.
- Using the Auto MCACC Setup will overwrite any existing settings for the MCACC preset you select.
- Before using the Auto MCACC Setup, the headphones should be disconnected and the iPod/USB, HOME MEDIA GALLERY, XM or SIRIUS Radio function should not be selected as an input function.

CAUTION

- The test tones used in the Auto MCACC Setup are output at high volume.

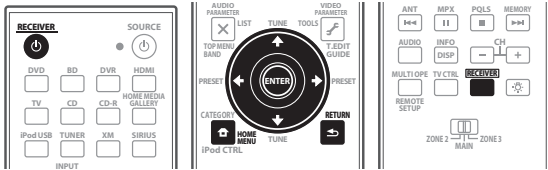

1 Switch on the receiver and your TV.

Use **RECEIVER** to switch on.

2 Connect the microphone to the MCACC SETUP MIC jack on the front panel.

- Push down on the lower portion of the front panel door to access the **MCACC SETUP MIC** jack.

Make sure there are no obstacles between the speakers and the microphone.

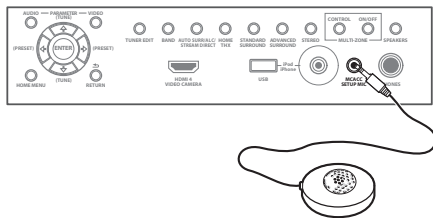

If you have a tripod, use it to place the microphone so that it's about ear level at your normal listening position. If you do not have a tripod, use some other object to install the microphone.¹

The Full Auto MCACC display appears once the microphone is connected.²

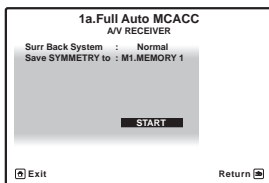

3 Press **RECEIVER to the receiver operation mode.**

Note

- 1 It may not be possible to measure correctly if the microphone is placed on a table, sofa, etc.
- 2 • You can't use the **HOME MENU** when the iPod/USB, HOME MEDIA GALLERY, XM or SIRIUS Radio input function is selected (in either the main or sub zone). When you set **ZONE 2**, **ZONE 3** or **ZONE 2&3** to **ON** (page 85), you can't use the **HOME MENU**.
 - If you leave the GUI screen for over five minutes, the screen saver will appear.
- 3 • For details on the speaker layout and the **Surr Back System** setting, see *Determining the speakers' application* on page 19.
 - If you are planning on bi-amping your front speakers, or setting up a separate speaker system in another room, read through *Surround back speaker setting* on page 109 and make sure to connect your speakers as necessary before continuing to step 5.
 - If you have THX-certified speakers, select **Return**, then select **Auto MCACC** for the THX Speaker setting. See *Automatic MCACC (Expert)* on page 96 for more on this.
- 4 The six MCACC presets are used for storing surround sound settings for different listening positions. Simply choose an unused preset for now (you can rename it later in *Data Management* on page 106).
- 5 Note that correction curves are saved only when set to **SYMMETRY**. Select **Return**, then select **Auto MCACC** to save other correction curves (such as **ALL CH ADJ** and **FRONT ALIGN**). See *Automatic MCACC (Expert)* on page 96 for more on this.
- 6 Do not adjust the volume during the test tones. This may result in incorrect speaker settings.

4 Select Surr Back System setting,³ select an MCACC preset⁴, then select **START.⁵**

Select **Normal** (Surround back), **Speaker B, Front Bi-Amp** or **ZONE 2** for the **Surr Back System** setting according to connections to the surround back speaker terminals.

5 Follow the instructions on-screen.

Make sure the microphone is connected, and if you're using a subwoofer, make sure it is switched on and set to a comfortable volume level.

6 Wait for the test tones to finish, then confirm the speaker configuration in the GUI screen.

A progress report is displayed on-screen while the receiver outputs test tones to determine the speakers present in your setup. Try to be as quiet as possible while it's doing this.⁶

If no operations are performed for 10 seconds while the speaker configuration check screen is being displayed, the Auto MCACC Setup will resume automatically. In this case, you don't need to select '**OK**' and press **ENTER** in step 7.

- With error messages (such as **Too much ambient noise!** or **Check microphone.**) select **RETRY** after checking for ambient noise (see *Problems when using the Auto MCACC Setup* below) and verifying the mic connection. If there doesn't seem to be a problem, you can simply select **GO NEXT** and continue.

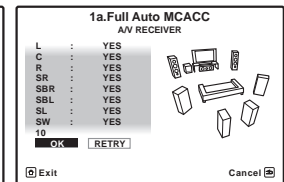
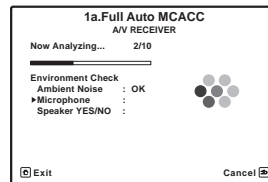

The configuration shown on-screen should reflect the actual speakers you have.

- If you see an **ERR** message (or the speaker configuration displayed isn't correct), there may be a problem with the speaker connection. If selecting **RETRY** doesn't work, turn off the power

and check the speaker connections. If there doesn't seem to be a problem, you can simply use **↑/↓** to select the speaker and **←/→** to change the setting and continue.

- If **Reverse Phase** is displayed, the speaker's wiring (+ and -) may be inverted. Check the speaker connections.¹
 - If the connections were wrong, turn off the power, disconnect the power cord, then reconnect properly. After this, perform the Full Auto MCACC procedure again.
 - If the connections were right, select **GO NEXT** and continue.

7 Make sure 'OK' is selected, then press ENTER.

A progress report is displayed on-screen while the receiver outputs more test tones to determine the optimum receiver settings for Channel Level, Speaker Distance, Standing Wave, Acoustic Cal EQ and Full Band Phase Control.

Again, try to be as quiet as possible while this is happening. It may take 3 to 10 minutes.

8 The Auto MCACC Setup procedure is completed and the Home Menu menu reappears automatically.²

Be sure to disconnect the microphone from this receiver upon completion of the Auto MCACC Setup.

The settings made in the Auto MCACC Setup should give you excellent surround sound from your system, but it is also possible to adjust these settings manually using *The Advanced MCACC menu* on page 95 or *The system and the other setup* on page 108.³

Problems when using the Auto MCACC Setup

If the room environment is not optimal for the Auto MCACC Setup (too much background noise, echo off the walls, obstacles blocking the speakers from the microphone) the final settings may be incorrect. Check for household appliances (air conditioner, fridge, fan, etc.), that may be affecting the environment and switch them off if necessary. If there are any instructions showing in the front panel display, please follow them.

- Some older TVs may interfere with the operation of the microphone. If this seems to be happening, switch off the TV when doing the Auto MCACC Setup.

The Input Setup menu

You only need to make settings in the **Input Setup** menu if you didn't hook up your digital equipment according to the default settings (see *Input function default and possible settings* on page 45). In this case, you need to tell the receiver what equipment is hooked up to which terminal so the buttons on the remote control correspond to the components you've connected.

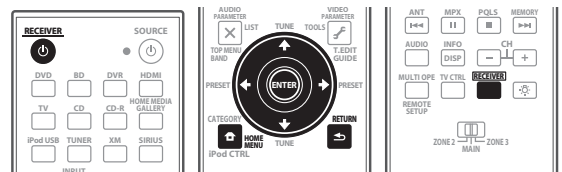

1 Switch on the receiver and your TV.

Use **RECEIVER** to switch on.

2 Press **RECEIVER** on the remote control, then press **HOME MENU**.

A Graphical User Interface (GUI) screen appears on your TV. Use **↑/↓/←/→** and **ENTER** to navigate through the screens and select menu items. Press **RETURN** to confirm and exit the current menu.

3 Select 'System Setup' from the HOME MENU.

4 Select 'Input Setup' from the System Setup menu.

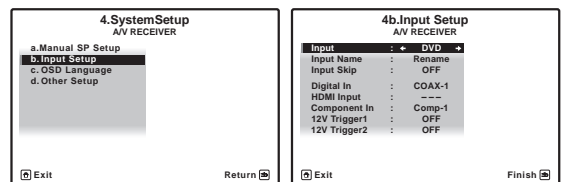

5 Select the input function that you want to set up.

The default names correspond with the names next to the terminals on the rear panel (such as **DVD** or **VIDEO1**) which, in turn, correspond with the names on the remote control.

Note

¹ If the speaker is not pointed to the microphone (listening position) or when using speakers that affect the phase (dipole speakers, reflective speakers, etc.), **Reverse Phase** may be displayed even if the speakers are properly connected.

² You can also choose to view the settings from the **MCACC Data Check** screen. See *Checking MCACC Data* on page 104 for more on this.

³ Depending on the characteristics of your room, sometimes identical speakers with cone sizes of around 12 cm (5 inches) will end up with different size settings. You can correct the setting manually using the *Manual speaker setup* on page 108.

- The subwoofer distance setting may be farther than the actual distance from the listening position. This setting should be accurate (taking delay and room characteristics into account) and generally does not need to be changed.

- If Auto MCACC Setup measurement results are incorrect due to the interaction of the speakers and viewing environment, we recommend adjusting the settings manually.

6 Select the input(s) to which you've connected your component.

For example, if your DVD player only has an optical output, you will need to change the **DVD** input function's **Digital In** setting from **COAX-1** (default) to the optical input you've connected it to. The numbering (**OPT-1 to 4**) corresponds with the numbers beside the inputs on the back of the receiver.

- If your component is connected via a component video cable to an input terminal other than the default, you must tell the receiver which input terminal your component is connected to, or else you may see the S-Video or composite video signals instead of the component video signals.¹

7 When you're finished, proceed to the settings for other inputs.

There are three optional settings in addition to the assignment of the input jacks:

- **Input Name** – You can choose to rename the input function for easier identification. Select **Rename** to do so, or **Default** to return to the system default.
- **Input Skip** – When set to **ON**, that input is skipped when selecting the input using **INPUT SELECT** or the front panel **INPUT SELECTOR** dial. (**DVD** and other inputs can be still be selected directly with the input function buttons.)
- **12V Trigger1/2** – After connecting a component to one of the 12 volt triggers (see *Switching components on and off using the 12 volt trigger* on page 38), select **MAIN**, **ZONE 2**, **ZONE 3** or **OFF** for the corresponding trigger setting to switch it on automatically along with the (main or sub) zone specified.

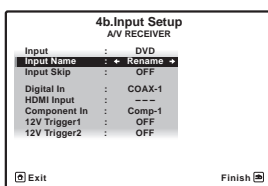

8 When you're finished, press RETURN. You will return to the System Setup menu.

Input function default and possible settings

The terminals on the receiver generally correspond to the name of one of the input functions. If you have connected components to this receiver differently from (or in addition to) the defaults below, see *The Input Setup menu* on page 44 to tell the receiver how you've connected up. The dots (●) indicate possible assignments.

Input function	Input Terminals		
	Digital	HDMI	Component
DVD	COAX-1	● ^a	IN 1
BD		(BD) ^b	
TV/SAT	OPT-1	● ^a	●
DVR	OPT-2	● ^a	IN 2
VIDEO1	OPT-3	● ^a	IN 3
VIDEO2	●	● ^a	●
HDMI 1		(HDMI-1)	
HDMI 2		(HDMI-2)	
HDMI 3		(HDMI-3)	
HDMI 4		(HDMI-4) ^b	
HOME MEDIA GALLERY			
iPod/USB			
XM			
CD	COAX-2		
CD-R/TAPE	OPT-4		
TUNER			
PHONO			
MULTI CH IN		● ^a	
SIRIUS	●		

a. With **KURO LINK** set to **ON**, assignments cannot be made (see *KURO LINK* on page 79).

b. This assignment is fixed and cannot be changed.

Note

¹ For high-definition video (using component video connections), or when digital video conversion is switched off (in *Setting the Video options* on page 83), you must connect your TV to this receiver using the same type of video cable as you used to connect your video component.

Chapter 5: Basic playback

Playing a source

Here are the basic instructions for playing a source (such as a DVD disc) with your home theater system.

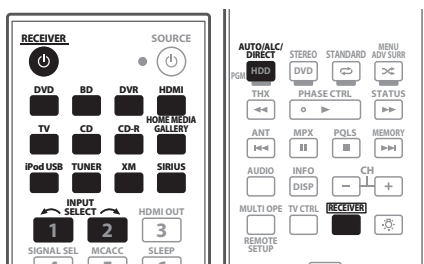

1 Switch on your system components and receiver.

Start by switching on the playback component (for example a DVD player), your TV¹ and subwoofer (if you have one), then the receiver (press **RECEIVER**).

- Make sure the setup microphone is disconnected.

2 Select the input function you want to play.

You can use the input function buttons on the remote control, **INPUT SELECT**, or the front panel **INPUT SELECTOR** dial.²

3 Press **RECEIVER**, then press **AUTO/ALC/DIRECT (AUTO SURR/ALC/STREAM DIRECT)** to select 'AUTO SURROUND' and start playback of the source.³

If you're playing a Dolby Digital or DTS surround sound DVD disc, you should hear surround sound. If you are playing a stereo source, you will only hear sound from the front left/right speakers in the default listening mode.

- See also *Listening to your system* on page 57 for information on different ways of listening to sources.

It is possible to check on the front panel display whether or not multi-channel playback is being performed properly.

When using a surround back speaker, **DOD+PLIIX MOVIE** is displayed when playing Dolby Digital 5.1 channel signals, and **DTS+Neo:6** is displayed when playing DTS 5.1-channel signals.

When not using a surround back speaker, **DOLBY DIGITAL** is displayed when playing Dolby Digital 5.1 channel signals.

If the display does not correspond to the input signal and listening mode, check the connections and settings.

4 Use the volume control to adjust the volume level.

Turn down the volume of your TV so that all sound is coming from the speakers connected to this receiver.

Playing a source with HDMI connection

- Use **INPUT SELECT** to select the HDMI input you've connected to (for example, HDMI 1).

You can also perform the same operation by using the **INPUT SELECTOR** dial on the front panel or by pressing **HDMI** on the remote control repeatedly.

- Set the HDMI parameter in *Setting the Audio options* on page 82 to **THROUGH** if you want to hear HDMI audio output from your TV or flat panel TV (no sound will be heard from this receiver).
- If the video signal does not appear on your TV or flat panel TV, try adjusting the resolution settings on your component or display. Note that some components (such as video game units) have resolutions that may not be converted. In this case, use an analog video connection.
- You can't hear HDMI audio through this receiver's digital out jack.

Note

¹ Make sure that the TV's video input is set to this receiver (for example, if you connected this receiver to the **VIDEO1** jacks on your TV, make sure that the **VIDEO1** input is now selected).

² If you need to manually switch the input signal type press **SIGNAL SEL** (page 63).

³ • You may need to check the digital audio output settings on your DVD player or digital satellite receiver. It should be set to output Dolby Digital, DTS and 88.2 kHz / 96 kHz PCM (2 channel) audio, and if there is an MPEG audio option, set this to convert the MPEG audio to PCM.
• Depending on your DVD player or source discs, you may only get digital 2 channel stereo and analog sound. In this case, the receiver must be set to a multichannel listening mode (see *Listening in surround sound* on page 57 if you need to do this) if you want multichannel surround sound.

Selecting the multichannel analog inputs

If you have connected a decoder or a DVD player as above, you must select the analog multichannel inputs for surround sound playback.¹

1 Make sure you have set the playback source to the proper output setting.

For example, you might need to set your DVD player to output multichannel analog audio.

2 Press **RECEIVER**, then use **INPUT SELECT** to select **MULTI CH IN**.

You can also use the **INPUT SELECTOR** dial on the front panel.

- Depending on the DVD player you're using, the analog output level of the subwoofer channel may be too low. In this case, the output level of the subwoofer can be increased by 10 dB in the **Multi Ch In Setup** in **Other Setup**. For details, see *Multi Channel Input Setup* on page 112.

Playing an iPod

This receiver has a dedicated iPod terminal that will allow you to control playback of audio content from your iPod using the controls of this receiver.²

1 Switch on the receiver and your TV.

See *Connecting an iPod* on page 40.

- It is also possible to operate the iPod on the iPod itself, without using the TV screen. For details, see *Switching the iPod controls* on page 48.

2 Press **iPod USB** on the remote control to switch the receiver to the iPod/USB.

Loading appears in the GUI screen while the receiver verifies the connection and retrieves data from the iPod.

When the display shows **iPod** top menu you're ready to play music from the iPod.³

Main Zone:

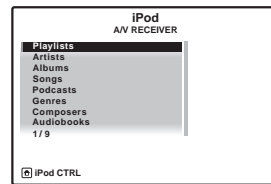

Sub Zone:



Playing back audio files stored on an iPod

To navigate songs on your iPod, you can take advantage of the GUI screen of your TV connected to this receiver.⁴ You can also control all operations for music in the front panel display of this receiver.

Finding what you want to play

When your iPod is connected to this receiver, you can browse songs stored on your iPod by playlist, artist name, album name, song name, genre or composer, similar to using your iPod directly.

1 Use **↑/↓** to select a category, then press **ENTER** to browse that category.

- To return to the previous level any time, press **RETURN**.

2 Use **↑/↓** to browse the selected category (e.g., albums).

- Use **←/→** to move to previous/next levels.

Note

- When playback from the multichannel inputs is selected, only the volume and channel levels can be set.
 - You can't listen to your speaker B system during playback from the multichannel inputs.
 - With **MULTI CH IN** inputs, it is possible to play pictures simultaneously. For details, see *Multi Channel Input Setup* on page 112.
- This system is compatible with the audio and video of the iPod nano, iPod fifth generation (audio only), iPod classic, iPod touch and iPhone. However, some of the functions may be restricted for some models. The system is not compatible with the iPod shuffle.
 - Compatibility may vary depending on the software version of your iPod and iPhone. Please be sure to use the latest available software version.
 - iPod and iPhone are licensed for reproduction of non-copyrighted materials or materials the user is legally permitted to reproduce.
 - Features such as the equalizer cannot be controlled using this receiver, and we recommend switching the equalizer off before connecting.
 - Pioneer cannot under any circumstances accept responsibility for any direct or indirect loss arising from any inconvenience or loss of recorded material resulting from the iPod failure.
 - When listening to a track on the iPod in the main zone, it is possible to control the sub zone, but not to listen to a different track in the sub zone from the one playing in the main zone.
- The controls of your iPod will be inoperable when connected to this receiver.
- Note that characters that cannot be displayed on this receiver are displayed as **#**.
 - This feature is not available for photos or video clips on your iPod. To display video clips, switch iPod operation to the iPod (see *Switching the iPod controls* on page 48).
 - If you leave the GUI screen for over five minutes, the screen saver will appear.

3 Continue browsing until you arrive at what you want to play, then press ► to start playback.¹

Main Zone:

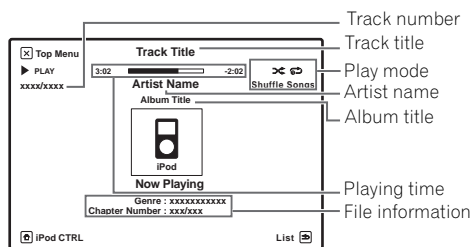

Sub Zone:

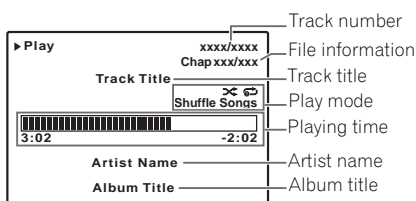

Navigation through categories on your iPod looks like this:

Playlists → Songs
 Artists → Albums → Songs
 Albums → Songs
 Songs
 Podcasts
 Genres → Artists → Albums → Songs
 Composers → Albums → Songs
 Audiobooks
 Shuffle Songs

Tip

- You can play all of the songs in a particular category by selecting the **All** item at the top of each category list. For example, you can play all the songs by a particular artist.

Basic playback controls

The following table shows the basic playback controls for your iPod. Press **iPod USB** to switch the remote control to the iPod/USB operation mode.

Button	What it does
►	Press to start playback. If you start playback when something other than a song is selected, all the songs that fall into that category will play.
	Pauses/unpauses playback.
◀◀/▶▶	Press and hold during playback to start scanning.
◀◀/▶▶	Press to skip to previous/next track.
↺	Press repeatedly to switch between Repeat One , Repeat All and Repeat Off .
↻	Press repeatedly to switch between Shuffle Songs , Shuffle Albums and Shuffle Off .
DISP	Press repeatedly to change the song playback information displayed in the front panel display.
ENTER	When browsing, press to move to next levels. During playback, press to set the play and pause modes.
RETURN	When browsing, press to move to previous levels.
◀/▶	When browsing, press to move to previous/next levels.
↑/↓	During Audiobook playback, press to switch the playback speed: Faster ↔ Normal ↔ Slower
TOP MENU	Press to return to the iPod top menu screen.

Switching the iPod controls²

You can switch over the iPod controls between the iPod and the receiver.

1 Press iPod CTRL to switch the iPod controls.³

This enables operation and display on your iPod, and this receiver's remote control and GUI screen become inactive.

2 Press iPod CTRL again to switch back to the receiver controls.

Note

¹ If you're in the song category, you can also press **ENTER** to start playback.

² You cannot use this function, when an iPod of fifth generation or iPod nano of first generation is connected.

³ When this function is set, iPod images cannot be played on this receiver. However, when video clips recorded on the iPod are played, the playback picture is displayed.

Playing a USB device

It is possible to playback files¹ using the USB interface on the front of this receiver.

1 Switch on the receiver and your TV.
See *Connecting a USB device* on page 40.²

2 Press iPod USB on the remote control to switch the receiver to the iPod/USB.

Loading appears in the GUI screen as this receiver starts recognizing the USB device connected.³ When the display shows **USB Top** menu you're ready to playback from the USB device.

Main Zone:

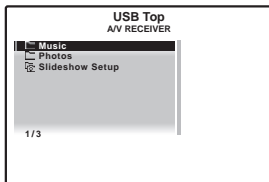

Sub Zone:

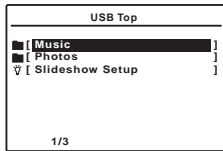

Important

If an **Over Current** message lights in the display, the power requirements of the USB device are too high for this receiver. Try following the points below:

- Switch the receiver off, then on again.
- Reconnect the USB device with the receiver switched off.
- Use a dedicated AC adapter (supplied with the device) for USB power.

If this doesn't remedy the problem, it is likely your USB device is incompatible.

Note

- Compatible USB devices include external magnetic hard drives, portable flash memory (particularly keydrives) and digital audio players (MP3 players) of format FAT12/16/32. It is not possible to connect this unit to a personal computer for USB playback.
 - Pioneer cannot guarantee compatibility (operation and/or bus power) with all USB mass storage devices and assumes no responsibility for any loss of data that may occur when connected to this receiver.
- Make sure the receiver is in standby when disconnecting the USB device.
- When a USB memory device with a large capacity is connected, it may take some time to read all the contents.
 - This receiver does not support a USB hub.
- Note that characters that cannot be displayed on this receiver are displayed as #.
- If the file selected cannot be played back, this receiver automatically skips to the next file playable.
 - When the file currently being played back has no title assigned to it, the file name is displayed in the GUI screen instead; when neither the album name nor the artist name is present, the row is displayed as a blank space.
 - Playback stops when the last song in a USB memory device is played back to the end.
 - Copyrighted audio files cannot be played back on this receiver.
 - DRM-protected audio files cannot be played back on this receiver.
 - If you leave the GUI screen for over five minutes, the screen saver will appear.

Playing back audio files stored on a USB memory device

The maximum number of levels that you can select in Step 2 (below) is 8. Also, you can display and play back up to 30 000 folders and files within a USB memory device.⁴

1 Use ↑/↓ to select 'Music' from the USB Top menu.

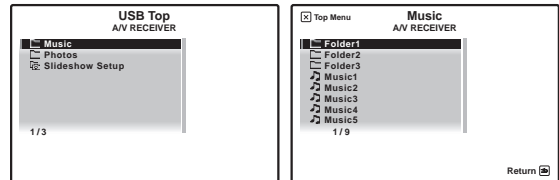

2 Use ↑/↓ to select a folder, then press ENTER to browse that folder.

- To return to the previous level any time, press **RETURN**.

3 Continue browsing until you arrive at what you want to play, then press ► to start playback.⁵

Main Zone:

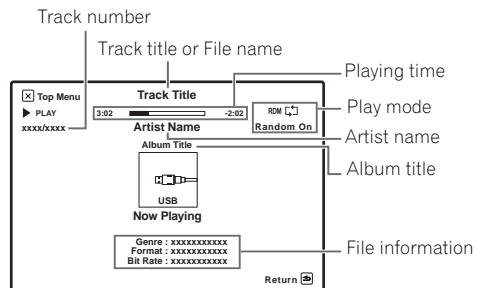

Sub Zone:

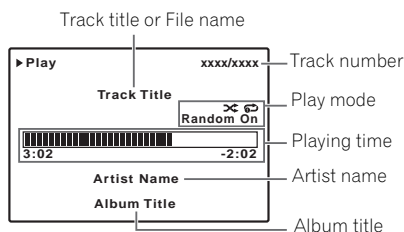

Basic playback controls

The following table shows the basic playback controls for your USB memory device. Press **iPod USB** to switch the remote control to the iPod/USB operation mode.

Button	What it does
▶	Press to start playback.
	Pauses/unpauses playback.
◀▶	Press and hold during playback to start scanning.
◀▶	Press to skip to previous/next track.
↻	Press repeatedly to switch between Repeat One , Repeat Folder , Repeat All and Repeat Off .
⌘	Press repeatedly to switch between Random On and Random Off .
DISP	Press repeatedly to change the song playback information displayed in the front panel display.
ENTER	When browsing, press to move to next levels. During playback, press to set the play and pause modes.
RETURN	When browsing, press to move to previous levels.
◀/▶	When browsing, press to move to previous/next levels.
TOP MENU	Press to return to the USB Top menu.

Playing back photo files stored on a USB memory device¹

1 Use **↑/↓** to select 'Photos' from the **USB Top** menu.

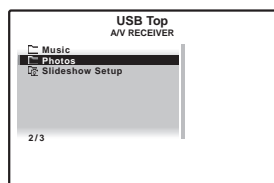

2 Use **↑/↓** to select a folder, then press **ENTER** to browse that folder.

- To return to the previous level any time, press **RETURN**.

3 Continue browsing until you arrive at what you want to play, then press **▶** to start playback.²

The selected content is displayed in full screen and starts a slideshow.

After a slideshow launches, pressing **ENTER** toggles between play and pause (only when **Theme** on the Slideshow Setup is set to **Normal (OFF)**).

Basic playback controls

Button	What it does
ENTER, ▶	Starts displaying a photo and playing a slideshow.
RETURN, ◀	Stops the Player and returns to the previous menu.
◀◀ ^a	Displays the previous photo content.
▶▶ ^a	Displays the next photo content.
^a	Pauses/unpauses the slideshow.
DISP ^a	Displays the photo information.

a.You can only use this button when **Theme** on the Slideshow Setup is set to **Normal (OFF)**.

Slideshow Setup

Make the various settings for playing slideshows of photo files here.

1 Use **↑/↓** to select 'Slideshow Setup' from the **USB Top** menu.

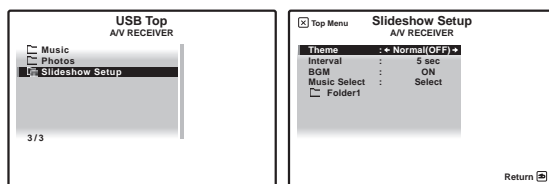

2 Select the setting you want.

- Theme** – Add various effects to the slideshow.
- Interval** – Set the interval for switching the photos. This may not be available depending on the **Theme** setting.
- BGM** – Play music files stored on the USB device while displaying photos.
- Music Select** – Select the folder containing the music files to be played when **BGM** is set to **ON**.

3 When you're finished, press **RETURN**.

You will return to the **USB Top** menu.

Note

1 Photo files cannot be played in the sub zone.

2 If the slideshow is left in the pause mode for five minutes, the list screen reappears.

About playable file formats

The USB function of this receiver supports the following file formats. Note that some file formats are not available for playback although they are listed as playable file formats.

Music files

Category	Extension	Stream		
MP3^a	.mp3	MPEG-1, 2, 2.5 Audio Layer-3	Sampling frequency	8 kHz to 48 kHz
			Quantization bitrate	16 bit
			Channel	2 ch
			Bitrate	8 kbps to 320 kbps
			VBR/CBR	Supported/Supported
WAV	.wav	LPCM	Sampling frequency	32 kHz, 44.1 kHz, 48 kHz
			Quantization bitrate	8 bit, 16 bit
			Channel	2 ch, Monaural
WMA	.wma	WMA8/g ^b	Sampling frequency	8 kHz to 48 kHz
			Quantization bitrate	16 bit
			Channel	2 ch
			Bitrate	8 kbps to 320 kbps
			VBR/CBR	Supported/Supported

a. "MPEG Layer-3 audio decoding technology licensed from Fraunhofer IIS and Thomson multimedia."

b. Files encoded using Windows Media Codec 9 may be playable but some parts of the specification are not supported; specifically, Pro, Lossless, Voice.

Photo files

Category	Extension		
JPEG	.jpg	Format	Meeting the following conditions: <ul style="list-style-type: none"> • Baseline JPEG format (including files recorded in Exif/DCF format) • Y:Cb:Cr - 4:4:4^a, 4:2:2 or 4:2:0
	.jpeg		
	.jpe		
	.jif		
	.jfif		
	Resolution	30 to 8192 pixels vertical, 40 to 8192 pixels horizontal	

a. The maximum playable resolution for 4:4:4 is 5120 x 8192 pixels.

Listening to the radio

The following steps show you how to tune in to FM and AM radio broadcasts using the automatic (search) and manual (step) tuning functions. If you already know the frequency of the station you want, see *Tuning directly to a station* below. Once you are tuned to a station you can memorize the frequency for recall later—see *Saving station presets* below for more on how to do this.

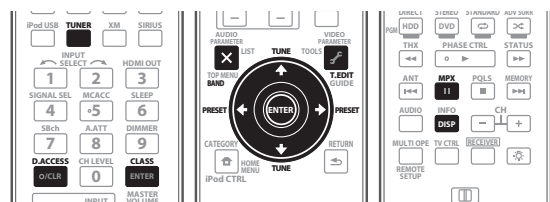

- 1 Press **TUNER** to select the tuner.
- 2 Use **BAND** to change the band (FM or AM), if necessary.

Each press switches the band between FM and AM.

- 3 Tune to a station.

There are three ways to do this:

Automatic tuning – To search for stations in the currently selected band, press and hold **TUNE** \uparrow/\downarrow for about a second. The receiver will start searching for the next station, stopping when it has found one. Repeat to search for other stations.

Manual tuning – To change the frequency one step at a time, press **TUNE** \uparrow/\downarrow .

High speed tuning – Press and hold **TUNE** \uparrow/\downarrow for high speed tuning. Release the button at the frequency you want.

Improving FM sound

If the **TUNED** or **STEREO** indicator doesn't light when tuning to an FM station because the signal is weak, press **MPX** to switch the receiver into mono reception mode. This should improve the sound quality and allow you to enjoy the broadcast.

Using the noise cut mode

The two noise cut modes can be used when receiving AM broadcasts. Press **MPX** to select the noise cut mode (1 to 2).

Using Neural THX

This feature uses Neural Surround™, THX® technologies to achieve optimal surround sound from FM radio.

- While listening to FM radio, press **AUTO/ALC/DIRECT** for Neural THX listening.

See *About Neural – THX Surround* on page 131 for more on this.

The **Neural THX** mode can be selected also with **STANDARD** (page 57).

Tuning directly to a station

Sometimes, you'll already know the frequency of the station you want to listen to. In this case, you can simply enter the frequency directly using the number buttons on the remote control.

- 1 Press **TUNER** to select the tuner.
- 2 Use **BAND** to change the band (FM or AM), if necessary.
- 3 Press **D.ACCESS** (Direct Access).
- 4 Use the number buttons to enter the frequency of the radio station.

For example, to tune to **106.00** (FM), press **1, 0, 6, 0, 0**.

If you make a mistake halfway through, press **D.ACCESS** twice to cancel the frequency and start over.

Saving station presets

If you often listen to a particular radio station, it's convenient to have the receiver store the frequency for easy recall whenever you want to listen to that station. This saves the effort of manually tuning in each time. This receiver can memorize up to 63 stations, stored in seven banks, or classes (A to G) of 9 stations each. When saving an FM frequency, the **MPX** setting (see page 52) is also stored.

- 1 Tune to a station you want to memorize.
- 2 Press **T.EDIT** (TUNER EDIT).
- 3 Press **CLASS** to select one of the seven classes, then press **PRESET** \leftarrow/\rightarrow to select the station preset you want.

You can also use the number buttons to select a station preset.

- 4 Press **ENTER**.

After pressing **ENTER**, the preset class and number stop blinking and the receiver stores the station.

Naming station presets

For easier identification, you can name your station presets.

- 1 Choose the station preset you want to name.
 - 2 Press **T.EDIT** (TUNER EDIT).
- The display shows **PRESET NAME**, then a blinking cursor at the first character position.

3 Input the name you want.

Choose from the following characters for a name up to eight characters long.

ABCDEFGHIJKLMN OPQRSTUVWXYZ

abcdefghijklmnopqrstuvwxyz

0123456789

!"#\$%&'()*+,-./:;<=>?@[\]^_{}~ [space]

Use **↑/↓** to select a character, **←/→** to set the position, and **ENTER** to confirm your selection.



Tip

- To erase a station name, simply repeat steps 1 to 3 and input eight spaces instead of a name.
- Once you have named a station preset, you can press **DISP** when listening to a station to switch the display between name and frequency.

Listening to station presets

You will need to have some presets stored to do this. See *Saving station presets* on page 52 if you haven't done this already.

- 1 Press **TUNER** to select the tuner.
- 2 Press **CLASS** to select the class in which the station is stored.
Press repeatedly to cycle through classes A to G.
- 3 Press **PRESET** **←/→** to select the station preset you want.
 - You can also use the number buttons on the remote control to recall the station preset.

Listening to Satellite Radio

To listen to Satellite Radio, you'll need to connect either a SIRIUS or XM Satellite Radio tuner (sold separately) to your satellite-ready receiver. Satellite Radio is available to residents of the US (except Alaska and Hawaii) and Canada.

Satellite Radio delivers a variety of commercial-free music from categories ranging from Pop, Rock, Country, R&B, Dance, Jazz, Classical and many more plus coverage of all the top professional and college sports including play by play games from select leagues and teams. Additional programming includes expert sports talk, uncensored entertainment, comedy, family programming, local traffic and weather and news from your most trusted sources.

Whether you purchase a SIRIUS or XM tuner, you'll need to activate and subscribe to begin enjoying the service. Easy to follow installation and setup instructions are provided with the satellite tuners. Whichever service you choose, there are a variety of programming packages available, including the option of adding "The Best of SIRIUS" programming to your XM tuner or "The Best of XM" programming to your SIRIUS tuner, enabling you to enjoy the most popular programming among both services. The "Best of" packages are not available to SIRIUS or XM Canada subscribers at this time.

Family friendly packages are also available to restrict channels featuring content that may be inappropriate for children.

To subscribe to XM, U.S. customers should visit xmradio.com or call 1-800-XMRADIO (1-800-967-2346); Canadian customers should visit xmradio.ca or call XM Listener Care at 1-877-GETXMSR (1-877-438-9677).

To subscribe to SIRIUS, U.S. and Canadian customers can call 1-888-539-SIRI (1-888-539-7474) or visit sirius.com (US) or siriuscanada.ca (Canada).

Listening to XM Radio

For details on XM Radio, see *About SIRIUS and XM* on page 131.

- Press **XM** to switch to the **XM RADIO** input. For best reception, you may need to move the XM Mini-Tuner antenna near a window (the southernmost window should produce the best results).
- If after pressing **XM** the display shows **Check XM Tuner** or **Check Antenna**, try disconnecting the receiver and tuner connections, and then plugging them back in.¹

After connecting, you will be able to use this receiver to select channels and navigate categories using the GUI screen.² The information displayed is as follows:

Main Zone:

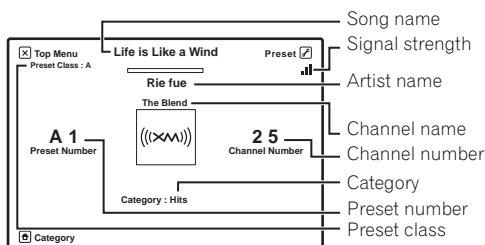

Note

- 1 You can check the strength of reception in *Using the XM Menu* (page 54).
- 2 It's easiest if you have your TV switched on to take advantage of the GUI screens. You can, however, use just the front panel display to do everything if you prefer.

Sub Zone:

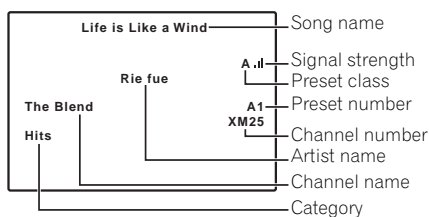

Selecting channels and browsing by genre

From the XM Channel Guide, you can browse XM Radio channels in the order that they appear, or you can narrow your channel search by genre.¹

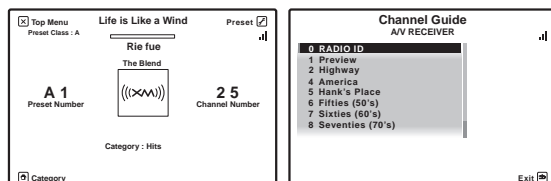

- Press **↑/↓** to enter the XM Channel Guide, navigate through the channels one at a time with **↑/↓**, then press **ENTER** to listen to the XM radio broadcast.
 - To browse by genre, first press **CATEGORY**, use **↑/↓** to select a genre, then press **ENTER**.
 - To cancel and exit any time, press **RETURN**.

Tip

- You can select channels directly by pressing **D.ACCESS**, then the three-digit channel number.
- You can press **DISP** to change XM Radio information in the front panel display.
- The currently selected channel is automatically chosen (without pressing **ENTER**) after five seconds.

Using XM HD Surround

XM HD Surround uses Neural Surround™, THX® technologies to achieve optimal surround sound from XM radio. XM HD Surround Sound is available on select XM channels only.

- While listening to XM Radio, press **AUTO/ALC/DIRECT** for XM HD Surround listening. See *About Neural – THX Surround* on page 131 for more on this.
- XM HD Surround can be selected also with **STANDARD**.

Saving channel presets

This receiver can memorize up to 63 channels, stored in seven banks, or classes (A to G) of nine channels each.²

- 1 **Select the channel you want to memorize.**
See *Selecting channels and browsing by genre* above.
- 2 **Press T.EDIT.**
The display shows a blinking memory class.
- 3 **Press CLASS** to select one of the seven classes, then press **←/→** to select the channel preset you want.
You can also use the number buttons to select a preset.
 - The default for all presets is **XM1**.
- 4 **Press ENTER.**
After pressing **ENTER**, the preset class and number stop blinking and the receiver stores the XM channel.

Tip

- You can also press **MEMORY** during reception display to save the information of up to five songs. See *Using the XM Menu* below to recall this information.

Listening to channel presets

- 1 **Press CLASS** to select the class in which the channel is stored.
Press repeatedly to cycle through classes A to G.
- 2 **Press ←/→** to select the channel preset you want.
 - You can also use the number buttons on the remote control to recall the channel preset.

Using the XM Menu

The XM Menu provides additional XM Radio features.³

- 1 **Press TOP MENU.**
- 2 **Use ↑/↓** to select a menu item, then press **ENTER.**
Choose from the following menu items:
 - **Channel Skip/Add** – Use **↑/↓** and **ENTER** to select channels you would like to remove/restore from/to the channel guide.
 - **Antenna Aiming** – Check the strength of satellite and terrestrial reception.
 - **Memory Recall** – Use **↑/↓** to browse your saved song information (see *Tip* on page 54).
- 3 **When you're finished press TOP MENU** to return to the reception display.

Note

- 1 Select **0 (RADIO ID)** from the GUI to check the Radio ID of the XM Mini-Tuner.
- 2 You can reset the Channel presets and memory in *Resetting the system* on page 88.
- 3 You can reset the Channel Skip/Add settings in *Resetting the system* on page 88.

Listening to SIRIUS Radio

For details on SIRIUS Radio, see *About SIRIUS and XM* on page 131.

- Press **SIRIUS** to switch to the SIRIUS input.

For best reception, you may need to move the SiriusConnect™ tuner antenna near a window (refer to the manual for the SiriusConnect™ Home tuner for antenna placement recommendations).¹

- If after pressing **SIRIUS** the display shows **Antenna Error**, try disconnecting the antenna and reconnecting.² If the display shows **Check Sirius Tuner**, check the connection of the AC adapter and this receiver to the SiriusConnect™ tuner.

After connecting, you will be able to use this receiver to select channels and navigate categories using the GUI screen display.³ The information displayed is as follows:
Main Zone:

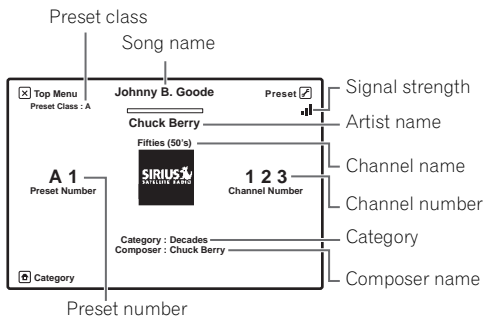

Sub Zone:

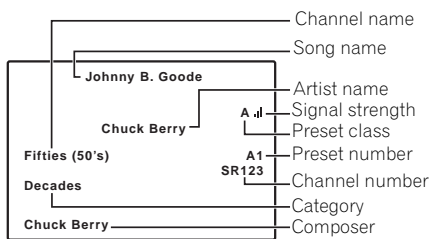

Selecting channels and browsing by genre

From the SIRIUS Channel Guide, you can browse SIRIUS Radio channels in the order that they appear, or you can narrow your channel search by genre.

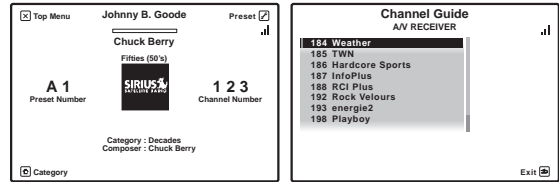

- Press **↑/↓** to enter the SIRIUS Channel Guide, navigate through the channels one at a time with **↑/↓**, then press **ENTER** to listen to the SIRIUS radio broadcast.

- To browse by genre, first press **CATEGORY**, use **↑/↓** to select a genre, then press **ENTER**.
- To cancel and exit any time, press **RETURN**.

Tip

- You can select channels directly by pressing **D.ACCESS**, then the three-digit channel number.
- You can press **DISP** to change SIRIUS Radio information in the front panel display.
- The currently selected channel is automatically chosen (without pressing **ENTER**) after five seconds.

Note

1 • In order to activate your radio subscription, you will need the SIRIUS ID (SID) which uniquely identifies your tuner. The SID may be found on a sticker located on the packaging, or on the bottom of the tuner itself. The label will have a printed 12-digit SID number. When you have located the SID, write it down in the space provided near the end of this manual. Contact SIRIUS on the internet at: <https://activate.siriusradio.com>

Follow the prompts to activate your subscription, or you can also call SIRIUS toll-free at 1-888-539-SIRIUS (1-888-539-7474).

• Select **0 (SIRIUS ID)** from the on-screen display to check the Radio ID of the SiriusConnect™ tuner (see *Selecting channels and browsing by genre* on page 55).

2 You can check the strength of reception in *Using the SIRIUS Menu* on page 56.

3 It's easiest if you have your TV switched on to take advantage of the GUI screens. You can, however, use just the front panel display to do everything if you prefer.

Saving channel presets

This receiver can memorize up to 63 channels, stored in seven banks, or classes (A to G) of nine channels each.¹

1 Select the channel you want to memorize.

See *Selecting channels and browsing by genre* on page 55.

2 Press T.EDIT.

The display shows a blinking memory class.

3 Press CLASS to select one of the seven classes, then press ←/→ to select the channel preset you want.

You can also use the number buttons to select a preset.

4 Press ENTER.

After pressing **ENTER**, the preset class and number stop blinking and the receiver stores the SIRIUS channel.¹



Tip

- You can also press **MEMORY** during reception display to save the information of up to five songs. See *Using the SIRIUS Menu* below to recall this information.

Listening to channel presets

1 Press CLASS to select the class in which the channel is stored.

Press repeatedly to cycle through classes A to G.

2 Press ←/→ to select the channel preset you want.

- You can also use the number buttons on the remote control to recall the channel preset.

Using the SIRIUS Menu

The SIRIUS Menu provides additional SIRIUS Radio features.²

1 Press TOP MENU.

2 Use ↑/↓ to select a menu item, then press ENTER.

Choose from the following menu items:

- Channel Skip/Add** – Use ↑/↓ and **ENTER** to select channels you would like to remove/restore from/to the channel guide.
- Parental Lock** – Use ↑/↓ and **ENTER** to select channels you would like to place under parental lock. Channels put under parental lock are not displayed in the Channel Guide, but may be accessed by directly inputting their channel number and providing the parental lock password.
- Antenna Aiming** – Check the strength of satellite and terrestrial reception.

- Memory Recall** – Use ↑/↓ to browse your saved song information (see *Tip* above).

- Password Set** – Set the parental lock password.

3 When you're finished press TOP MENU to return to the reception display.

Note

¹ You can reset the Channel presets and memory in *Resetting the system* on page 88.

² You can reset the Channel Skip/Add, Parental Lock and Password settings in *Resetting the system* on page 88.

Chapter 6:

Listening to your system

Auto playback

There are many ways to listen back to sources using this receiver, but for the simplest, most direct listening option is the Auto Surround feature. The receiver automatically detects what kind of source you're playing and selects multichannel or stereo playback as necessary.¹

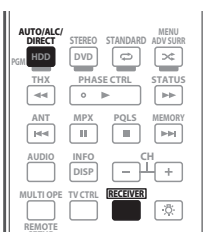

• While listening to a source, Press **RECEIVER**, then press **AUTO/ALC/DIRECT (AUTO SURR/ALC/STREAM DIRECT)**² for auto playback of a source. **AUTO SURROUND** shows briefly in the display before showing the decoding or playback format. Check the digital format indicators in the front panel display to see how the source is being processed.³

- If the source is Dolby Digital, DTS, or Dolby Surround encoded, the proper decoding format will automatically be selected and shows in the display.
- When listening to XM Radio, the XM HD Surround feature is selected automatically (see *Using XM HD Surround* on page 54 for more on this), and also when listening to the FM Radio, the Neural THX feature is selected automatically (see *Using Neural THX* on page 52 for more on this).

ALC – In the Auto level control (ALC) mode, this receiver equalizes playback sound levels.

OPTIMUM SURR – In the Optimum Surround mode, this receiver automatically optimizes sound balance in each scene based on actually set volume. The sound balancer controls three major theater sound elements dialogue, bass and surround with original algorithm.



- When an **ALC** is selected, the effect level can be adjusted using the **EFFECT** parameter in *Setting the Audio options* on page 82.

Listening in surround sound

Using this receiver, you can listen to any source in surround sound. However, the options available will depend on your speaker setup and the type of source you're listening to.

If you connected surround back speakers, see also *Using surround back channel processing* on page 61.

Standard surround sound

The following modes provide basic surround sound for stereo and multichannel sources.⁴

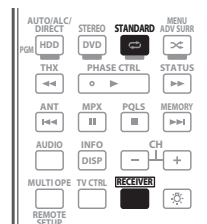

- While listening to a source, Press **RECEIVER**, then press **STANDARD (STANDARD SURROUND)**.⁵ If necessary, press repeatedly to select a listening mode.

Note

- Stereo surround (matrix) formats are decoded accordingly using **Neo:6 CINEMA** or **Pro Logic IIx MOVIE** (see *Listening in surround sound* above for more on these decoding formats).
 - The Auto Surround feature is canceled if you connect headphones.
- For more options using this button, see *Using Stream Direct* on page 60.
 - The **AUTO SURROUND** mode cannot be selected in the following cases:
 - When headphones are plugged in (except **ALC**).
 - When **MULTI CH IN** input is selected.
 - When the **HDMI** audio output parameter is set to **THROUGH** in *Setting the Audio options* on page 82.
- Neural THX is selected when Neural Radio is accessed with the HOME MEDIA GALLERY input. However, Stereo is selected when a category other than Neural Radio is accessed.
- In modes that give 6.1 channel sound, the same signal is heard from both surround back speakers.
- The **STANDARD** listening mode cannot be selected in the following cases:
 - When headphones are plugged in.
 - When **MULTI CH IN** input is selected.
 - When the **HDMI** audio output parameter is set to **THROUGH** in *Setting the Audio options* on page 82.

With two channel sources, you can select from¹:

- **Pro Logic IIx MOVIE** – Up to 7.1 channel sound, especially suited to movie sources
- **Pro Logic IIx MUSIC** – Up to 7.1 channel sound, especially suited to music sources²
- **Pro Logic IIx GAME** – Up to 7.1 channel sound, especially suited to video games
- **Pro Logic** – 4.1 channel surround sound (sound from the surround speakers is mono)
- **Neo:6 CINEMA** – 7.1 channel sound, especially suited to movie sources
- **Neo:6 MUSIC** – 7.1 channel sound, especially suited to music sources³
- **Neural THX** – Up to 7.1 channel sound, especially suited to music sources⁴
- **XM HD Surround** – Up to 7.1 channel sound, especially suited to music sources⁵

With multichannel sources, if you have connected surround back speaker(s) and have selected **SBch ON**, you can select (according to format):

- **Pro Logic IIx MOVIE** – See above (only available when you're using two surround back speakers)
- **Pro Logic IIx MUSIC** – See above
- **Dolby Digital EX** – Creates surround back channel sound for 5.1 channel sources and provides pure decoding for 6.1 channel sources (like Dolby Digital Surround EX)
- **DTS-ES** – Allows you to hear 6.1 channel playback with DTS-ES encoded sources
- **DTS Neo:6** – Allows you to hear 6.1 channel playback with DTS encoded sources

Note

- 1 If surround back channel processing (page 61) is switched **OFF**, or the surround back speakers are set to **NO** (this happens automatically if the *Surround back speaker setting* on page 109 is set to anything but **Normal**), **Pro Logic IIx** becomes **Pro Logic II** (5.1 channel sound).
- 2 When listening to 2-channel sources in Dolby Pro Logic IIx Music mode, there are three further parameters you can adjust: **C.WIDTH**, **DIMENSION** and **PANORAMA**. See *Setting the Audio options* on page 82 to adjust them.
- 3 When listening to 2-channel sources in Neo:6 Cinema or Neo:6 Music mode, you can also adjust the center image effect (see *Setting the Audio options* on page 82).
- 4 **Neural THX** can be selected for 2-channel signals for which the input signal is PCM (48 kHz or less), Dolby Digital, DTS or analog 2-channel sources.
- 5 **XM HD Surround** can be selected only with the XM input.
- 6 • When the function is set to **TUNER**, **iPod/USB**, **PHONO**, **HOME MEDIA GALLERY**, **XM** or **SIRIUS**, it is not possible to select **Pro Logic IIx GAME+THX GAMES** or **THX Select2 GAME**.
 - The THX mode cannot be selected in the following cases:
 - When headphones are plugged in.
 - When **MULTI CH IN** input is selected.
 - When the **HDMI** audio output parameter is set to **THROUGH** in *Setting the Audio options* on page 82.
 - When playing an SACD, **Pro Logic IIx MUSIC+THX MUSIC**, **Neo:6 MUSIC+THX MUSIC** and **THX Select2 MUSIC** can be selected.
 - If the settings other than **Front** and **SW** (Subwoofer) are set to **NO** at Speaker Setting, only **THX CINEMA**, **THX MUSIC** and **THX GAMES** can be selected.
- 7 Unavailable with only one surround back speaker connected.
- 8 **THX CINEMA**, **THX MUSIC** and **THX GAMES** can be selected when surround back processing is set to **SBch OFF**, when there is no surround back speaker, or when playing 6.1- and 7.1-channel sources.
- 9 When playing DTS-encoded sources, **Neo:6 CINEMA+THX CINEMA** can be selected, not **THX Surround EX**.

Using the Home THX modes

THX and Home THX are technical standards created by THX Ltd. for cinema and home theater sound. Home THX is designed to make home theater audio sound more like what you hear in a cinema.

Different THX options will be available depending on the source and the setting for surround back channel processing (see *Using surround back channel processing* on page 61 for more on this).

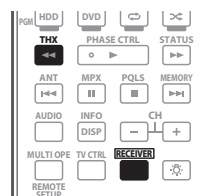

- Press **RECEIVER**, then press **THX (HOME THX)** to select a listening mode.⁶

With two channel sources, press **THX** repeatedly to select a matrix-decoding process for the **THX CINEMA** mode (see *Using surround back channel processing* on page 61 for an explanation of each process):

- **Pro Logic IIx MOVIE+THX CINEMA**
- **Pro Logic+THX CINEMA**
- **Neo:6 CINEMA+THX CINEMA**
- **Pro Logic IIx MUSIC+THX MUSIC**
- **Neo:6 MUSIC+THX MUSIC**
- **Pro Logic IIx GAME+THX GAMES**
- **THX Select2 GAMES**⁷

With multichannel sources, press **THX (HOME THX)** repeatedly to select from:⁸

- **THX Surround EX** – Allows you to hear 6.1 or 7.1 channel playback with 5.1 channel sources⁹

- **Pro Logic IIx MOVIE+THX CINEMA**
- **THX Select2 CINEMA**¹ – Allows you to hear 7.1 channel playback with 5.1 channel sources
- **Pro Logic IIx MUSIC+THX MUSIC**
- **THX Select2 MUSIC**¹ – This mode is suited not only for sources recorded in Dolby Digital and DTS, but also to all multi-channel music sources (DVD-Audio, etc.).
- **THX Select2 GAMES**¹ – This mode is suited to playing the sound of games.

Using the Advanced surround effects

The Advanced surround effects can be used for a variety of additional surround sound effects. Most Advanced Surround modes are designed to be used with film soundtracks, but some modes are also suited for music sources. Try different settings with various soundtracks to see which you like.

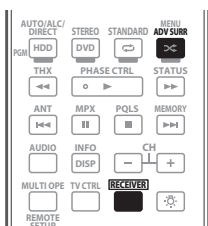

- Press **RECEIVER**, then press **ADV SURR** (ADVANCED SURROUND) repeatedly to select a listening mode.²

- **ACTION** – Designed for action movies with dynamic soundtracks
- **DRAMA** – Designed for movies with lots of dialog
- **SCI-FI** – Designed for science fiction with lots of special effects
- **MONO FILM** – Creates surround sound from mono soundtracks
- **ENT.SHOW** – Suitable for musical sources
- **EXPANDED** – Creates an extra wide stereo field³
- **TV SURROUND** – Provides surround sound for both mono and stereo TV sources
- **ADVANCED GAME** – Suitable for video games
- **SPORTS** – Suitable for sports programs
- **CLASSICAL** – Gives a large concert hall-type sound

- **ROCK/POP** – Creates a live concert sound for rock and/or pop music
- **UNPLUGGED** – Suitable for acoustic music sources
- **EXT.STEREO** – Gives multichannel sound to a stereo source, using all of your speakers
- **PHONES SURR** – When listening through headphones, you can still get the effect of overall surround.

Tip

- When an Advanced Surround listening mode is selected, the effect level can be adjusted using the **EFFECT** parameter in *Setting the Audio options* on page 82.

Listening in stereo

When you select **STEREO**, you will hear the source through just the front left and right speakers (and possibly your subwoofer depending on your speaker settings). Dolby Digital, DTS and WMA9 Pro multichannel sources are downmixed to stereo.

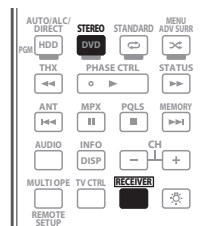

- While listening to a source, Press **RECEIVER**, then press **STEREO** for stereo playback.⁴ Press repeatedly to switch between:

- **STEREO** – The audio is heard with your surround settings and you can still use the Midnight, Loudness, and Tone functions.
- **F.S.SURR FOCUS** – See *Using Front Stage Surround Advance* on page 60 for more on this.
- **F.S.SURR WIDE** – See *Using Front Stage Surround Advance* on page 60 for more on this.

Note

- 1 Unavailable with only one surround back speaker connected.
- 2 Depending on the source and the sound mode you have selected, you may not get sound from the surround back speakers in your setup. For more on this, refer to *Using surround back channel processing* on page 61.
- 3 If you press **ADV SURR** when the headphones are connected, the **PHONES SURR** mode will automatically be selected.
- 3 Use with Dolby Pro Logic for a stereo surround effect (stereo field is wider than Standard modes with Dolby Digital sources).
- 4 The STEREO mode cannot be selected in the following cases:
 - When **MULTI CH IN** input is selected.
 - When the **HDMI** audio output parameter is set to **THROUGH** in *Setting the Audio options* on page 82.

Using Front Stage Surround Advance

The Front Stage Surround Advance function allows you to create natural surround sound effects using just the front speakers and the subwoofer.

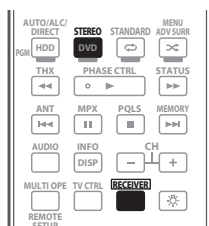

• While listening to a source, Press **RECEIVER**, then press **STEREO** to select Front Stage Surround Advance modes.¹

- **STEREO** – See *Listening in stereo* above for more on this.
- **F.S.SURR FOCUS** – Use to provide a rich surround sound effect directed to the center of where the front left and right speakers sound projection area converges.
- **F.S.SURR WIDE** – Use to provide a surround sound effect to a wider area than **FOCUS** mode.²

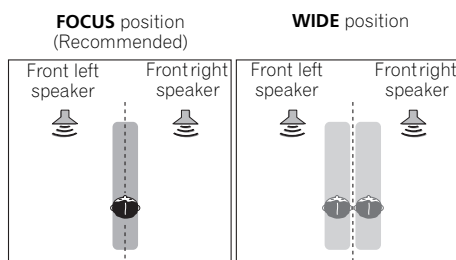

Using Stream Direct

Use the Stream Direct modes when you want to hear the truest possible reproduction of a source. All unnecessary signal processing is bypassed, and you're left with the pure analog or digital sound source.

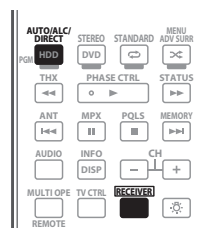

• While listening to a source, Press **RECEIVER**, then press **AUTO/ALC/DIRECT (AUTO SURR/ALC/STREAM DIRECT)** to select the mode you want.³

Check the digital format indicators in the front panel display to see how the source is being processed.

- **AUTO SURROUND** – See *Auto playback* on page 57.
- **ALC** – Listening in Auto level control mode (page 57).
- **DIRECT** – Sources are heard according to the settings made in the Surround Setup (speaker setting, channel level, speaker distance, acoustic calibration EQ, and X-curve), as well as with dual mono, the input attenuator, and any sound delay and hi-bit/hi-sampling settings. You will hear sources according to the number of channels in the signal.
- **PURE DIRECT** – Analog sources are heard without any digital processing.⁴ No sound is output from the Speaker B in this mode.
- **OPTIMUM SURR** – Listening in Optimum Surround mode (page 57).

Note

¹ The Front Stage Surround Advance mode cannot be selected in the following cases:

- When headphones are plugged in.
- When **MULTI CH IN** input is selected.
- When the **HDMI** audio output parameter is set to **THROUGH** in *Setting the Audio options* on page 82.

² When using **F.S.SURR WIDE**, a better effect can be obtained if the **Full Auto MCACC** procedure under **Advanced MCACC** is performed. For more on this, refer to *Automatically setting up for surround sound (Auto MCACC & Full Band Phase Control)* on page 42.

³ The Stream Direct mode cannot be selected in the following cases:

- When headphones are plugged in (except **PURE DIRECT**).
- When **MULTI CH IN** input is selected.
- When the **HDMI** audio output parameter is set to **THROUGH** in *Setting the Audio options* on page 82.

⁴ There are cases where a brief noise is heard before playback of sources other than PCM. Please select **AUTO SURROUND** or **DIRECT** if this is a problem.

Using surround back channel processing

- Default setting: **SBch ON**

You can have the receiver automatically use 6.1 or 7.1 decoding for 6.1 encoded sources (for example, Dolby Digital EX or DTS-ES), or you can choose to always use 6.1 or 7.1 decoding (for example, with 5.1 encoded material). With 5.1 encoded sources, a surround back channel will be generated, but the material may sound better in the 5.1 format for which it was originally encoded (in which case, you can simply switch surround back channel processing off).

- With a 7.1-channel surround system, audio signals that have undergone matrix decoding processing through surround back channel processing to which the Up Mix function is added are output from the surround back speakers.

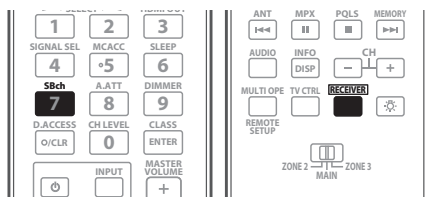

- Press **RECEIVER**, then press **SBch** repeatedly to cycle the surround back channel options.

Each press cycles through the options as follows:

- **SBch ON** – Matrix decoding processing for generating the surround back component from the surround component is turned on.
- **SBch AUTO** – Matrix decoding processing for generating the surround back component from the surround component is switched automatically. Matrix decoding processing is only performed when surround back channel signals are detected in the input signals.
- **SBch OFF** – Matrix decoding processing for generating the surround back component from the surround component is turned off.

Using the Virtual Surround Back mode

- Default setting: **OFF**

When you're not using surround back speakers, selecting this mode allows you to hear a virtual surround back channel through your surround speakers. You can choose to listen to sources with no surround back channel information, or if the material sounds better in the format (for example, 5.1) for which it was originally encoded, you can have the receiver only apply this effect to 6.1 encoded sources like Dolby Digital EX or DTS-ES.¹

- Press **RECEIVER**, then press **SBch** repeatedly to cycle the virtual surround back channel options.

Each press cycles through the options as follows:

- **VirtualSB ON** – Virtual Surround Back is always used (for example, on 5.1 encoded material)
- **VirtualSB AUTO** – Virtual Surround Back is automatically applied to 6.1 encoded sources (for example, Dolby Digital EX or DTS-ES)
- **VirtualSB OFF** – Virtual Surround Back mode is switched off

Note

- 1 • You can't use the Virtual Surround Back mode when the headphones are connected to this receiver or when any of the THX, stereo, Front Stage Surround Advance or Stream Direct mode is selected.
- You can only use the Virtual Surround Back mode if the surround speakers are on and the **SB** setting is set to **NO** or if **Front Bi-Amp, Speaker B** or **ZONE 2** is selected at **Surr Back System**.
- The Virtual Surround Back mode cannot be applied to sources that do not have surround channel information.

Setting the Up Mix function

In a 7.1-channel surround system with surround speakers placed directly at the sides of the listening position, the surround sound of 5.1-channel sources is heard from the side. The Up Mix function mixes the sound of the surround speakers with the surround back speakers so that the surround sound is heard from diagonally to the rear as it should be.¹

- Using the Up Mix function is effective when the speakers in the 7.1-channel surround system are set up as recommended in the example on page 20.
- Depending on the positions of the speakers and the sound source, in some cases it may not be possible to achieve good results. In this case, set the setting to **OFF**.

Up Mix OFF

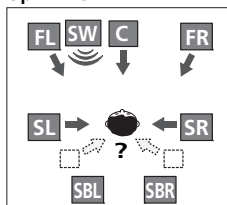

Up Mix ON

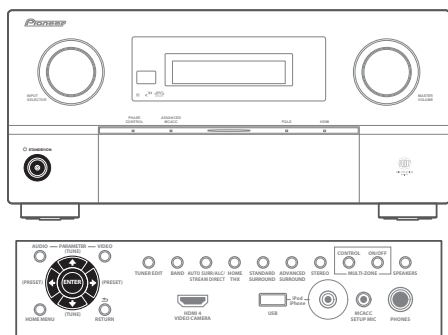
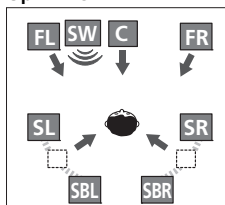

- 1 Switch the receiver into standby.
- 2 While holding down **ENTER** on the front panel, press **STANDBY/ON**.

The display shows **RESET ◀ NO ▶**.

Use **↑/↓** to select **UP MIX ◀ ON ▶**, and then use **←/→** to select **ON** or **OFF**.

- 3 Press **ENTER** to confirm.
 - When set to **ON**, the **UP MIX** indicator on the front panel lights.

Note

- 1 • Set to **ON** regardless of this setting when playing DTS-HD signals.
 - May automatically be set to **OFF** even when set to **ON**, depending on the input signal and listening mode.
- 2 Different presets might also have separate calibration settings for the same listening position, depending on how you're using your system. These presets can be set in *Automatically setting up for surround sound (Auto MCACC & Full Band Phase Control)* on page 42 or *Automatic MCACC (Expert)* on page 96, either of which you should have already completed.
- 3 • These settings have no effect when headphones are connected.
 - You can also press **←/→** to select the MCACC preset.

Selecting MCACC presets

- Default setting: **MEMORY 1**

If you have calibrated your system for different listening positions², you can switch between settings to suit the kind of source you're listening to and where you're sitting (for example, watching movies from a sofa, or playing a video game close to the TV).

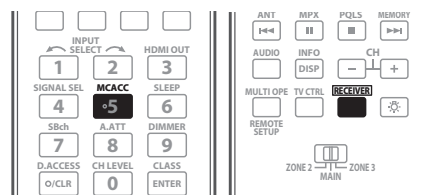

- While listening to a source, Press **RECEIVER**, then press **MCACC**.

Press repeatedly to select one of the six MCACC presets³. See *Data Management* on page 106 to check and manage your current settings.

Choosing the input signal

On this receiver, it is possible to switch the input signals for the different inputs as described below.¹

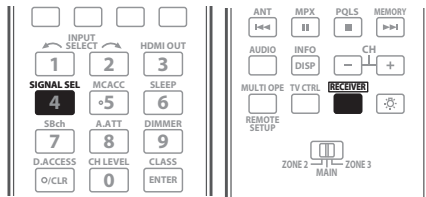

- Press **RECEIVER**, then press **SIGNAL SEL** to select the input signal corresponding to the source component.

Each press cycles through the options as follows:

- **AUTO** – The receiver selects the first available signal in the following order: **HDMI; DIGITAL; ANALOG**.
- **ANALOG** – Selects an analog signal.
- **DIGITAL** – Selects an optical or coaxial digital signal.
- **HDMI** – Selects an HDMI signal.²
- **PCM** – For PCM input signals.³ The receiver selects the first available signal in the following order: **HDMI; DIGITAL**.

When set to **DIGITAL**, **HDMI** or **AUTO** (only selected **DIGITAL** or **HDMI**), the indicators light according to the signal being decoded, as follows:

- **DIGITAL** lights with Dolby Digital decoding.
- **DIGITAL PLUS** lights with Dolby Digital Plus decoding.
- **TrueHD** lights with Dolby TrueHD decoding.
- **DTS** lights with DTS decoding.
- **DTS HD** lights with DTS-HD decoding.
- **MSTR** lights with DTS-HD Master Audio decoding.
- **96/24** lights with DTS 96/24 decoding.
- **WMA9 Pro** lights to indicate that a WMA9 Pro signal is being decoded.

- **HDMI** is not assigned by default. To select an HDMI signal, conduct the input setup procedure (see *The Input Setup menu* on page 44).

Note

1 • This receiver can only play back Dolby Digital, PCM (32 kHz to 192 kHz), DTS (including DTS 96/24) and WMA9 Pro digital signal formats. The compatible signals via the HDMI terminals are: Dolby Digital, DTS, WMA9 Pro, PCM (32 kHz to 192 kHz), Dolby TrueHD, Dolby Digital Plus, DTS-EXPRESS, DTS-HD Master Audio, SACD and DVD Audio (including 192 kHz). With other digital signal formats, set to **ANALOG** (the **MULTI CH IN**, **TUNER** and **PHONO**).

- You may get digital noise when a LD or CD player compatible with DTS is playing an analog signal. To prevent noise, make the proper digital connections (page 32) and set the signal input to **DIGITAL**.
 - Some DVD players don't output DTS signals. For more details, refer to the instruction manual supplied with your DVD player.
- 2 When the **HDMI** audio output parameter is set to **THROUGH**, the sound will be heard through your TV, not from this receiver.
- 3 • This is useful if you find there is a slight delay before **AUTO** recognizes the PCM signal on a CD, for instance.
- When **PCM** is selected, noise may be output during playback of non-PCM sources. Please select another input signal if this is a problem.

Better sound using Phase Control and Full Band Phase Control

This receiver is equipped with the two types of functions that correct phase distortion and group delay: Phase Control and Full Band Phase Control. Activating Full Band Phase Control is strongly recommended because it also involves the effects of Phase Control. For details on each of these two features, refer to the following explanations.

Using Phase Control

During multichannel playback, LFE (Low-Frequency Effects) signals as well as low-frequency signals in each channel are assigned to the subwoofer or the other most appropriate speaker. At least in theory, however, this type of processing involves a group delay that varies with frequency, resulting in phase distortion where the low-frequency sound is delayed or muffled by the conflict with other channels. With the Phase Control mode switched on, this receiver can reproduce powerful bass sound without deteriorating the quality of the original sound (see illustration below).

Phase Control OFF

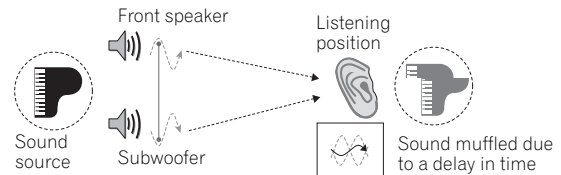

- Rhythms blurred and difficult to hear
- Bass sound with loss of depth
- Sound of musical instruments with no reality

Phase Control ON

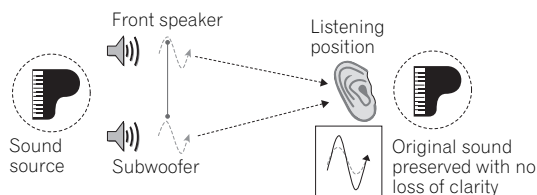

- Rhythms with crystal-like clarity
- Bass sound with no loss of depth
- Sound of musical instruments with superb reality

Phase Control technology provides coherent sound reproduction through the use of phase matching¹ for an optimal sound image at your listening position. The default setting is on and we recommend leaving Phase Control switched on for all sound sources.

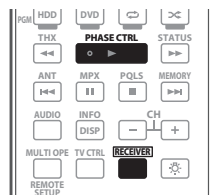

- Press **RECEIVER**, then press **PHASE CTRL (PHASE CONTROL)** to select **PHASE CONTROL**.

The  indicator on the front panel lights.

Using Full Band Phase Control

The Full Band Phase Control feature calibrates the frequency-phase characteristics of the speakers connected.

Standard speakers designed exclusively for audio use generally reproduce sound with the divided frequency bands output from a speaker system consisting of multiple speakers (in case of typical 3-way speakers, for instance, the tweeter, the squawker (midrange), and the woofer output sound in the high-, middle-, and low-frequency ranges, respectively). Though these speakers are designed to flatten the frequency-amplitude characteristics across wide ranges, there are cases where the group delay characteristics are not effectively flattened. This phase distortion of the speakers subsequently causes group delay (the delay of low-frequency sound against high-frequency sound) during audio signal playback.

This receiver analyzes the frequency-phase characteristics of the speakers by calibrating test signals output from the speakers with the supplied microphone, therefore flattening the analyzed frequency-phase characteristics during audio signal playback² – the same correction is made for a pair of left and right speakers. This correction minimizes group delay between the ranges of a speaker and improves the frequency-phase characteristics across all ranges.

Furthermore, the enhanced frequency-phase characteristics between channels ensure better surround sound integration for multichannel setting.³

Note

- Phase matching is a very important factor in achieving proper sound reproduction. If two waveforms are 'in phase', they crest and trough together, resulting in increased amplitude, clarity and presence of the sound signal. If a crest of a wave meets a trough (as shown in the upper section of the diagram above), then the sound will be 'out of phase' and an unreliable sound image will be produced.
 - The **PHASE CONTROL** feature is available even when the headphones are plugged in.
 - If your subwoofer has a phase control switch, set it to the plus (+) sign (or 0°). However, the effect you can actually feel when **PHASE CONTROL** is set to **ON** on this receiver depends on the type of your subwoofer. Set your subwoofer to maximize the effect. It is also recommended you try changing the orientation or the place of your subwoofer.
 - Set the built-in lowpass filter switch of your subwoofer to off. If this cannot be done on your subwoofer, set the cutoff frequency to a higher value.
 - If the speaker distance is not properly set, you may not have a maximized **PHASE CONTROL** effect.
 - The **PHASE CONTROL** mode cannot be set to **ON** in the following cases:
 - When the **PURE DIRECT** mode is switched on.
 - When the **MULTI CH IN** input is selected.
 - When the **HDMI** audio output parameter is set to **THROUGH** in *Setting the Audio options* on page 82.
- To calibrate and analyze the frequency-phase characteristics of the speakers, either follow the **Full Auto MCACC** procedure under **Advanced MCACC** (see *Automatically setting up for surround sound (Auto MCACC & Full Band Phase Control)* on page 42), or set **Auto MCACC** menu under **Auto MCACC** under **Advanced MCACC** to **Full Band Phase Ctrl**. Select **ALL** when you perform the **Auto MCACC** with **Auto MCACC** menu. Upon calibration of the frequency-phase characteristics of the speakers, the **Full Band Phase Ctrl** feature is automatically switched on. Note that **FULLBAND PHASE** cannot be selected unless the frequency-phase characteristics of the speakers are calibrated.
- The original characteristics of group delay of the speakers calibrated and the targeted characteristics after correction can be displayed graphically in the GUI screen (see *Using Full Band Phase Control* on page 64). Also, when your PC is connected to this receiver, the original characteristics of group delay of the speakers calibrated and the corrected characteristics of group delay can be displayed in 3-dimension on your PC (see *Output PC* on page 106).

Full Band Phase Control OFF

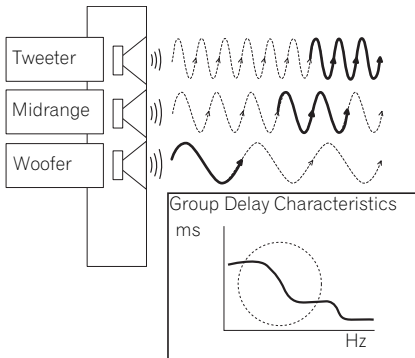

Sound in the middle- and low-frequency ranges is delayed against the high-frequency sound due to group delay.

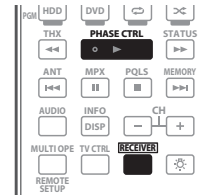

- Press **RECEIVER**, then press **PHASE CTRL (PHASE CONTROL)** to select **FULLBAND PHASE**.¹

Both the Phase Control and Full Band Phase Control functions are switched on. The **FULL BAND** and  indicator, on the front panel lights.

Full Band Phase Control ON

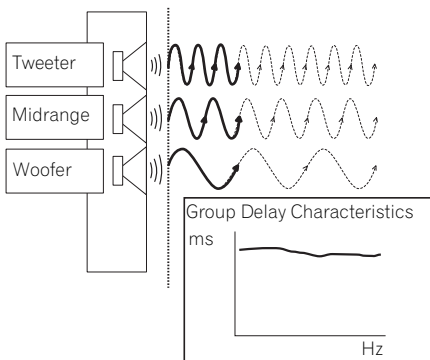

With the phase distortion corrected, the frequency-phase characteristics are improved across all ranges.

- Sound with live dynamics
- Sound of musical instruments with superb reality
- Sound so accurately reproduced that you can even hear the lip movement of the singer
- Speech heard with no loss of clarity
- Surround sound with excellent integration

Note

¹ The **Full Band Phase Ctrl** mode cannot be set to **ON** in the following cases:

- When headphones are plugged in.
- When the **PURE DIRECT** mode is switched on.
- When **MULTI CH IN** input is selected.
- When the **HDMI** audio output parameter is set to **THROUGH** in *Setting the Audio options* on page 82.

Chapter 7:

Playback with HOME MEDIA GALLERY inputs



Enjoying the Home Media Gallery

This receiver's Home Media Gallery function allows you to listen to audio files or listen to Internet radio stations on a computer or other component connected to the receiver's LAN terminal. This chapter describes the connection, setup, and playback procedures required to enjoy these features. It is advisory that you also refer to the operation manual supplied with your network component.

Features of Home Media Gallery

This receiver is equipped with the LAN terminal and you can enjoy the following features by connecting your components to these terminals.

- **Playback the music files stored in PCs¹**

You can playback a lot of music stored in your PCs using this unit.

→ See *Playback with Home Media Gallery* on page 69 and *Playing back audio files stored on components on the network* on page 70.

- **Listening to Internet radio stations**

You can select and listen to your favorite Internet radio station from the list of Internet radio stations created, edited, and managed by the vTuner database service exclusively for use with the Pioneer products.

→ See *Playback with Home Media Gallery* on page 69 and *Listening to Internet radio stations* on page 70.

- **Listening to Rhapsody, Sirius, Neural THX internet radio or Neural Music Direct**

→ See *Listening to Rhapsody* on page 72.

→ See *Listening to Sirius Internet Radio* on page 72.

→ See *Listening to Neural Music Direct* on page 72.

Steps to enjoy the Home Media Gallery

Playing back audio files on the network and listening to Internet radio stations

- 1 **Connect to the network through LAN interface.**

See *Connecting to the network through LAN interface* on page 67 for more on this.

- 2 **Configure the network settings.**

The setup is necessary only when the router to be connected does not have the built-in DHCP server function.

See *Setting up the network* on page 74 for more on this.

- 3 **Playback with Home Media Gallery.**

See *Playback with Home Media Gallery* on page 69 for more on this.

Note

¹ Besides a PC, you can also play back audio files stored on your other components with the built-in media server function based on DLNA 1.0 framework and protocols (i.e. network-capable hard disks and audio systems).

Connecting to the network through LAN interface

⚠ Caution

- Before making or changing the connections, switch off the power and disconnect the power cord from the power outlet. Plugging in should be the final step.

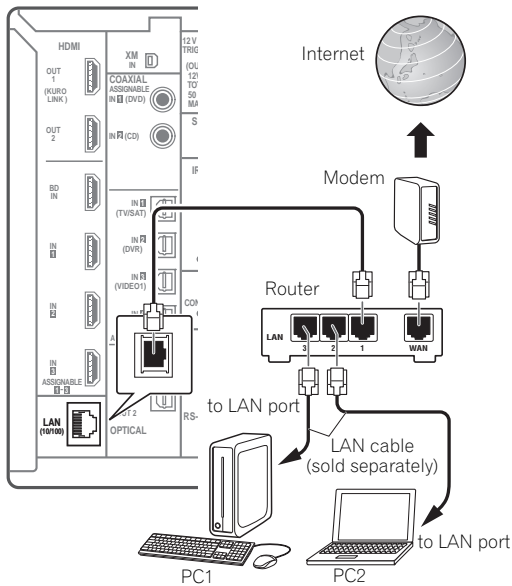

By connecting this receiver to the network via the LAN terminal, you can play back audio files stored on components on the network, including your PC, and listen to Internet radio stations.¹

Connect the LAN terminal on this receiver to the LAN terminal on your router (with or without the built-in DHCP server function) with a straight LAN cable (CAT 5 or higher).

Turn on the DHCP server function of your router. In case your router does not have the built-in DHCP server function, it is necessary set up the network manually. For details, see *Setting up the network* on page 74.

The specifications of a LAN terminal

LAN terminal Ethernet jack
10BASE-T/100BASE-TX

Introduction

The Home Media Gallery allows you to play music on media servers connected on an identical Local Area Network (LAN) as the receiver. This unit allows for the playing of files stored on the following:

- PCs running Microsoft Windows XP with Windows Media Connect installed
- PCs running Microsoft Windows Vista or XP with Windows Media Player 11 installed
- DLNA-compatible digital media servers (on PCs or other components)

To play back audio files stored on components on the network or listen to Internet radio stations, you must turn on the DHCP server function of your router. In case your router does not have the built-in DHCP server function, it is necessary to set up the network manually. Otherwise, you cannot play back audio files stored on components on the network or listen to Internet radio stations. See *Setting up the network* on page 74 for more on this.

Note

- ¹ To listen to Internet radio stations, you must sign a contract with an ISP (Internet Service Provider) beforehand.
- Photo or video files cannot be played back.
- With Windows Media Connect or Windows Media Player 11, you can even play back copyrighted audio files on this receiver.

About network playback

The network playback function of this unit uses the following technologies:

Windows Media Player

See *Windows Media Player 11/ Windows Media Connect* on page 78 for more on this.

Windows Media DRM

Microsoft Windows Media Digital Rights Management (WMDRM) is a platform to protect and securely deliver content for playback on computers, portable devices and network devices. Home Media Gallery functions as a WMDRM 10 for networked devices. WMDRM protected content can only be played on media servers supporting WMDRM.

Content owners use WMDRM technology to protect their intellectual property, including copyrights. This device uses WMDRM software to access WMDRM protected content. If the WMDRM software fails to protect the content, content owners may ask Microsoft to revoke the software's ability to use WMDRM to play or copy protected content. Revocation does not affect unprotected content. When you download licenses for protected content, you agree that Microsoft may include a revocation list with the licenses. Content owners may require you to upgrade WMDRM to access their content. If you decline an upgrade, you will not be able to access content that requires the upgrade. This product is protected by certain intellectual property rights of Microsoft. Use or distribution of such technology outside of this product is prohibited without a license from Microsoft.

DLNA



DLNA CERTIFIED™ Audio Player

The Digital Living Network Alliance (DLNA) is a cross-industry organization of consumer electronics, computing industry and mobile device companies. Digital Living provides consumers with easy sharing of digital media through a wired or wireless network in the home.

The DLNA certification logo makes it easy to find products that comply with the DLNA Interoperability Guidelines. This unit complies with DLNA Interoperability Guidelines v1.0.

When a PC running DLNA server software or other DLNA compatible device is connected to this player, some setting changes of software or other devices may be required. Please refer to the operating instructions for the software or device for more information.

DLNA and DLNA CERTIFIED are trademarks and/or service marks of Digital Living Network Alliance.

Content playable over a network

- Even when encoded in a compatible format, some files may not play correctly.
- Movie or Photo files cannot be played back.
- There are cases where you cannot listen to an Internet radio station even if the station can be selected from a list of radio stations.
- Some functions may not be supported depending on the server type or version used.
- Supported file formats vary by server. As such, files not supported by your server are not displayed on this unit. For more information check with the manufacturer of your server.

About playback behavior over a network

- Playback may stall when the PC is switched off or any media files stored on it are deleted while playing content.
- If there are problems within the network environment (heavy network traffic, etc.) content may not be displayed or played properly (playback may be interrupted or stalled). For best performance, a 100BASE-TX connection between player and PC is recommended.
- If several clients are playing simultaneously, as the case may be, playback is interrupted or stalled.
- Depending on the security software installed on a connected PC and the setting of such software, network connection may be blocked.

Pioneer is not responsible for any malfunction of the player and/or the Home Media Gallery features due to communication error/malfunctions associated with your network connection and/or your PC, or other connected equipment. Please contact your PC manufacturer or Internet service provider.

"Windows Media™" is a trademark of Microsoft Corporation. This product includes technology owned by Microsoft Corporation and cannot be used or distributed without a license from Microsoft Licensing, Inc.

Microsoft®, Windows®Vista, Windows®XP, Windows®2000, Windows®Millennium Edition, Windows®98, and WindowsNT® are either registered trademarks or trademarks of Microsoft Corporation in the United States and/or other countries.

Authorizing this receiver

In order to be able to play with Home Media Gallery, this receiver must be authorized. This happens automatically when the receiver makes a connection over the network to the PC. If not, please authorize this receiver manually on the PC. The authorization (or permission) method for access varies depending on the type of server currently being connected. For more information on authorizing this receiver, refer to the instruction manual of your server.

Playback with Home Media Gallery

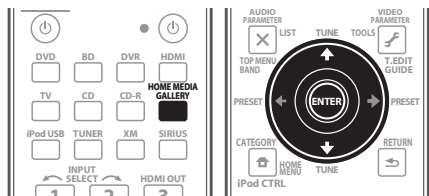

Important

- When you play back audio files, 'Connecting...' is displayed before playback starts. The display may continue for several seconds depending on the type of file.
- In case a domain is configured in a Windows network environment, you cannot access a PC on the network while you are logged onto the domain. Instead of logging onto the domain, log onto the local machine.
- There are cases where the time elapsed may not be correctly displayed.

1 Press HOME MEDIA GALLERY to select Home Media Gallery as the input function.

It may take several seconds for this receiver to access the network. The following screen appears when the Home Media Gallery is selected as the input function. The number next to indicates the number of connected servers.

Main Zone:

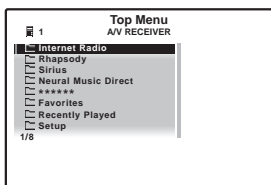

Sub Zone:

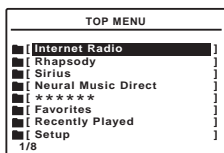

The server without the mark cannot be accessed.

2 Use ↑/↓ to select the category you want to play back, and then press ENTER.

Select a category from the following list:

- **Internet Radio** – Internet radio

- **Rhapsody** – Rhapsody music broadcast service
- **Sirius** – Internet radio that supports Sirius
- **Neural Music Direct** – Internet radio that supports Neural Surround
- **Server Name** – Server components on the network
- **Favorites** – Favorite songs currently being registered
- **Recently played** – Internet Radio listening history (most recent 20 incidents)

Depending on the selected category, the names of folders, files, and Internet radio stations are displayed.

3 Use ↑/↓ to select the folder, music files or Internet radio station to play back, and then press ENTER.

Press ↑/↓ to scroll up and down the list and select the desired item. When you press **ENTER**, playback starts with the playback screen being displayed for the selected item. To return to the list screen, press **RETURN**.¹

- In case of a server

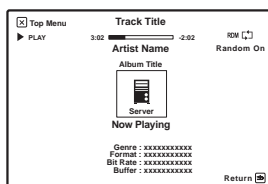
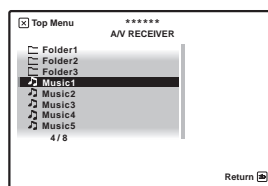



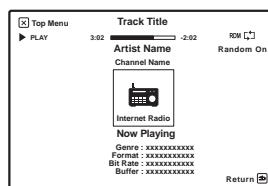
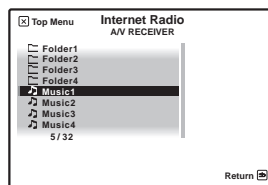

- In case of Internet radio



Note

¹ When the list screen is displayed from the playback screen, the playback screen reappears automatically if no operation is performed for 10 seconds while the list screen is displayed.

Only audio files with the  mark can be played. In case of the folders with the  mark, use / and **ENTER** to select the desired folder and audio files.

4 Repeat step 3 to play back the desired song.

For detailed operating instructions, refer to the section shown below.

- Internet radio stations – See *Listening to Internet radio stations* below.
- Rhapsody – See *Listening to Rhapsody* on page 72.
- Sirius – See *Listening to Sirius Internet Radio* on page 72.
- Neural Music Direct – See *Listening to Neural Music Direct* on page 72.
- Server – See *Playing back audio files stored on components on the network* below.

Playing back audio files stored on components on the network

About the playback screen

The following screen appears when you play back audio files. Note that some items may not be displayed depending on the type of file.

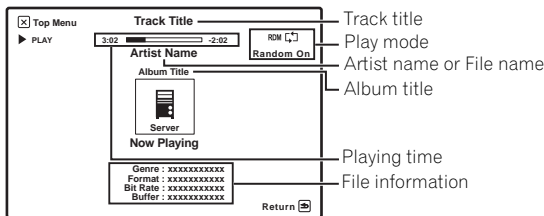

Main Zone:



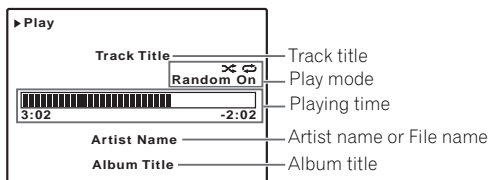



Sub Zone:



You can perform the following operations with the remote control of this receiver. Note that some buttons are not available for operation depending on the category currently being played back.

Button	Function
	Press to start playback. If you start playback when something other than a song is selected, all the songs that fall into that category will play.
	Pauses playback.
	Stops playback.

Button	Function
	Press to skip to previous/next song.
	Press repeatedly to switch among Repeat One , Repeat All and Repeat Off (available only during playback).
	Press repeatedly to switch between Random On and Random Off (available only during playback).
	When browsing, press to move to previous/next levels.
DISP	Press repeatedly to change the song playback information displayed in the front panel display. (If the list screen is displayed, switch to the playback screen.)
ENTER	When browsing, press to move to next levels. During playback, press to set the play and pause modes.
TOP MENU	Press to return to the Top Menu screen.
RETURN	Press to return to the previous level.

Listening to Internet radio stations

About Internet radio

Internet radio is an audio broadcasting service transmitted via the Internet. There are a large number of Internet radio stations broadcasting a variety of services from every corner of the world. Some are hosted, managed, and broadcast by private individuals while others are by the corresponding traditional terrestrial radio stations or radio networks. Whereas terrestrial, or OTA (over-the-air), radio stations are geographically restricted on the range of radio waves broadcast from a transmitter through the air, Internet radio stations are accessible from anywhere in the world, as long as there is a connection to the Internet, as services are not transmitted through the air but are delivered over the World Wide Web. On this receiver you can select Internet radio stations by genre as well as by region.

About the playback screen

The following screen appears when audio streams from an Internet radio station are received.

Main Zone:

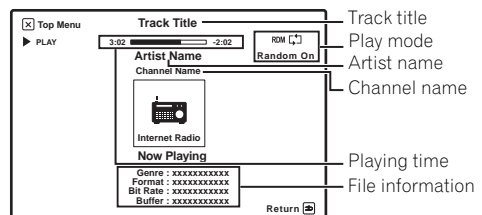

Sub Zone:

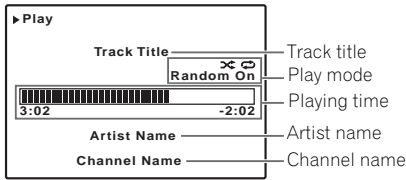

About list of Internet radio

The list of Internet radio stations on this receiver is created, edited, and managed by the vTuner database service exclusively for use with this receiver. For details about vTuner, see *vTuner* on page 77.

Saving and retrieving Internet radio stations

You can easily save and retrieve saved Internet radio stations. See *Advanced operations for Internet radio* on page 74 for more on this.¹

Registering broadcast stations not on the vTuner list from the special Pioneer site

With the receiver, broadcast stations not included on the list of station distributed by vTuner can be registered and played. Check the access code required for registration on the receiver, use this access code to access the special Pioneer Internet radio site and register the desired broadcast stations in your favorites. The address of the special Pioneer Internet radio site is: <http://www.radio-pioneer.com>

1 Display the Internet Radio list screen.

To display the Internet Radio list screen, perform steps 1 to 2 at *Playback with Home Media Gallery* on page 69.

2 Use \uparrow/\downarrow to select 'Help', then press ENTER.

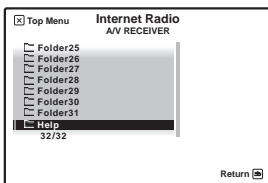

3 Use \uparrow/\downarrow to select 'Get access code', then press ENTER.

The access code required for registration on the special Pioneer Internet radio site is displayed. Make a memo of this address.

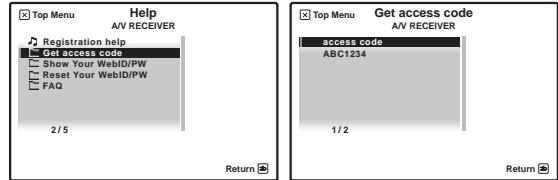

The following can be checked on the **Help** screen:

- **Get access code** – The access code required for registration on the special Pioneer Internet radio site is displayed.
- **Show Your WebID/PW** – After registering on the special Pioneer Internet radio site, the registered ID and password are displayed.
- **Reset Your WebID/PW** – Resets all the information registered on the special Pioneer Internet radio site. When reset, all the registered broadcast stations are also cleared. If you want to listen to the same stations, re-register after resetting.

4 Access the special Pioneer Internet radio site from your computer and perform the registration process.

<http://www.radio-pioneer.com>

Access the above site and use the access code in step 3 to perform user registration, following the instructions on the screen.

5 Register the desired broadcast stations as your favorites, following the instructions on the computer's screen.

Both broadcast stations not on the vTuner list and stations on the vTuner list can be registered. In this case they are registered on the receiver as favorite broadcast stations and can be played.

Note

- To listen to Internet radio stations, you must have high-speed broadband Internet access. With a 56 K or ISDN modem, you may not enjoy the full benefits of Internet radio.
 - The port number varies depending on the Internet radio station. Check the firewall settings.
 - A list of Internet radio stations provided by the vTuner database service is subject to change or deletion without notice due to various reasons.
 - Broadcasts may be stopped or interrupted depending on the Internet radio station. In this case, you cannot listen to a radio station selected from the list of Internet radio stations.

Listening to Rhapsody

About Rhapsody

Rhapsody is a paid digital music broadcast service provided by RealNetworks. Rhapsody offers 30-day free trial. Access the website in order to set up a trial account: <http://www.rhapsody.com/pioneer>

- You must have a registered account in order to listen to songs using Rhapsody. For details, see *Checking about the Accounts* on page 76.
- As of April 2009, the Rhapsody service is only offered in the United States.
- Some functions may be changed at Rhapsody's discretion.

Listening to Sirius Internet Radio

Check the website below to listen to Sirius Internet Radio: <http://www.sirius.com/siriusinternetradio>

- You must have a registered account in order to listen to songs using Sirius Internet Radio. For details, see *Checking about the Accounts* on page 76.
- Some functions may be changed at Sirius's discretion.

Listening to Neural Music Direct

About Neural Music Direct

Neural Music Direct is an Internet radio station managed and operated by Neural THX. Neural radio stations deliver multichannel surround sound. The Neural-THX Surround mode is automatically selected and lets you enjoy a rich multichannel surround sound experience. For details about Neural THX, see the operation manual supplied separately.



Neural Surround is a trademark owned by Neural Audio Corporation, THX is a trademark of THX Ltd., which may be registered in some jurisdictions. All rights reserved.

Playing back your favorite songs

About the Favorites folder

You can register up to 20 of your favorite songs or Internet radio stations in the Favorites folder. Note that only the audio files stored on components on the network can be registered.

Registering and deleting audio files and Internet radio stations in and from the Favorites folder

Press **PGM** while a song is being played back or stopped. The selected song is then registered in the Favorites folder.

Up to 20 songs or Internet radio stations can be registered.

To delete a registered song, select the Favorites folder, select the song you want to delete from the folder, and press **CLR**. The selected song is then deleted from the Favorites folder.

About playable file formats

The Home Media Gallery feature of this receiver supports the following file formats. Note that some file formats are not available for playback although they are listed as playable file formats. Also, the compatibility of file formats varies depending on the type of server. Check with your server to ensure the compatibility of file formats supported by your server.

Music files

Category	Extension	Stream		
MP3^a	.mp3	MPEG-1 Audio Layer-3	Sampling frequency	8 kHz to 48 kHz
			Quantization bitrate	16 bit
			Channel	2 ch
			Bitrate	8 kbps to 320 kbps
			VBR/CBR	Supported/Supported
LPCM	__b	LPCM	Sampling frequency	8 kHz to 44.1 kHz
			Quantization bitrate	16 bit, 20 bit, 24 bit
			Channel	2 ch
WAV	.wav	LPCM	Sampling frequency	8 kHz to 44.1 kHz
			Quantization bitrate	16 bit, 20 bit, 24 bit
			Channel	2 ch
WMA	.wma	WMA2/7/8	Sampling frequency	8 kHz to 48 kHz
			Quantization bitrate	16 bit
			Channel	2 ch
			Bitrate	5 kbps to 320 kbps
			VBR/CBR	Supported/Supported
		WMA9	Sampling frequency	8 kHz to 48 kHz
			Quantization bitrate	16 bit
			Channel	2 ch
			Bitrate	5 kbps to 320 kbps
			VBR/CBR	Supported/Supported
AAC	.m4a .aac .3gp .3g2	MPEG-4 AAC LC MPEG-4 HE AAC (aacPlus v1/2)	Sampling frequency	32 kHz to 48 kHz
			Quantization bitrate	16 bit
			Channel	2 ch
			Bitrate	16 kbps to 320 kbps
			VBR/CBR	Supported/Supported
FLAC	.flac	FLAC	Sampling frequency	8 kHz, 16 kHz, 22 kHz, 32 kHz, 44.1 kHz, 48 kHz
			Quantization bitrate	8 bit, 16 bit
			Channel	2 ch (8-bit monaural audio is not supported)
			Bitrate	—
			VBR/CBR	Not supported/Supported

a. "MPEG Layer-3 audio decoding technology licensed from Fraunhofer IIS and Thomson multimedia."

b. Only streaming data from servers is concerned, so there is no extension.

Advanced operations for Internet radio

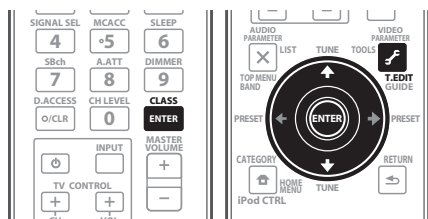

Saving Internet radio stations

This receiver can remember the Internet radio stations that you often listen to in seven classes (A to G) with up to nine stations in each class to make the total of 63 stations at its maximum capacity.

Before proceeding with the following steps, check whether you have followed Steps 1 to 3 on page 69.

1 Tune into the Internet radio station that you want to save.

Tune into the desired Internet radio station by following Steps 1 to 3 on page 69.

2 Press T.EDIT to switch to the station-saving mode.

3 Press CLASS to select the class that you want to save the station in.

Select the desired class from A to G.

4 Use ↑/↓ to select the number that you want to save the station as, and then press ENTER.

You can also select the station number by using the number buttons. Select the desired number from 1 to 9.

Retrieving saved Internet radio stations

You need to save Internet radio stations first before retrieving them. If there are no Internet radio stations currently being saved, see *Saving Internet radio stations* above and save at least one Internet radio station before proceeding with the following steps.

1 Select the class that you want to retrieve an Internet radio station from.

Each time you press **CLASS**, the class switches to A to G in turn.

2 Use ↑/↓ to select the station number that you want to retrieve.

You can also select the station number by using the number buttons.

'Preset Not Stored' appears when you select an Internet radio station currently not being saved.

Setting up the network

In case the router connected to the LAN terminal on this receiver is a broadband router (with the built-in DHCP server function), simply turn on the DHCP server function, and you will not need to set up the network manually. You must set up the network as described below only when you have connected this receiver to a server without the DHCP server function. Before you set up the network, consult with your ISP or the network manager for the required settings. It is advisory that you also refer to the operation manual supplied with your network component.¹

IP Address

The IP address to be entered must be defined within the following ranges. If the IP address defined is beyond the following ranges, you cannot play back audio files stored on components on the network or listen to Internet radio stations.

Class A: 10.0.0.1 to 10.255.255.254

Class B: 172.16.0.1 to 172.31.255.254

Class C: 192.168.0.1 to 192.168.255.254

Subnet Mask

In case an xDSL modem or a terminal adapter is directly connected to this receiver, enter the subnet mask provided by your ISP on paper. In most of the cases, enter 255.255.255.0.

Gateway IP

In case a gateway (router) is connected to this receiver, enter the corresponding IP address.

DNS Server Preferred/DNS Server Alternate

In case there is only one DNS server address provided by your ISP on paper, enter '**DNS Server Preferred**'. In case there are more than two DNS server addresses, enter '**DNS Server Alternate**' in the other DNS server address field.

Proxy Hostname/Proxy Port

This setting is required when you connect this receiver to the Internet via a proxy server. Enter the IP address of your proxy server in the '**Proxy Hostname**' field. Also, enter the port number of your proxy server in the '**Proxy Port**' field.

Note

¹ In case you make changes to the network configuration without the DHCP server function, make the corresponding changes to the network settings of this receiver.

Tip

- Press **↑/↓** or the numeric buttons to enter alphanumeric characters. To delete alphanumeric characters entered one at a time, press **←** or **CLEAR**. **'Cancel Key Editing Lose Changes?'** appears when you press **RETURN** or **←** while the cursor is placed in the leftmost position on the alphanumeric character entry screen. In this case, press **ENTER** to cancel the editing screen, **RETURN** to return to the editing screen.

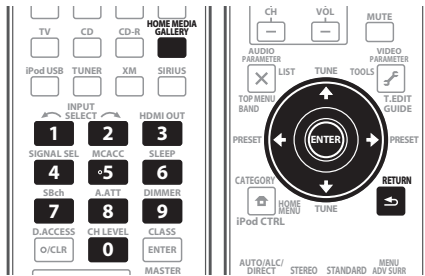

1 Press HOME MEDIA GALLERY to select 'Home Media Gallery' as the input function.

It may take several seconds for this receiver to access the network. The following screen appears when the Home Media Gallery is selected as the input function.



2 Select 'SETUP' and press ENTER to confirm your selection.

The **SETUP** screen appears.

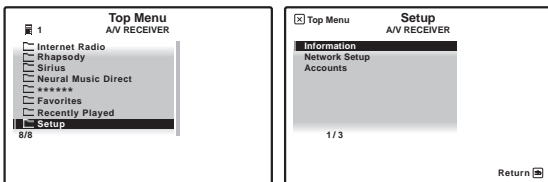

3 Select 'Network Setup' and press ENTER to confirm your selection.

The **Network Setup** screen appears.

4 Either 'Network Found' or 'No Network Found' appears. Check the network connection status and press ENTER.

- Network Found** – Connected to a component on the network.
- No Network Found** – Not connected to a component on the network.

The **Network IP Settings** screen appears.

5 Select 'Static IP Address' and press ENTER to confirm your selection.

The **IP address** screen appears. When you select **'Automatic (DHCP)'**, the network is automatically set up, and you do not need to follow Steps 6 to 7. Proceed with Step 8.

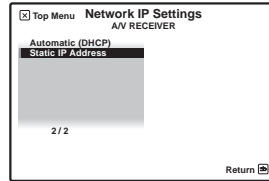

6 Select 'Change' and press ENTER to confirm your selection.

The **Edit IP address** screen appears.

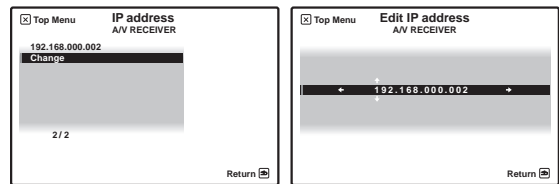

7 Enter the IP address.

Press **↑/↓** to select a number and **←/→** to move the cursor. After you select the last number, press **→** or **ENTER**. You can also use the numeric buttons to enter a number. The **Enable Proxy Server** screen appears.

8 Select 'No' or 'Yes' for the proxy server setting to deactivate or activate the proxy server.

In case you select **'No'**, proceed with Step 13. In case you select **'Yes'**, on the other hand, proceed with Step 9. The **Proxy Hostname** screen appears.

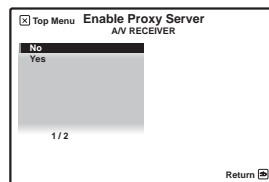

9 Select 'Change' and press ENTER to confirm your selection.

The **Edit Proxy Hostname** screen appears.

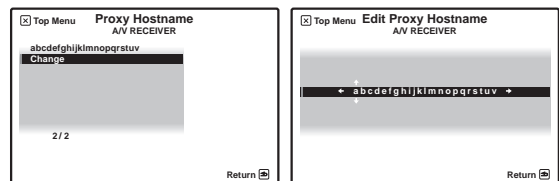

10 Enter the address of your proxy server or the domain name.

After entry, press **➡** or **ENTER**. The **Proxy Port** screen appears.

11 Select 'Change' and press ENTER to confirm your selection.

The **Edit Proxy Port** screen appears.

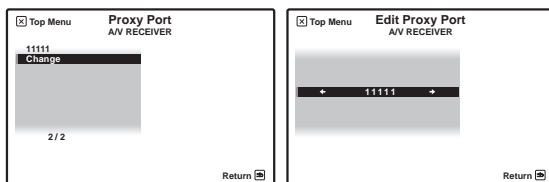

12 Enter the port number of your proxy server.

Use the numeric buttons to enter the port number. After entry, press **➡** or **ENTER**. The **Settings OK?** screen appears.

13 Press ENTER to complete the network setup procedure.

The **Top Menu** screen appears.

14 Switch off the receiver.

Use **⏻ RECEIVER** to switch off.

Checking the network settings

You can check the following network settings of this receiver: the MAC address, the IP address, the gateway IP address, the proxy server, the Subnet mask, and the firmware version (for the Home Media Gallery of this receiver).

Before proceeding with the following steps, check whether you have followed Steps from 1 to 2 on page 75.

1 Select 'Information' and press ENTER to confirm your selection.

The **Firmware Version** (for the Home Media Gallery of this receiver) screen appears.

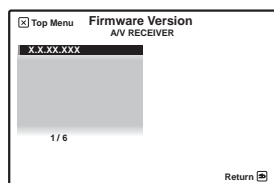

(The version of the illustration is not the latest.)

2 Check the network settings.

Press **↑/↓** to switch the display. Each time you press **↑/↓**, the display switches as follows.

Firmware Version ↔ **MAC Address** ↔ **IP address** ↔ **Subnet Mask** ↔ **Gateway IP** ↔ **Proxy Server**

3 Press RETURN.

The **Setup** screen appears. To return to the **Top Menu** screen, press **RETURN** again.

Checking about the Accounts

Screen concerning Rhapsody or Sirius Internet Radio account registration.

Before proceeding with the following steps, check whether you have followed Steps from 1 to 2 on page 75.

1 Select Accounts and press ENTER to confirm your selection.

2 Select Rhapsody or Sirius and press ENTER.¹

The contents below can be checked when Rhapsody is selected.

- Sign in to Rhapsody (Set Account)
- Account Info

The contents below can be checked when Sirius is selected.

- Set Account

When disposing of the product, we recommend you reset it to delete the data. See *Resetting the system* on page 88.

Software update

Information on software updates may be posted on the Pioneer website.

<http://www.pioneerelectronics.com>

Note

¹ Some operating procedures, etc., may be changed at the discretion of Rhapsody and Sirius.

Glossary

aacPlus

AAC decoder uses aacPlus developed by Coding Technologies. (www.codingtechnologies.com)



Default Gateway

Default Gateway is a node on a computer network that serves as an access point to another network. A default gateway (such as a computer and router) is used to forward all traffic that is not addressed to a station within the local subnet.

DHCP (Dynamic Host Configuration Protocol) Server

A DHCP server is a server that allocates IP addresses to hosts (network devices). In most cases, a broadband router serves as a DHCP server in a home network.

DLNA

The DLNA authorized logo makes it easy for consumers to recognize products that meet the new standard for home network PCs and other digital devices, as set down in the DLNA Guidelines for interoperability. This allows music, video, etc. to be enjoyed from various devices over a home network. This unit is compatible with music, photo and video content, and is based on the DLNA Home Networked Device Interoperability Guidelines v1.0. This unit can be used to playback music, photos and video stored on a DLNA-compatible server connected through a LAN cable.

Digital Living Network Alliance (DLNA) is dedicated to the simplified sharing of digital content, such as digital music, photos and video among networked consumer electronics (CE) and PCs. By establishing a platform of interoperability based on open industry standards, DLNA delivers technical design guidelines that companies can use to develop digital home products that share content through wired or wireless networks in the home.

DNS

DNS is an abbreviation for the Domain Name System, which stores and associates many types of information with domain names. Most importantly, DNS translates domain names (computer hostnames or sitenames, such as www.pioneerelectronics.com) to IP addresses (such as 202.221.192.106).

Ethernet

A frame-based computer networking technology for local area networks (LANs). This player supports 100BASE-TX and 10BASE-T.

FLAC

FLAC (Free Lossless Audio Codec) is an audio format allows lossless codec. Audio is compressed in FLAC without any loss in quality. For more details about FLAC, visit the following website: <http://flac.sourceforge.net/>

IP (Internet Protocol) address

A unique number that devices use in order to identify and communicate with each other on a network utilizing the Internet Protocol standard, such as '192.168.0.1'. No duplicate numbers are allowed in the network.

LAN

LAN is an abbreviation for the Local Area Network, which is a computer network covering a small geographical area, like a home, office, or group of buildings. Current LANs are most likely to be based on switched IEEE 802.3 Ethernet technology, running at 10, 100, or 1000 Mbit/s, or on IEEE 802.11 Wi-Fi technology.

MAC (Media Access Control) address

An address attached to the port of any network device with an IP address. The MAC address is expressed as "00:e0:36:xx:xx:xx" and cannot be changed.

Neural Surround

Neural Surround represents the latest advancement in surround technology and has been adopted by XM Satellite Radio, FM Radio and Neural Music Direct for broadcasts of surround recordings and live events.

Neural Surround employs psychoacoustic frequency domain processing which allows delivery of a more detailed sound stage with superior localization of surround elements. System playback is scalable from stereo up to state-of-the-art multichannel surround.

Subnet mask

The IP address is divided into the network address part and the host address part. The subnet mask is expressed as '255.255.255.0'. In most cases, the subnet mask is automatically assigned by the DHCP server.

vTuner

vTuner is a paid online database service that allows you to listen to radio and TV broadcasts on the Internet. vTuner lists thousands of stations from over 100 different countries around the globe. For more detail about vTuner, visit the following website: <http://www.radio-pioneer.com>

"This product is protected by certain intellectual property rights of NEMS and BridgeCo. Use or distribution of such technology outside of this product is prohibited without a license from NEMS and BridgeCo or an authorized subsidiary."

Windows Media

Windows Media is a multimedia framework for media creation and distribution for Microsoft Windows. Windows Media is either a registered trademark or trademark of Microsoft Corporation in the U.S. and/or other countries. Use an application licensed by Microsoft Corporation to author, distribute, or play Windows Media formatted content. Using an application unauthorized by Microsoft Corporation is subject to malfunction.

Windows Media DRM

Windows Media DRM is a DRM (Digital Rights Management) service for the Windows Media platform. It is designed to provide secure delivery of audio and/or video content over an IP network to a PC or other playback device in such a way that the distributor can control how that content is used. The WMDRM-protected content can only be played back on a component supporting the WMDRM service.

Windows Media Player 11/ Windows Media Connect

Windows Media Connect is software to deliver music, photos and movies from a Microsoft Windows XP computer to home stereo systems and TVs.

With this software, you can play back files stored on the PC through various devices wherever you like in your home.

At this time you cannot download the Windows Media Connect software from Microsoft's website. If your server currently does not have Windows Media Connect installed, install Windows Media Player 11 (for Windows XP) instead. This software can be downloaded from Microsoft's website.

For more information check the official Microsoft website.

Chapter 8:

KURO LINK

Synchronized operation with a KURO LINK-compatible Pioneer flat panel TV or Blu-ray disc player or with a component of another make that supports the KURO LINK function is possible when the component is connected to the receiver using an HDMI cable.

For details about concrete operations, settings, etc., refer to the operating instructions for each component.

- You cannot use this function with components that do not support KURO LINK.
- We do not guarantee this receiver will work with Pioneer KURO LINK-compatible components or components of other makes that support the KURO LINK function. We do not guarantee that all synchronized operations will work with components of other makes that support the KURO LINK function.
- Use a High Speed HDMI™ cable when you want to use the KURO LINK function. The KURO LINK function may not work properly if a different type of HDMI cable is used.
- To use the KURO LINK function, connect this receiver and flat panel TV using the **HDMI OUT 1** terminal. Connecting the KURO LINK compatible component using the **HDMI OUT 2** terminal may result in malfunction. If this happens, turn off the KURO LINK compatible component's KURO LINK setting.
- While the receiver is equipped with four HDMI inputs, the KURO LINK function can only be used with up to three DVD or Blu-ray disc players or up to three DVD or Blu-ray disc recorders.

Cautions on the KURO LINK function

- Connect the TV directly to this receiver. Interrupting a direct connection with other amps or an AV converter (such as an HDMI switch) can cause operational errors.
- Only connect components (Blu-ray disc player, etc.) you intend to use as a source to the HDMI input of this receiver. Interrupting a direct connection with other amps or an AV converter (such as an HDMI switch) can cause operational errors.
- When **KURO LINK** is set to **ON**, HDMI Input is automatically set to **OFF**.
- If a listening mode other than **AUTO SURROUND, ALC, DIRECT, PURE DIRECT, OPTIMUM SURROUND** or **STEREO** is selected while the PQLS effect is enabled, the PQLS effect is disabled.
- When this receiver is connected by HDMI cable to a Pioneer player that is compatible with the PQLS function via HDMI connection and HDMI reauthentication is performed (the **HDMI** indicator blinks), the PQLS effect is enabled and the listening mode is set to **AUTO SURROUND** if a listening mode other than **AUTO SURROUND, ALC, DIRECT, PURE DIRECT, OPTIMUM SURROUND** or **STEREO** is selected.
- When the receiver's **KURO LINK** is turned **ON**, even if the receiver's power is in the standby mode, it is possible to output the audio and video signals from a player via HDMI to the TV without producing sound from the receiver, but only when a KURO LINK-compatible component (Blu-ray disc player, etc.) and compatible TV are connected. In this case, the receiver's power turns on and the power and **HDMI** indicators light.

Making the KURO LINK connections

You can use synchronized operation for a connected flat panel TV and up to four other components.

Be sure to connect the flat panel TV's audio cable to the audio input of this unit.

For details, see *Connecting your TV and playback components* on page 26.

Important

- When connecting this system or changing connections, be sure to switch the power off and disconnect the power cord from the wall socket. After completing all connections, connect the power cords to the wall socket.
- After this receiver is connected to an AC outlet, a 2 second to 10 second HDMI initialization process begins. You cannot carry out any operations during initialization. The HDMI indicator on the display unit blinks during initialization, and you can turn this receiver on once it has stopped blinking.
- To get the most out of this function, we recommend that you connect your HDMI component not to a flat panel TV but rather directly to the HDMI terminal on this receiver.

About connections with a product of a different brand that supports the KURO LINK function

The synchronized operations below can be used when the receiver's KURO LINK function is connected to a TV of a brand other than Pioneer that supports the KURO LINK function. (Depending on the TV, however, some of the KURO LINK functions may not work.)

- You can set whether to output the sound over the speakers connected to the receiver or over the TV's speakers using the TV's menu screen.
- You can adjust the receiver's volume or mute the sound using the TV's remote control.
- When the TV's power is set to standby, the receiver's power is also set to standby. (Only when the input for a component connected to the receiver by HDMI connection is selected or when watching the TV)
- The sound of TV programs or an external input connected to the TV can also be output from the speakers connected to the receiver. (This requires connection of an optical digital cable, etc., in addition to the HDMI cable.)

The synchronized operations below can be used when the receiver's KURO LINK function is connected to a player or recorder of a brand other than Pioneer that supports the KURO LINK function.

- When playback starts on the player or recorder, the receiver's input switches to the HDMI input to which that component is connected.

See the Pioneer website for the latest information on the models of non-Pioneer brands and products that support the KURO LINK function.

KURO LINK Setup

You must adjust the settings of this receiver as well as KURO LINK-compatible connected components in order to make use of the KURO LINK function. For more information see the operating instructions for each component.

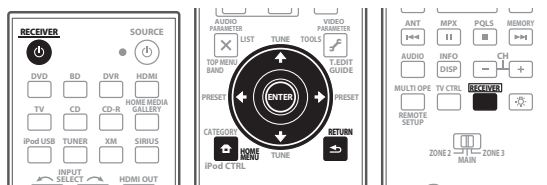

- 1 Press **RECEIVER**, then press **HOME MENU**.
- 2 Select 'System Setup', then press **ENTER**.
- 3 Select 'Other Setup', then press **ENTER**.

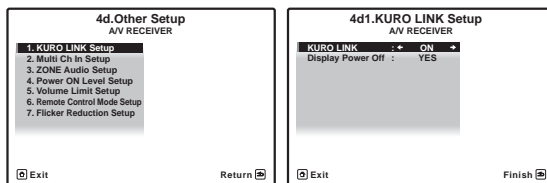

- 4 Select the 'KURO LINK' setting you want.

Choose whether to set this unit's KURO LINK function **ON** or **OFF**. You will need to set it to **ON** to use the KURO LINK function.

When using a component that does not support the KURO LINK function, set this to **OFF**.

- **ON** – Enables the KURO LINK function.
- **OFF** – The KURO LINK is disabled. Synchronized operations cannot be used.

- 5 Select the 'Display Power Off' setting you want.

If the TV's power is turned off while using the KURO LINK function, the receiver's power is also turned off (all power off function). This function can be disabled.

- **YES** – The all power off function is enabled. The receiver's power turns off together with the TV's power. This function only works when the input for a component connected to the receiver by HDMI connection is selected or when watching the TV.
- **NO** – The all power off function is disabled. The receiver's power is not affected when the TV's power is turned off.

- 6 When you're finished, press **HOME MENU**. You will finish to **HOME MENU**.

Setting the PQLS function

PQLS (Precision Quartz Lock System) is a digital audio signal transfer control technology using the KURO LINK function. It offers higher-quality audio playback by controlling audio signals from the receiver to a PQLS compatible player, etc. This enables removing jitter that has a negative effect on the quality of the sound and is generated upon transmission.

- On players compatible with PQLS Multi Surround, PQLS works for all sources. Set the player's audio output to Linear PCM.
- On players compatible with PQLS 2 ch Audio, PQLS only works when playing CDs.

Please refer to the operating instructions supplied with your player for more information.

This function is activated when **KURO LINK** is set to **ON**.

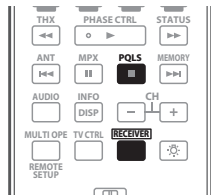

1 Set the remote control to the receiver operation mode, then press PQLS to select PQLS setting.

The setting is displayed on the front panel display.

- **PQLS AUTO** – PQLS is enabled. A precision quartz controller in this receiver eliminates distortion caused by timing errors (jitter), giving you the best possible digital-to-analog conversion when you use the HDMI interface. This is valid as an HDMI function for PQLS-compatible players.
- **PQLS OFF** – PQLS is disabled.

Before using synchronization

Once you have finished all connections and settings, you must:

- 1 Put all components into standby mode.
- 2 Turn the power on for all components, with the power for the flat panel TV being turned on last.
- 3 Choose the HDMI input to which the TV is connected to this receiver, and see if video output from connected components displays properly on the screen or not.
- 4 Check whether the components connected to all HDMI inputs are properly displayed.

Synchronized amp mode

The synchronized amp mode can be set from the KURO LINK-compatible TV's remote control. See the explanation below for operations in the synchronized amp mode.

These functions are set from the TV's menu screen. For more information, refer to the operating instructions of the KURO LINK-compatible TV.

Synchronized amp mode operations

When using the synchronized amp mode, the KURO LINK-compatible component connected to the receiver operates in sync as described below.

- The receiver's volume can be set and the sound can be muted using the TV's remote control.
- When the TV's power is set to standby, the receiver's power is also set to standby. (Only when the input for a component connected to the receiver by HDMI connection is selected or when watching the TV)
- The receiver's input switches automatically when the KURO LINK-compatible component is played.
- The receiver's input switches automatically when the TV's channel is switched.
- The synchronized amp mode remains in effect even if the receiver's input is switched to a component other than one connected by HDMI.

The operations below can also be used on Pioneer KURO LINK-compatible flat panel TVs.

- When the receiver's volume is adjusted or the sound is muted, the volume status is displayed on the flat panel TV's screen.
- When the OSD language is switched on the flat panel TV, the receiver's language setting also switches accordingly.

Canceling synchronized amp mode

- When the synchronized amp mode is canceled, the receiver's power turns off if you were viewing an HDMI input or a TV program on the TV.
- When in the synchronized amp mode, the synchronized amp mode is canceled when the receiver's power is turned off. To turn the synchronized amp mode back on, select the synchronized amp mode using the TV's remote control.
- When in the synchronized amp mode, the synchronized amp mode is canceled if an operation that produces sound from the TV is performed from the TV's menu screen, if the receiver's HDMI output setting is changed, etc.

Chapter 9: Using other functions

Setting the Audio options

There are a number of additional sound settings you can make using the **AUDIO PARAMETER** menu. The defaults, if not stated, are listed in bold.

Important

- Note that if a setting doesn't appear in the **AUDIO PARAMETER** menu, it is unavailable due to the current source, settings and status of the receiver.

1 Press **RECEIVER**, then press **AUDIO PARAMETER**.

2 Use **↑/↓** to select the setting you want to adjust. Depending on the current status/mode of the receiver, certain options may not be able to be selected. Check the table below for notes on this.

3 Use **←/→** to set it as necessary.

See the table below for the options available for each setting.

4 Press **RETURN** to confirm and exit the menu.

Setting	What it does	Option(s)
MCACC (MCACC preset)	Selects your favorite MCACC preset memory when multiple preset memories are saved. When an MCACC preset memory has been renamed, the given name is displayed.	M1. MEMORY 1 to M6. MEMORY 6 Default: M1. MEMORY 1
EQ (Acoustic Calibration EQ)	Switches on/off the effects of EQ Pro.	ON <i>OFF^a</i>
S-WAVE (Standing Wave)	Switches on/off the effects of Standing Wave Control.	ON <i>OFF</i>
DELAY (Sound Delay)	Some monitors have a slight delay when showing video, so the soundtrack will be slightly out of sync with the picture. By adding a bit of delay, you can adjust the sound to match the presentation of the video.	0.0 to 10.0 (frames) <i>1 second = 30 frames (NTSC)</i> Default: 0.0
MIDNIGHT	Allows you to hear effective surround sound of movies at low volumes.	MIDNIGHT/LOUDNESS OFF <i>MIDNIGHT ON</i>
LOUDNESS	Used to get good bass and treble from music sources at low volumes.	<i>LOUDNESS</i> ON

Setting	What it does	Option(s)
TONE^b (Tone Control)	Applies the treble and bass tone controls to a source, or bypasses them completely.	BYPASS <i>ON</i>
BASS^c	Adjusts the amount of bass.	-6 to +6 (dB) Default: 0 (dB)
TREBLE^c	Adjusts the amount of treble.	-6 to +6 (dB) Default: 0 (dB)
S.RTRV (Sound Retriever)	With the Sound Retriever function, DSP processing is used to compensate for the loss of audio data upon compression, improving the sound's sense of density and modulation.	OFF^d <i>ON</i>
DNR (Digital Noise Reduction)	May improve the quality of sound in a noisy source (for example, video tape with lots of background noise) when switched on.	OFF <i>ON</i>
DIALOG E. (Dialog Enhancement)	Localizes dialog in the center channel to make it stand out from other background sounds in a TV or movie soundtrack.	OFF <i>ON</i>
HIBITSMP (High Bit/High Sampling)	Creates a wider dynamic range with digital sources like CDs or DVDs (Smoother, more delicate musical expression can be achieved by requantizing 16 bit PCM or 20 bit compressed audio signals to 24 bits)	OFF <i>ON</i>
DUAL (Dual Mono)	Specifies how dual mono encoded Dolby Digital soundtracks should be played. Dual mono is not widely used, but is sometimes necessary when two languages need to be sent to separate channels.	CH1 – Channel 1 is heard only CH2 – Channel 2 is heard only <i>CH1 CH2</i> – Both channels heard from front speakers
DRC (Dynamic Range Control)	Adjusts the level of dynamic range for movie soundtracks optimized for Dolby Digital, DTS, Dolby Digital Plus, Dolby TrueHD, DTS-HD and DTS-HD Master Audio (you may need to use this feature when listening to surround sound at low volumes).	AUTO^e <i>MAX</i> <i>MID</i> <i>OFF</i>

Setting	What it does	Option(s)
LFE (LFE Attenuate)	Some Dolby Digital and DTS audio sources include ultra-low bass tones. Set the LFE attenuator as necessary to prevent the ultra-low bass tones from distorting the sound from the speakers. The LFE is not limited when set to 0 dB, which is the recommended value. When set to -5 dB, -10 dB, -15 dB or -20 dB, the LFE is limited by the respective degree. When OFF is selected, no sound is output from the LFE channel.	0dB / -5dB/ -10dB/ -15dB/ -20dB ----- OFF
SACD GAIN^f	Brings out detail in SACDs by maximizing the dynamic range (during digital processing).	0dB ----- +6 dB
HDMI^g (HDMI Audio)	Specifies the routing of the HDMI audio signal out of this receiver (<i>amp</i>) or <i>through</i> to a TV or flat panel TV. When THROUGH is selected, no sound is output from this receiver.	AMPLIFIER ----- THROUGH
A.DELAY (Auto delay)	This feature automatically corrects the audio-to-video delay between components connected with an HDMI cable. The audio delay time is set depending on the operational status of the display connected with an HDMI cable. The video delay time is automatically adjusted according to the audio delay time. ^h	OFF ----- ON
C.WIDTHⁱ (Center Width) (Applicable only when using a center speaker)	Provides a better blend of the front speakers by spreading the center channel between the front right and left speakers, making it sound wider (higher settings) or narrower (lower settings).	0 to 7 Default: 3
DIMENSIONⁱ	Adjusts the depth of the surround sound balance from front to back, making the sound more distant (minus settings), or more forward (positive settings).	-3 to +3 Default: 0
PANORAMAⁱ	Extends the front stereo image to include the surround speakers for a 'wraparound' effect.	OFF ----- ON
C.IMAGE^j (Center Image) (Applicable only when using a center speaker)	Adjusts the center image to create a wider stereo effect with vocals. Adjust the effect from 0 (all center channel sent to front right and left speakers) to 10 (center channel sent to the center speaker only).	0 to 10 Defaults: Neo:6 MUSIC: 3 Neo:6 CINEMA: 10

Note

- ¹ • All of the setting items can be set for each input function.
• Setting items other than **V.CONV** can only be selected when **V.CONV** is set to **ON**.

Setting	What it does	Option(s)
EFFECT	Sets the effect level for the currently selected Advanced Surround or ALC mode (each mode can be set separately).	10 to 90 Defaults: 50 (90 for EXT.STEREO only)

- a. When **EQ OFF** is selected, the MCACC indicator does not light.
b. • Tone controls are disabled in THX listening modes.
• When you set the Tone Control function to **ON**, **MIDNIGHT/LOUDNESS** is set to **OFF**. In the same way, when you set **MIDNIGHT/LOUDNESS** to **ON**, the Tone Control function is set to **BYPASS**.
c. The adjustment can be made only when **TONE** is set to **ON**.
d. With the **iPod/USB** and **HOME MEDIA GALLERY** input function, by default **S.RTRV** is set to **ON**.
e. The initially set **AUTO** is only available for Dolby TrueHD signals. Select **MAX** or **MID** for signals other than Dolby TrueHD.
f. You shouldn't have any problems using this with most SACD discs, but if the sound distorts, it is best to switch the gain setting back to **0** dB.
g. • HDMI Audio setting cannot be switched while performing synchronized amp mode operations.
• The synchronized amp mode must be turned on in order to play the receiver's HDMI audio and video input signals from the TV with the receiver's power in the standby mode. See *Synchronized amp mode* on page 81.
h. This feature is only available when the connected display supports the automatic audio/video synchronizing capability ('lipsync') for HDMI. If you find the automatically set delay time unsuitable, set **A.DELAY** to **OFF** and adjust the delay time manually. For more details about the lipsync feature of your display, contact the manufacturer directly.
i. Only when listening to 2-channel sources in Dolby Pro Logic IIx Music/Dolby Pro Logic II Music mode.
j. Only when listening to 2-channel sources in Neo:6 MUSIC/CINEMA mode.

Setting the Video options

There are a number of additional picture settings you can make using the **VIDEO PARAMETER** menu. The defaults, if not stated, are listed in bold.



Important

- Note that if an option cannot be selected on the **VIDEO PARAMETER** menu, it is unavailable due to the current source, setting and status of the receiver.
- These functions do not affect inputs other than DVD, TV/SAT, DVR, VIDEO1, and VIDEO2.

1 Press **RECEIVER, then press VIDEO PARAMETER.**

2 Use **↑/↓ to select the setting you want to adjust.** Depending on the current status/mode of the receiver, certain options may not be able to be selected. Check the table (page 84) for notes on this.

3 Use **←/→ to set it as necessary.** See the table (page 84) for the options available for each setting.¹

4 Press RETURN to confirm and exit the menu.

Setting	What it does	Option(s)
V.CONV (Digital Video Conversion)	Converts video signals for output from the MONITOR OUT jacks (including HDMI OUT connector) for all video types (see page 25).	ON <i>OFF</i>
RES^a (Resolution)	Specifies the output resolution of the video signal (when analog video input signals are output at the HDMI OUT connector, select this according to the resolution of your monitor and the images you wish to watch).	AUTO <i>PURE</i> <i>480p/576p</i> <i>720p</i> <i>1080i</i> <i>1080p</i>
ASP^b (Aspect)	Specifies the aspect ratio when analog video input signals are output at the HDMI output. Make your desired settings while checking each setting on your display (if the image doesn't match your monitor type, cropping or black bands appear).	THROUGH <i>NORMAL</i>
PCINEMA^{c,d} (PureCinema)	This setting optimizes the picture for film material when the video output is set to progressive. Usually set to AUTO ; but try switching to OFF if the picture appears unnatural. Additionally, certain PAL movie video (576i, 25 frames/second STB video output or DVD disc playback, etc.) that contain film progressive material cannot be recognized as such by this receiver.	AUTO <i>PAL</i> <i>OFF</i>
P.MOTION^{c,d} (Progressive Motion)	Adjusts the motion and still picture quality when video output is set to progressive.	-4 to +4 Default: 0
YNR^c	Adjusts the amount of noise reduction (NR) applied to the Y (brightness) component.	0 to +8 Default: 0
DETAIL^c	Adjusts how sharp edges appear.	-4 to +4 Default: 0
SHARP^{c,e} (Sharpness)	Adjusts the sharpness of the high-frequency (detailed) elements in the picture.	-4 to +4 Default: 0
BRIGHT^c (Brightness)	Adjusts the overall brightness.	-6 to +6 Default: 0
CONTRAST^c	Adjusts the contrast between light and dark.	-6 to +6 Default: 0
HUE^{c,f}	Adjusts the red/green balance.	-6 to +6 Default: 0

Note

- The subwoofer output depends on the settings you made in *Manual speaker setup* on page 108. However, if **SP►B** is selected above, no sound is heard from the subwoofer (the LFE channel is not downmixed).
- Depending on the settings in *Surround back speaker setting* on page 109 output from the surround back pre-out terminals may change.
- All speaker systems (except **Speaker B** connections) are switched off when headphones are connected.

Setting	What it does	Option(s)
CHROMA^c (Chroma Level)	Adjusts saturation from dull to bright.	-6 to +6 Default: 0

- When set to a resolution with which the TV (monitor) is not compatible, no picture is output. Also, in some cases no picture will be output due to copyright protection signals. In this case, change the setting.
 - When **AUTO** is selected, the resolution is selected automatically according to the capacity of the TV (monitor) connected by HDMI.
 - When **PURE** is selected, the signals are output with the same resolution as when input (At this time, video signals are only output from the same type of terminals to which they were input).
 - When a display is connected by HDMI, if this is set to something other than **PURE** and 480i/576i analog signals are input, 480p/576p signals are output from the component output terminals.
 - Conversion to 1080p is only performed for 480i, 576i, 480p and 576p input signals.
- If the image doesn't match your monitor type, adjust the aspect ratio on the source component or on the monitor.
 - This cannot be set when the resolution is set to **PURE**.
 - NORMAL** setting is only displayed when 480i/p or 576i/p video signals are being input.
- This setting is only displayed when 480i or 576i video signals are being input.
- This setting is only valid for component outputs.
- This setting is not valid for HDMI outputs.
- This setting is not displayed for component inputs.

Switching the speaker system

If you selected **Speaker B** in *Surround back speaker setting* on page 109, three speaker system settings are possible using **SPEAKERS**. If you selected **Normal**, **Front Bi-Amp** or **ZONE 2**, the button will simply switch your main speaker system on or off. The options below are for the **Speaker B** setting only.¹

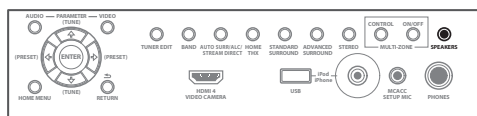

- Use **SPEAKERS** on the front panel to select a speaker system setting.

As mentioned above, if you have selected **Normal**, the button will simply switch your main speaker system (A) on or off.

Press repeatedly to choose a speaker system option:

- SP►A** – Sound is output from speaker system A and the same signal is output from the pre-out terminals.
- SP►B** – Sound is output from the two speakers connected to speaker system B. Multichannel sources will not be heard. The same signal is output from the surround back channel pre-out terminals.

Using other functions

- **SP►AB** – Sound is output from speaker system A (up to 5 channels, depending on the source), the two speakers in speaker system B, and the subwoofer. The sound from speaker system B will be the same as the sound from speaker system A (multichannel sources will be downmixed to 2 channels).
- **SP►** (off) – No sound is output from the speakers. The same sound is output from the pre-out terminals (including from your subwoofer, if connected) as when selecting speaker system A (above).

Using the MULTI-ZONE controls

The following steps use the front panel controls to adjust the sub zone volume and select sources. See *MULTI-ZONE remote controls* on page 85.

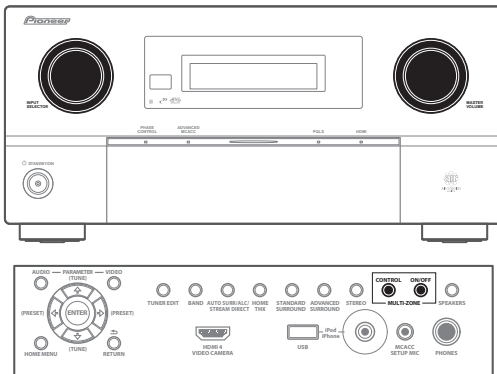

1 Press MULTI-ZONE ON/OFF on the front panel.

Each press selects a MULTI-ZONE option:

- **ZONE 2 ON** – Selects your primary (**ZONE 2**) sub zone
- **ZONE 2&3 ON** – Select both sub zones
- **ZONE 3 ON** – Selects your secondary (**ZONE 3**) sub zone
- **MULTI ZONE OFF** – Switches the MULTI-ZONE feature off

The **MULTI-ZONE** indicator lights when the MULTI-ZONE control has been switched ON.

2 Press MULTI-ZONE CONTROL on the front panel to select the sub zone(s) you want.

If you selected **ZONE 2&3 ON** above, you can toggle between **ZONE 2** and **ZONE 3**.

- When the receiver is on,¹ make sure that any operations for the sub zone are done while **ZONE** and your selected sub zone(s) show in the display. If this is not showing, the front panel controls affect the main zone only.

3 Use the INPUT SELECTOR dial to select the source for the zone you have selected.

For example, **ZONE 2 CD-R** sends the source connected to the **CD-R** inputs to the primary (**ZONE 2**) sub room.

- If you select **TUNER**, you can use the tuner controls to select a preset station (see *Saving station presets* on page 52 if you're unsure how to do this).²
- When using **ZONE 2** and **ZONE 3**, it is not possible to use the multi-zone function to play different inputs from among Home Media Gallery, iPod/USB, XM and SIRIUS Radio. (It is possible to play when using the main zone and **ZONE 2** or the main zone and **ZONE 3**.)

4 Use the MASTER VOLUME dial to adjust the volume for the zone you have selected.

This is only possible if you selected the **Variable** volume control in *ZONE Audio Setup* on page 113.³

5 When you're finished, press MULTI-ZONE CONTROL again to return to the main zone controls.

You can also press **MULTI-ZONE ON/OFF** on the front panel to switch off all output to the sub zone(s).⁴

MULTI-ZONE remote controls

Set the MULTI-ZONE operation switch to **ZONE 2** or **ZONE 3** to operate the corresponding zone.

The following table shows the possible MULTI-ZONE remote controls:

Button	What it does
	Switches on/off power in the sub zone.
INPUT SELECT	Use to select the input function in the sub zone.
Input function buttons	Use to select the input function directly (this may not work for some functions) in the sub zone.
MASTER VOLUME +/-	Use to set the listening volume in the sub zone.
MUTE	Mutes the sound or restores the sound if it has been muted (adjusting the volume also restores the sound).

Note

- 1 If the receiver is in standby, the display is dimmed, and **ZONE** and your selected sub zone(s) continue to show in the display.
- 2 The tuner cannot be tuned to more than one station at a time. Therefore, changing the station in one zone also changes the station in the other zone. Please be careful not to change stations when recording a radio broadcast.
- 3 The volume levels of the main and sub zones are independent.
- 4 • You won't be able to switch the main zone off completely unless you've switched off the MULTI-ZONE control first.
 - If you don't plan to use the MULTI-ZONE feature for a while, turn off the power in both the sub and main rooms so that this receiver is in standby.

Making an audio or a video recording

You can make an audio or a video recording from the built-in tuner, or from an audio or video source connected to the receiver (such as a CD player or TV).¹

Keep in mind you can't make a digital recording from an analog source or vice-versa, so make sure the components you are recording to/from are hooked up in the same way (see *Connecting your equipment* on page 17 for more on connections).

Since the video converter is not available when making recordings (from the video **OUT** jacks) make sure to use the same type of video cable for connecting your recorder as you used to connect your video source (the one you want to record) to this receiver. For example, you must connect your recorder using Component video if your source has also been connected using Component video.

For more information about video connections, see *Connecting an HDD/DVD recorder, VCR and other video sources* on page 30.

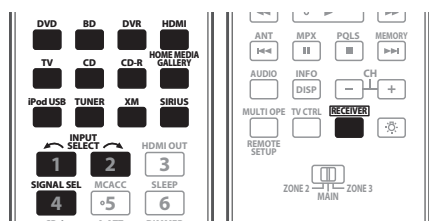

1 Select the source you want to record.

Use the input function buttons (or **INPUT SELECT**).

- If necessary, set the remote control to the receiver operation mode, then press **SIGNAL SEL** to select the input signal corresponding to the source component (see *Choosing the input signal* on page 63 for more on this).

2 Prepare the source you want to record.

Tune to the radio station, load the CD, video, DVD etc.

3 Prepare the recorder.

Insert a blank tape, MD, video etc. into the recording device and set the recording levels.

Refer to the instructions that came with the recorder if you are unsure how to do this. Most video recorders set the audio recording level automatically—check the component's instruction manual if you're unsure.

4 Start recording, then start playback of the source component.

Note

- The receiver's volume, Audio parameters (the tone controls, for example), Video parameters and surround effects have no effect on the recorded signal.
 - Some digital sources are copy-protected, and can only be recorded in analog.
 - Some video sources are copy-protected. These cannot be recorded.
- The attenuator isn't available with digital sources, or when using the Stream Direct (ANALOG DIRECT) modes.
- You can also switch off the sleep timer simply by switching off the receiver.
 - The sleep timer is valid for all zones. If any zone is on, the sleep timer continues functioning.

Reducing the level of an analog signal

The input attenuator lowers the input level of an analog signal when it's too strong. You can use this if you find that the **OVER** indicator lights often or you can hear distortion in the sound.²

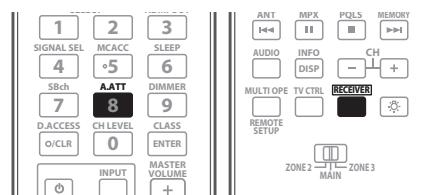

- Press **RECEIVER**, then press **A.ATT** to switch the input attenuator on or off.

Using the sleep timer

The sleep timer switches the receiver into standby after a specified amount of time so you can fall asleep without worrying about the receiver being left on all night. Use the remote control to set the sleep timer.

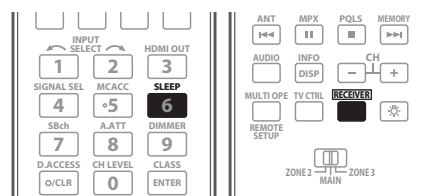

- Press **RECEIVER**, then press **SLEEP** repeatedly to set the sleep time.



- You can check the remaining sleep time at any time by pressing **SLEEP** once. Pressing repeatedly will cycle through the sleep options again.³

Dimming the display

You can choose between four brightness levels for the front panel display. Note that when selecting sources, the display automatically brightens for a few seconds.

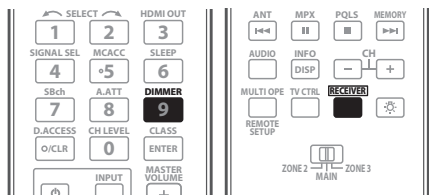

- Press **RECEIVER**, then press **DIMMER** repeatedly to change the brightness of the front panel display.

Switching the HDMI output

Set which terminal to use when outputting video and audio signals from the HDMI output terminals (**HDMI OUT ALL**, **HDMI OUT 1** or **HDMI OUT 2**).

The HDMI OUT1 terminal is compatible with the KURO LINK function.

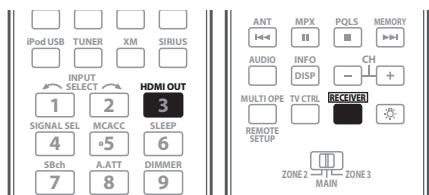

- Press **RECEIVER**, then press **HDMI OUT**. Please wait a while when **Please wait ...** is displayed. The output switches among **HDMI OUT ALL**, **HDMI OUT 1** and **HDMI OUT 2** each time the button is pressed.¹

Checking your system settings

Use the status display screen to check your current settings for features such as surround back channel processing and your current MCACC preset.

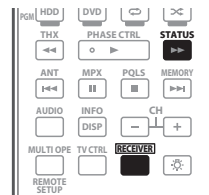

- 1 Press **RECEIVER**, then press **STATUS** to check the system settings.

These appear on the front panel display.²

The front panel display shows each of the following settings for three seconds each:

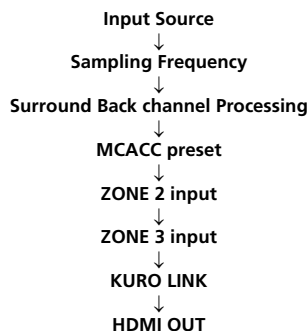

- 2 When you're finished, press **STATUS** again to switch off the display.

Note

1 • *Synchronized amp mode* on page 81 is canceled when the HDMI output is switched. If you wish to use the synchronized amp mode, switch to **HDMI OUT 1**, then select the synchronized amp mode on the flat panel TV using the flat panel TV's remote control.
 • When the power is turned off then back on after switching the HDMI output, the input is set to a setting between HDMI1 and HDMI4, or BD.
 2 If the Pure Direct mode is switched on, some settings above will show **OFF**, even though they are on.

Resetting the system

Use this procedure to reset all the receiver's settings to the factory default. Use the front panel controls to do this. Set **MULTI-ZONE** to **OFF**.

- Disconnect the iPod and USB memory device from the receiver beforehand.

1 Switch the receiver into standby.

2 While holding down ENTER on the front panel, press \odot STANDBY/ON.

The display shows **RESET ◀ NO ▶**.

3 Select 'RESET' using \leftarrow/\rightarrow , then press ENTER on the front panel.

The display shows **RESET? OK**.

4 Press ENTER to confirm.

OK appears in the display to indicate that the receiver has been reset to the factory default settings.

- Note that all settings will be saved, even if the receiver is unplugged.

Default system settings

Setting	Default
Digital Video Conversion	ON
SPEAKERS	A
Surround Back System	Normal
Speaker System	Front
	Center
	Surr
	SB
	SW
Crossover	80 Hz
X-Curve	OFF
THX Audio Setting	4 ft<
DIMMER	Brightest
Inputs	
See <i>Input function default and possible settings</i> on page 45.	
MULTI-ZONE	
ZONE 2/3 Volume Level	Variable
ZONE 2/3 Volume	-60 dB
HDMI	
HDMI Audio	Amp
HDMI output	HDMI OUT ALL
KURO LINK	ON
DSP	
Surround back channel Processing	ON
Phase Control	ON
Full Band Phase Control	OFF

Setting	Default
Sound Retriever	iPod/USB or HOME MEDIA GALLERY function
Other functions	OFF
Sound Delay	0.0 frame
Dual Mono	CH1
DRC	AUTO
SACD Gain	0 dB
LFE Attenuate	0 dB
Auto delay	OFF
Up Mix	ON
Digital Safety	OFF
Effect Level	EXT.STEREO
	Other modes
<input checked="" type="checkbox"/> PL II Music Options	Center Width
	Dimension
	Panorama
Neo:6 Options	Center Image
	Neo:6 MUSIC: 3
	Neo:6 CINEMA: 10
All Inputs	Listening Mode (2 ch)
	Listening Mode (x ch)
	Listening Mode (HP)
See also <i>Setting the Audio options</i> on page 82 for other default DSP settings.	
MCACC	
MCACC Position Memory	M1: MEMORY 1
Channel Level (M1 to M6)	0.0 dB
Speaker Distance (M1 to M6)	10.00 ft
Standing Wave (M1 to M6)	Standing Wave On/Off
	ATT of all channels/ filters
	SWch Trim
EQ Data (M1 to M6)	All channels/bands
	EQ Trim

Chapter 10:

Controlling the rest of your system

Operating multiple receivers

The remote control included with this receiver can be used to operate up to three other receivers (of the same model as this receiver) in addition to this receiver. The receiver to be operated is switched by inputting the preset code to set the remote control setting.

- Set the remote modes on the receivers before using this function (see *Remote Control Mode Setup* on page 114).

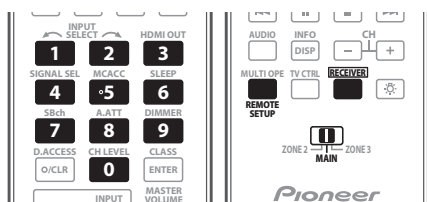

- 1 Check the operation selector switch to MAIN.
- 2 Press **RECEIVER**.
- 3 Press and hold **REMOTE SETUP**, then release it after the LED flashes twice.
- 4 Use the number buttons to enter the 5-digit preset code (see below).
 - Receiver 1: **6 1 9 3 5** (Default)
 - Receiver 2: **6 2 6 3 0**
 - Receiver 3: **6 2 6 3 1**
 - Receiver 4: **6 2 6 3 2**

The LED flashes twice when the preset code has been properly registered. When the preset code is fully input, the LED flashes once to indicate that the setting has failed.

To operate another receiver, start over from step 1 to input its preset code.

Setting the remote to control other components

Most components can be assigned to one of the input function buttons (such as **DVD** or **CD**) using the component's manufacturer preset code stored in the remote.

However, there are cases where only certain functions may be controllable after assigning the proper preset code, or the codes for the manufacturer in the remote control will not work for the model that you are using.

If you can't find a preset code that matches the component you want to control, you can still teach the remote individual commands from another remote control (see *Programming signals from other remote controls* on page 90).

Note

- You can cancel or exit any of the steps by pressing **RECEIVER**. To go back a step, press **RETURN**.
- After ten seconds of inactivity, the remote automatically exits the operation.

Selecting preset codes directly

- 1 Press the input function button for the component you want to control.¹

When assigning preset codes to **TV CONTROL**, press **TV CTRL** here.

- 2 Press and hold **REMOTE SETUP**, then release it after the LED flashes twice.

- 3 Use the number buttons to enter the 5-digit preset code.

See *Preset code list* on the separate booklet.

The LED flashes twice when the preset code has been properly registered. When the preset code is fully input, the LED flashes once to indicate that the setting has failed.

- 4 Repeat steps 1 through 3 for the other components you want to control.

To try out the remote control, switch the component on or off (into standby) by pressing **SOURCE**. If it doesn't seem to work, select the next code from the list (if there is one).

Note

¹ You can't assign **RECEIVER**, **TUNER**, **HOME MEDIA GALLERY**, **iPod USB**, **XM** or **SIRIUS**.

Programming signals from other remote controls

If the preset code for your component is not available, or the available preset codes do not operate correctly, you can program signals from the remote control of another component. This can also be used to program additional operations (buttons not covered in the presets) after assigning a preset code.¹

- 1 Press and hold **REMOTE SETUP**, then release it after the LED flashes twice.
- 2 Use the number buttons to enter **9, 7, 5**. The LED flashes twice.
- 3 Press the input function button for the component you want to control.²
- 4 Point the two remote controls towards each other, then press the button that will be doing the learning on this receiver's remote control.

The LED flashes continuously for about 5 seconds.³

- The remote controls should be 3 cm (1 inch) apart.

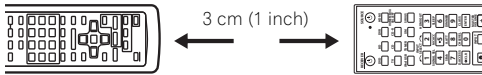

- 5 Press the corresponding button on the other remote control that is sending (teaching) the signal to this receiver's remote control.

For example, if you want to learn the playback control signal, press and hold **▶** briefly. If the LED flashes twice then turns off, this indicates that learning has been successful. If the LED only flashes once, learning has failed.⁴

Certain buttons represent operations that cannot be learned from other remote controls. The buttons available are shown below:

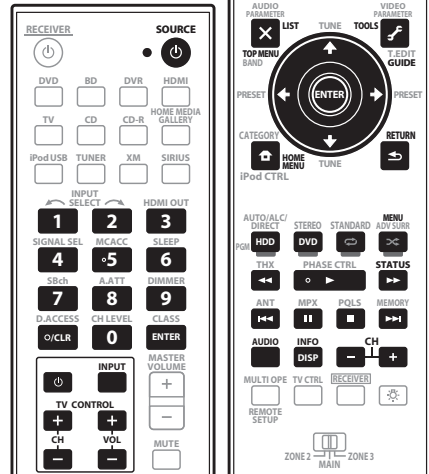

- 6 To program additional signals for the current component repeat steps 4 and 5.

To program signals for another component, exit and repeat steps 1 through 5.

Erasing the remote control button settings

This erases the buttons you have programmed and restores the button to the factory default.

- 1 Press and hold **REMOTE SETUP**, then release it after the LED flashes twice.
- 2 Use the number buttons to enter **9, 7, 6**. The LED flashes twice.

- 3 Press the input function button corresponding to the command to be erased, then press the button to be erased twice.

To erase all the settings stored at the input function buttons, press the input function button twice here.

The LED flashes twice to confirm the button has been erased.

- 4 Repeat step 3 to erase other buttons.

Note

¹ The remote can store about 200 preset codes (this has been tested with codes of Pioneer format only).

² You can't assign **TUNER**, **HOME MEDIA GALLERY**, **iPod USB**, **XM** or **SIRIUS**.

³ The **TV CONTROL** buttons (**TV**, **TV VOL +/-**, **TV CH +/-** and **INPUT**) can only be learned after the **TV CTRL** is pressed.

⁴ The learning mode is cancelled if no remote control signal is received within 5 seconds.

Note that interference from TVs or other devices will sometimes result in the remote control learning the wrong signal.

- Some commands from other remote controls cannot be learned, but in most cases the remotes just need to be moved closer together or farther apart.

- If the LED flashes once, it means the memory is full. See *Erasing the remote control button settings* above to erase a programmed button you're not using to free up more memory (note that some signals may take more memory than others).

Multi Operation and System Off

The Multi Operation feature allows you to program a series of up to 32 commands for the components in your system. For example, you could turn on your TV, turn on your DVD player and start playing the loaded DVD using only two buttons on the remote control.

Similar to multi operations, System Off allows you to use one button to stop and switch off a series of components in your system at the same time. The System Off feature allows you to program a series of 5 commands for the components in your system.¹

Programming a multi-operation

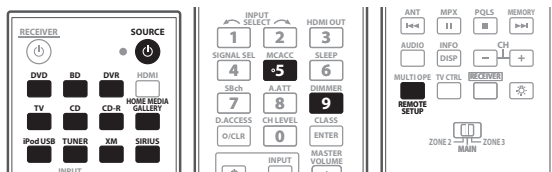

1 Press and hold REMOTE SETUP, then release it after the LED flashes twice.

2 Use the number buttons to enter 9, 9, 5.
The LED flashes twice.

If you selected System Off, go to step 3.

If you selected Multi Operation, go to step 4.

3 Press the SOURCE button.

4 Press the input function button for the component whose command you want to input, then press the button for the command you want to input.

For example, if you want to start the sequence by switching on your DVD player, press **DVD**, then press **SOURCE**.

The following remote control commands can be selected:

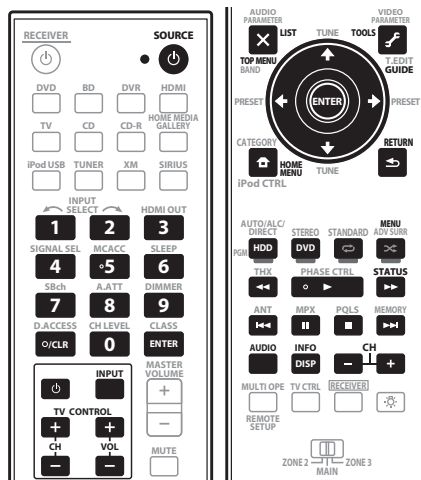

• You don't need to program the receiver to switch on or off. This is done automatically.

With Pioneer components, you don't need to:

- program the power to switch off in a shutdown sequence (except DVD recorders);

These take priority in multi operations (not shutdown).

5 Repeat step 4 to program a sequence.

- A space of 250 ms can be input between commands by pressing **REMOTE SETUP** between commands.
- If the LED does not light when the input function button is pressed, this indicates that there is no command for that input function.

Using multi operations

You can start multi operations with the receiver switched on, or in standby.

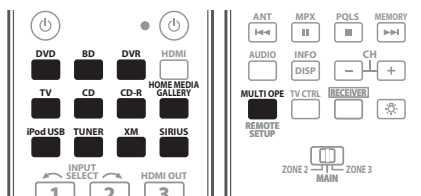

1 Press MULTI OPE.

2 Press an input function button that has been set up with a multi operation.

The receiver switches on (if it was in standby) and the programmed multi operation is performed automatically.

Note

- Before Multi Operation and System Off will work correctly, you must setup the remote to work with your TV and other components (see *Operating multiple receivers* on page 89 for more on this).
- Some units may take some time to power up, in which case multiple operations may not be possible.
- Power on and off commands only work with components that have a standby mode.

Using System off

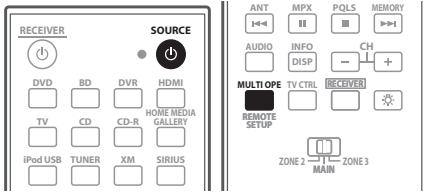

1 Press **MULTI OPE**.

2 Press **SOURCE**.

The command sequence you programmed will run, then all Pioneer components will switch off¹, followed by this receiver.

Resetting the remote control presets

This will erase all preset remote control preset codes and programmed buttons.²

1 Check the operation selector switch to **MAIN**.

2 Press **RECEIVER**.

3 Press and hold **REMOTE SETUP**, then release it after the LED flashes twice.

4 Use the number buttons to enter **9, 8, 1**.

The LED flashes four times to indicate that the resetting is completed.

Default preset codes

Input function button	Preset code
DVD	3 1 5 7 1
BD	3 2 4 4 2
DVR	2 2 3 0 6
HDMI	3 2 4 4 2
TV	1 4 0 0 1
CD	7 0 4 6 8
CD-R	7 1 0 8 7
TV CTRL	1 4 0 0 1
RECEIVER	6 1 9 3 5

Controls the components

This remote control can control components after entering the proper codes (see *Setting the remote to control other components* on page 89 for more on this). Use the input function buttons to select the component.

- The **TV CONTROL** buttons on the remote control are dedicated to control the TV assigned to the **TV CTRL** button. If you have two TVs, assign the main TV to the **TV CTRL** button.

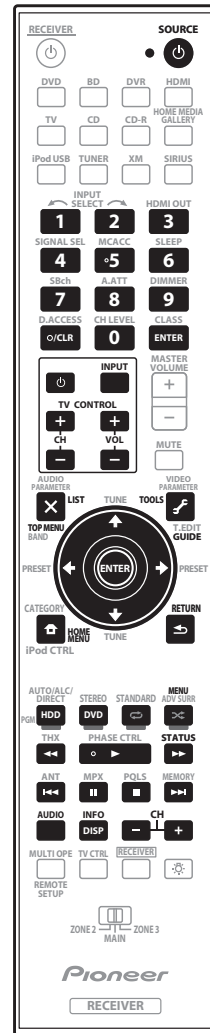

Note

¹ In order to avoid accidentally switching off a DVD recorder that is currently recording, no DVD recorder power off codes are sent.

² When *Selecting preset codes directly* on page 89 are set, all the signals learned in the input function buttons are cleared. This function is convenient when you want to reset some but not all of input function buttons.

Button(s)	TV	TV (Monitor)	BD/DVD	HDD/DVR	VCR	SAT/CATV
SOURCE	POWER ON/OFF	POWER ON/OFF	POWER ON/OFF	POWER ON/OFF	POWER ON/OFF	POWER ON/OFF
Number buttons	<i>numerics</i>	<i>numerics</i>	<i>numerics</i>	<i>numerics</i>	<i>numerics</i>	<i>numerics</i>
• (dot)	• (dot)	KURO LINK	CLEAR	+	CLEAR	*
ENTER (CLASS)	CH ENTER	CH ENTER	ENTER	CLEAR	–	ENTER
	EXIT/INFO	EXIT	TOP MENU	TOP MENU/ DISC NAVI	–	LIST
	TOOLS/GUIDE	USER MENU	TOOLS ^a	GUIDE	–	GUIDE
					–	
ENTER	ENTER	ENTER	ENTER	ENTER	–	ENTER
	HOME MENU	HOME MENU	HOME MENU	HOME MENU	–	HOME
	RETURN	RETURN	RETURN	RETURN	–	RETURN
HDD (Red)	<i>Red</i>	<i>Red</i>	–	HDD	–	<i>A/Red</i>
DVD (Green)	<i>Green</i>	<i>Green</i>	–	DVD	–	<i>B/Green</i>
(Yellow)	<i>Yellow</i>	<i>Yellow</i>	–	VCR	–	<i>C/Yellow</i>
(Blue)	<i>Blue</i>	<i>Blue</i>	MENU	MENU	–	MENU/ <i>Blue</i>
	–	–				E/
	–	AUTO SETUP				
	–	FREEZE				
	–	–				D/
	–	–				
	ANT	AV SELECTION				
	–	SCREEN SIZE				
AUDIO	AUDIO	AUDIO	AUDIO	AUDIO	AUDIO	AUDIO
DISP	DISPLAY	DISPLAY	DISPLAY	DISPLAY	–	DISPLAY/INFO
CH +/-	CH +/-	CH +/-	OUTPUT RESOLUTION +/- ^a	CH +/-	CH +/-	CH +/-
	–	–	–	–	–	RECORD

a.Controls for BD.

Button(s)	LD	CD/CD-R/SACD	MD/DAT	TAPE
SOURCE	POWER ON/OFF	POWER ON/OFF	POWER ON/OFF	POWER ON/OFF
Number buttons	<i>numerics</i>	<i>numerics</i>	<i>numerics</i>	–
• (dot)	+10	>10/CLEAR	CLEAR ^b	CLEAR
ENTER (CLASS)	ENTER	DISC/ENTER	OPEN/CLOSE ^b	ENTER
	TOP MENU	–	–	MS←
	–	LEGATO LINK ^a	–	MS→
		–	–	
ENTER	ENTER	–	–	
	–	SACD SETUP ^a	–	–
	RETURN	–	–	–
HDD (Red)	–	PROGRAM	–	–
(Yellow)	–	REPEAT	–	–
(Blue)	–	SHUFFLE	–	–
AUDIO	AUDIO	PURE AUDIO ^a	–	–
DISP	DISPLAY/INFO	TIME ^a	–	–

a. Controls for SACD.

b. Controls for MD.

Button(s)	TV (Projector)
SOURCE	POWER ON
1	MOVIE
2	STANDARD
3	DYNAMIC
4	USER1
5	USER2
6	USER3
7	COLOR+
8	SHARP+
9	GAMMA
0	COLOR–
• (dot)	SHARP–
ENTER (CLASS)	COLOR TEMP
	EXIT
	INFO
ENTER	ENTER
	TEST
	HIDE
	MENU
	HDMI1
	HDMI2
	COMP.
	VIDEO
	S-VIDEO
	BRIGHT–
	BRIGHT+
AUDIO	POWER OFF
DISP	ASPECT
CH +/-	CONTRAST+/-

Chapter 11: The Advanced MCACC menu

Making receiver settings from the Advanced MCACC menu

The Advanced MCACC (Multi Channel Acoustic Calibration) system was developed in Pioneer's laboratories with the aim of making it possible for home users to perform adjustments of the same level as in a studio easily and with high precision. The acoustic characteristics of the listening environment are measured and the frequency response is calibrated accordingly to allow high precision, automatic analysis and optimal calibration of the sound field to bring it closer to a studio environment than ever before. Furthermore, while it was previously difficult to eliminate standing waves, this receiver is equipped with a standing wave control function using a unique process to perform acoustic analysis and reduce their influence.

This section describes how to calibrate the sound field automatically and fine-adjust the sound field data manually.

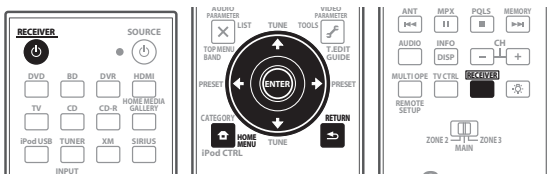

1 Switch on the receiver and your TV.

Use **RECEIVER** to switch on.¹

- If headphones are connected to the receiver, disconnect them.

2 Press **RECEIVER**, then press **HOME MENU**.²

A Graphical User Interface (GUI) screen appears on your TV. Use **↑/↓/←/→** and **ENTER** to navigate through the screens and select menu items. Press **RETURN** to confirm and exit the current menu.

- Press **HOME MENU** at any time to exit the **HOME MENU**.
- The screen saver will automatically appear after five minutes of inactivity.

3 Select 'Advanced MCACC' from the HOME MENU, then press **ENTER**.

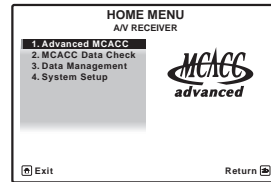

4 Select the setting you want to adjust.

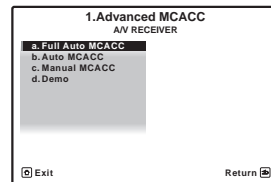

- **Full Auto MCACC** – See *Automatically setting up for surround sound (Auto MCACC & Full Band Phase Control)* on page 42 for a quick and effective automatic surround setup.
- **Auto MCACC** – See *Automatic MCACC (Expert)* on page 96 for a more detailed MCACC setup. In addition, the Full Band Phase Control function calibrates the frequency-phase characteristics of the connected speakers.
- **Manual MCACC** – Fine-tunes your speaker settings and customize the Acoustic Calibration EQ (see *Manual MCACC setup* on page 98).
- **Demo** – No settings are saved and no errors occur. When the speakers are connected to this receiver, the test tone is output repeatedly. Press **RETURN** to cancel the test tone.

Note

¹ Make sure not to switch off the power when using the **HOME MENU**.

² You can't use the **HOME MENU** when the HOME MEDIA GALLERY, XM, SIRIUS or iPod/USB input function is selected (in either the main or sub zone). When you set **ZONE 2**, **ZONE 3** or **ZONE 2&3** to **ON** (page 85), you can't use the **HOME MENU**.

Automatic MCACC (Expert)

If your setup requires more detailed settings than those provided in *Automatically setting up for surround sound (Auto MCACC & Full Band Phase Control)* on page 42, you can customize your setup options below. You can calibrate your system differently for up to six different MCACC presets¹, which are useful if you have different listening positions depending on the type of source (for example, watching movies from a sofa, or playing a video game close to the TV).²

Important

- Make sure the microphone/speakers are not moved during the Auto MCACC Setup.
- Using the Auto MCACC Setup will overwrite any existing settings for the MCACC preset you select.³

CAUTION

- The test tones used in the Auto MCACC Setup are output at high volume.

THX®

THX is a trademark of THX Ltd., which may be registered in some jurisdictions. All rights reserved.

1 Select 'Auto MCACC' from the Advanced MCACC menu, then press ENTER.

If the **Advanced MCACC** screen is not displayed, refer to *Making receiver settings from the Advanced MCACC menu* on page 95.

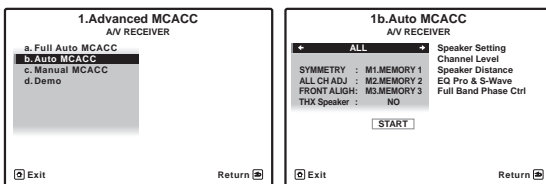

2 Select the parameters you want to set.

Use **↑/↓** to select the item, then use **←/→** to set.

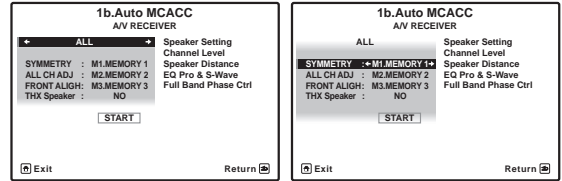

- **Auto MCACC** – The default is **ALL** (recommended), but you can limit the system calibration to only one setting (to save time) if you want.⁴ The available options are **ALL**, **Keep SP System**,⁵ **Speaker Setting**, **Channel Level**, **Speaker Distance**, **EQ Pro & S-Wave** and **Full Band Phase Ctrl**.
- **EQ Type** (*only available when the Auto MCACC Menu above is EQ Pro & S-Wave*) – This determines how the frequency balance is adjusted.

After a single calibration is performed, each of the following three correction curves can be stored separately in the MCACC memory. **SYMMETRY** (default) implements symmetric correction for each pair of left and right speakers to flatten the frequency-amplitude characteristics. **ALL CH ADJ** is a 'flat' setting where all the speakers are set individually so no special weighting is given to any one channel. **FRONT ALIGN**⁶ sets all speakers in accordance with the front speaker settings (no equalization is applied to the front left and right channels).

- **THX Speaker** (*only available when the Auto MCACC Menu above is ALL or Speaker Setting*) – Select **YES** if you are using THX speakers (set all speakers to **SMALL**), otherwise leave it set to **NO**.
- **STAND.WAVE Multi-Point** (*only available when the Auto MCACC Menu above is EQ Pro & S-Wave*) – In addition to measurements at the listening position, you can use two more reference points for which test tones will be analyzed for standing waves. This is useful if you want to get a balanced 'flat' calibration for several seating positions in your listening area.⁷ Place the microphone at the reference point indicated on-screen and note *the last microphone placement will be at your main listening position*:

Note

- These are stored in memory and referred to as **MEMORY1** to **MEMORY6** until you rename them in *Data Management* on page 106.
- You may also want to have separate calibration settings for the same listening position, depending on how you're using your system.
- Except in cases where you are only adjusting one parameter (i.e. channel level) from the **Auto MCACC** menu (step 2).
- The **EQ Pro & S-Wave** measurement is also taken when **Keep SP System** or **EQ Pro & S-Wave** is selected. See *Acoustic Calibration EQ Professional* on page 101 for more on this.
 - Either effect of Acoustic Calibration EQ Professional and Standing Wave can be switched on and off in the respective MCACC preset. For details, see *Setting the Audio options* on page 82.
- The **Keep SP System** option allows you to calibrate your system while leaving your current speaker setting (page 109) unchanged.
- If you selected **ALL** as your **Auto MCACC** menu, you can specify the MCACC preset where you want to save the **ALL CH ADJ** and **FRONT ALIGN** settings.
- Switch the **Multi-Point** setting **NO** if you only use one listening position.

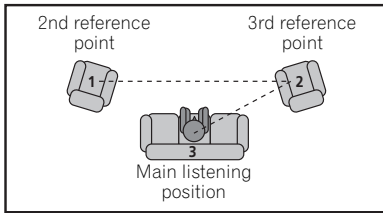

3 Connect the microphone to the MCACC SETUP MIC jack on the front panel.

Make sure there are no obstacles between the speakers and the microphone.

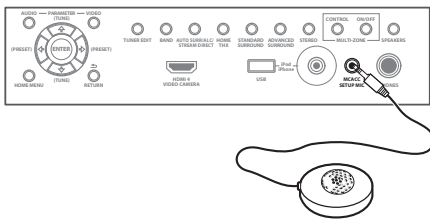

If you have a tripod, use it to place the microphone so that it's about ear level at your normal listening position. If you do not have a tripod, use some other object to install the microphone.¹

4 When you're finished settings the options, select **START** then press **ENTER**.

5 Follow the instructions on-screen.

- Make sure the microphone is connected.
- If you're using a subwoofer, it is automatically detected every time you switch on the system. Make sure it is on and the volume is turned up.
- See *Problems when using the Auto MCACC Setup* on page 44 for notes regarding high background noise levels and other possible interference.

6 Wait for the Auto MCACC Setup to finish outputting test tones.

A progress report is displayed on-screen while the receiver outputs test tones to determine the speakers present in your setup. Try to be as quiet as possible while it's doing this.

- Do not adjust the volume during the test tones. This may result in incorrect speaker settings.

- With error messages (such as **Too much ambient noise!** or **Check microphone**) select **RETRY** after checking for ambient noise (see *Problems when using the Auto MCACC Setup* on page 44) and verifying the mic connection. If there doesn't seem to be a problem, you can simply select **GO NEXT** and continue.

7 If necessary, confirm the speaker configuration in the GUI screen.²

The configuration shown on-screen should reflect the actual speakers you have.

If no operations are performed for 10 seconds while the speaker configuration check screen is being displayed, the Auto MCACC Setup will resume automatically. In this case, you don't need to select 'OK' and press **ENTER** in step 8.

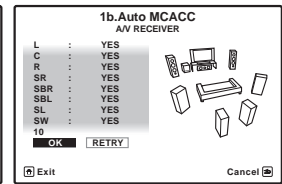
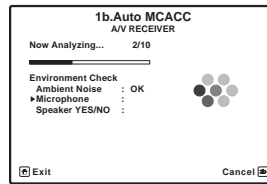

- If you see an **ERR** message (or the speaker configuration displayed isn't correct), there may be a problem with the speaker connection. If selecting **RETRY** doesn't work, turn off the power and check the speaker connections. If there doesn't seem to be a problem, you can simply use **↑/↓** to select the speaker and **←/→** to change the setting and continue.
- If **Reverse Phase** is displayed, the speaker's wiring (+ and -) may be inverted. Check the speaker connections.³
 - If the connections were wrong, turn off the power, disconnect the power cord, then reconnect properly. After this, perform the Full Auto MCACC procedure again.
 - If the connections were right, select **GO NEXT** and continue.

Note

1 It may not be possible to measure correctly if the microphone is placed on a table, sofa, etc.
 2 This screen is only shown if you selected **ALL** or **Speaker Setting** from the **Auto MCACC** menu.
 3 If the speaker is not pointed to the microphone (listening position) or when using speakers that affect the phase (dipole speakers, reflective speakers, etc.), **Reverse Phase** may be displayed even if the speakers are properly connected.

8 Make sure 'OK' is selected, then press ENTER.

A progress report is displayed on-screen while the receiver outputs more test tones to determine the optimum receiver settings for channel level, speaker distance, and Acoustic Calibration EQ.

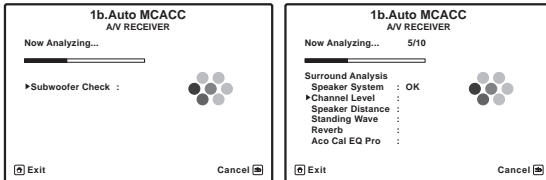

Again, try to be as quiet as possible while this is happening. It may take 3 to 7 minutes.

- If you selected a **STAND.WAVE Multi-Point** setup (in step 2), you will be asked to place the mic at the 2nd and 3rd reference points before finally placing it at your main listening position.

9 The Auto MCACC Setup procedure is completed and the Advanced MCACC menu reappears automatically.

The settings made in the Auto MCACC Setup should give you excellent surround sound from your system, but it is also possible to adjust these settings manually using the **Manual MCACC** setup menu (starting below) or **Manual SP Setup** menu (starting on page 108).¹

You can also choose to view the settings by selecting individual parameters from the **MCACC Data Check** screen:

- **Speaker Setting** – The size and number of speakers you've connected (see page 109 for more on this)
- **Channel Level** – The overall balance of your speaker system (see page 99 or 110 for more on this)
- **Speaker Distance** – The distance of your speakers from the listening position (see page 100 or 111 for more on this)²
- **Standing Wave** – Filter settings to control lower 'boomy' frequencies (see page 100 for more on this)
- **Acoustic Cal EQ** – Adjustments to the frequency balance of your speaker system based on the acoustic characteristics of your room (see page 101 for more on this)
- **Group Delay** – The original characteristics of group delay of the speakers calibrated and the targeted characteristics can be displayed graphically (see *Group Delay* on page 105 for more on this).

- **Output PC** – The data transfer mode with the connected computer is set. The graphs of the reverb characteristics and group delay characteristics before and after calibration and the various MCACC parameters can be checked (see *Output PC* on page 106 for more on this).

Press **RETURN** after you have finished checking each screen. When you're finished, select **RETURN** to go back to the **HOME MENU**.

Be sure to disconnect the microphone from this receiver upon completion of the Auto MCACC Setup.

Manual MCACC setup

You can use the settings in the **Manual MCACC** setup menu to make detailed adjustments when you're more familiar with the system. Before making these settings, you should have already completed *Automatically setting up for surround sound (Auto MCACC & Full Band Phase Control)* on page 42.

You only need to make these settings once (unless you change the placement of your current speaker system or add new speakers).

⚠ CAUTION

- The test tones used in the **Manual MCACC** setup are output at high volume.

👉 Important

- You will need to first specify the MCACC preset you want to adjust by pressing **MCACC** before pressing **HOME MENU** (step 2 in *Making receiver settings from the Advanced MCACC menu* on page 95).
- For some of the settings below, you'll have to connect the setup microphone to the front panel and place it about ear level at your normal listening position. Press **HOME MENU** to display the **HOME MENU** before you connect the microphone to this receiver. If the microphone is connected while the **HOME MENU** is not being displayed, the display will change to the **Full Auto MCACC** under **Advanced MCACC**.
- See *Problems when using the Auto MCACC Setup* on page 44 for notes regarding high background noise levels and other possible interference.
- If you're using a subwoofer, switch it on and turn up the volume to the middle position.

📌 Note

- 1 Depending on the characteristics of your room, sometimes identical speakers with cone sizes of around 12 cm (5 inches) will end up with different size settings. You can correct the setting manually using the *Manual speaker setup* on page 108.
 - The subwoofer distance setting may be farther than the actual distance from the listening position. This setting should be accurate (taking delay and room characteristics into account) and generally does not need to be changed.
 - If Auto MCACC Setup measurement results are incorrect due to the interaction of the speakers and viewing environment, we recommend adjusting the settings manually.
- 2 Since the distance measurements have been set according to the sound characteristics of your speakers, there are cases where (for optimal surround sound) the actual distance may differ from the speaker distance setting.

1 Select 'Manual MCACC' from the Advanced MCACC menu.

See *Making receiver settings from the Advanced MCACC menu* on page 95 if you're not already at this screen.

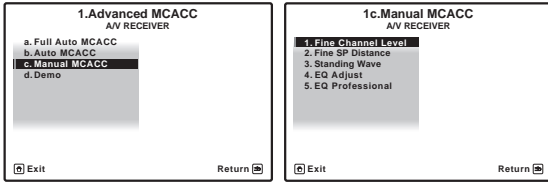

2 Select the setting you want to adjust.

If you're doing this for the first time, you might want to make these settings in order.

- **Fine Channel Level** – Make fine adjustments to the overall balance of your speaker system (see *Fine Channel Level* below).
- **Fine SP Distance** – Make precise delay settings for your speaker system (see *Fine Speaker Distance* on page 100).
- **Standing Wave** – Control overly resonant low frequencies in your listening room (see *Standing Wave* on page 100).

The last two settings are specifically for customizing the parameters explained in *Acoustic Calibration EQ Adjust* on page 101:

- **EQ Adjust** – Manually adjust the frequency balance of your speaker system while listening to test tones (see *Acoustic Calibration EQ Adjust* on page 101).
- **EQ Professional** – Calibrate your system based on the direct sound coming from the speakers and make detailed settings according to your room's reverb characteristics (see *Acoustic Calibration EQ Professional* on page 101).

Fine Channel Level

- Default setting: **0.0dB** (all channels)

You can achieve better surround sound by properly adjusting the overall balance of your speaker system. You can adjust the Channel Level of each speaker in 0.5 dB increments. The following setting can help you make detailed adjustments that you may not achieve using the *Manual speaker setup* on page 108.

1 Select 'Fine Channel Level' from the Manual MCACC setup menu.

The volume increases to the 0.0 dB reference level.

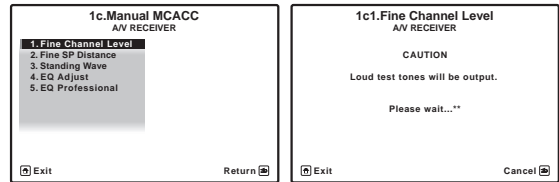

2 Adjust the level of the left channel.

This will be the reference speaker level, so you may want to keep the level around **0.0dB** so that you'll have plenty of room to adjust the other speaker levels.

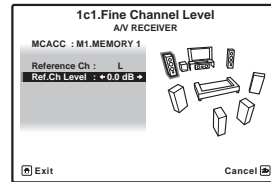

- After pressing **ENTER**, test tones will be output.

3 Select each channel in turn and adjust the levels (+/-10.0 dB) as necessary.

Use **←/→** to adjust the volume of the speaker you selected to match the reference speaker. When it sounds like both tones are the same volume, press **↓** to confirm and continue to the next channel.

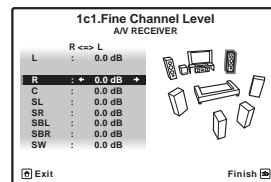

- For comparison purposes, the reference speaker will change depending on which speaker you select.
- If you want to go back and adjust a channel, simply use **↑/↓** to select it.

4 When you're finished, press RETURN.

You will return to the **Manual MCACC** setup menu.

Fine Speaker Distance

- Default setting: **10'00"** (all speakers)

For proper sound depth and separation with your system, it is necessary to add a slight bit of delay to some speakers so that all sounds will arrive at the listening position at the same time. You can adjust the distance of each speaker in $1/2$ inch increments. The following setting can help you make detailed adjustments that you may not achieve using the *Manual speaker setup* on page 108.

1 Select 'Fine SP Distance' from the Manual MCACC setup menu.

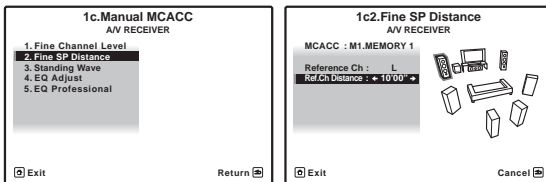

2 Adjust the distance of the left channel from the listening position.

3 Select each channel in turn and adjust the distance as necessary.

Use \leftarrow/\rightarrow to adjust the delay of the speaker you selected to match the reference speaker. The delay is measured in terms of speaker distance from **0'00-1/2"** to **45'00"**.

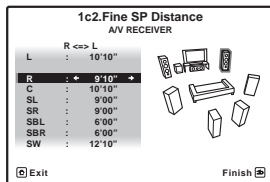

Listen to the reference speaker and use it to measure the target channel. From the listening position, face the two speakers with your arms outstretched pointing at each speaker. Try to make the two tones sound as if they are arriving simultaneously at a position slightly in front of you and between your arm span.¹

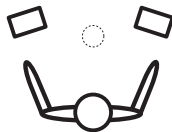

Note

- If you can't seem to achieve this by adjusting the distance setting, you may need to change the angle of your speakers very slightly.
- For better audibility, the subwoofer emits a continuous test tone (oscillating pulses are heard from your other speakers). Note that it may be difficult to compare this tone with the other speakers in your setup (depending on the low frequency response of the reference speaker).
- You can switch on or off the Standing Wave in the **AUDIO PARAMETER** menu. See *Setting the Audio options* on page 82 for more on this.
- Since they will be overwritten, you may want to save the standing wave settings made with the Auto MCACC Setup to another MCACC preset.
 - Standing Wave control filter settings cannot be changed during playback of sources using the HDMI connection.
 - When **Standing Wave** is selected for an MCACC preset memory where **STAND.WAVE** is set to **OFF** in the **AUDIO PARAMETER**, **STAND.WAVE ON** is automatically selected.

When it sounds like the delay settings are matched up, press \downarrow to confirm and continue to the next channel.

- For comparison purposes, the reference speaker will change depending on which speaker you select.
- If you want to go back and adjust a channel, simply use \uparrow/\downarrow to select it.

4 When you're finished, press RETURN.

You will return to the **Manual MCACC** setup menu.

Standing Wave

- Default setting: **ON²/ATT 0.0dB** (all filters)

Acoustic standing waves occur when, under certain conditions, sound waves from your speaker system resonate mutually with sound waves reflected off the walls in your listening area. This can have a negative effect on the overall sound, especially at certain lower frequencies. Depending on speaker placement, your listening position, and ultimately the shape of your room, it results in an overly resonant ('boomy') sound. The Standing Wave Control uses filters to reduce the effect of overly resonant sounds in your listening area. During playback of a source, you can customize the filters used for Standing Wave Control for each of your MCACC presets.³

1 Select 'Standing Wave' from the Manual MCACC setup menu.

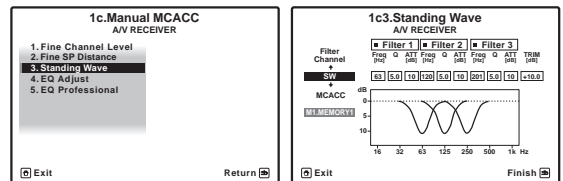

2 Adjust the parameters for the Standing Wave Control.

- **Filter Channel** – Select the channel to which you will apply the filter(s): **MAIN** (all except center channel and subwoofer), **Center** or **SW** (subwoofer).
- **TRIM** (only available when the filter channel above is **SW**) – Adjust the subwoofer channel level (to compensate for the difference in output post-filter).

- **Freq/Q/ATT** – These are the filter parameters where **Freq** represents the frequency you will be targeting and **Q** is the bandwidth (the higher the Q, the narrower the bandwidth, or range) of the attenuation (**ATT**, the amount of reduction to the targeted frequency).

3 When you're finished, press RETURN.
You will return to the **Manual MCACC** setup menu.

Acoustic Calibration EQ Adjust

- Default setting: **ON¹/0.0dB** (all channels/bands)

Acoustic Calibration Equalization is a kind of room equalizer for your speakers (excluding the subwoofer). It works by measuring the acoustic characteristics of your room and neutralizing the ambient characteristics that can color the original source material (providing a 'flat' equalization setting). If you're not satisfied with the adjustment provided in *Automatically setting up for surround sound (Auto MCACC & Full Band Phase Control)* on page 42 or *Automatic MCACC (Expert)* on page 96, you can also adjust these settings manually to get a frequency balance that suits your tastes.²

1 Select 'EQ Adjust' from the Manual MCACC setup menu.

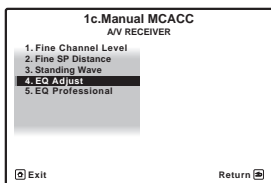

2 Select the channel(s) you want and adjust to your liking.

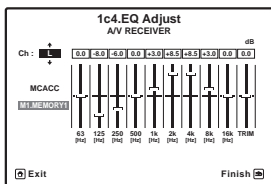

Use **↑/↓** to select the channel.

Use **←/→** to select the frequency and **↑/↓** to boost or cut the EQ. When you're finished, go back to the top of the screen and press **←** to return to **Ch**, then use **↑/↓** to select the channel.

- The **OVER!** indicator shows in the display if the frequency adjustment is too drastic and might distort. If this happens, bring the level down until **OVER!** disappears from the display.

Tip

- Changing the frequency curve of one channel too drastically will affect the overall balance. If the speaker balance seems uneven, you can raise or lower channel levels using test tones with the **TRIM** feature. Use **↑/↓** to select **TRIM**, then use **←/→** to raise or lower the channel level for the current speaker.

3 When you're finished, press RETURN.
You will return to the **Manual MCACC** setup menu.

Acoustic Calibration EQ Professional

This setup minimizes the unwanted effects of room reverberation by allowing you to calibrate your system based on the direct sound coming from the speakers. It can also provide you with a graphical output of the frequency response of your room.³

How to use Acoustic Calibration EQ Professional

If you find that lower frequencies seem overly reverberant in your listening room (i.e. it sounds 'boomy'), or that different channels seem to exhibit different reverb characteristics, select **EQ Pro & S-Wave** (or **ALL**) for the **Auto MCACC** setting in *Automatic MCACC (Expert)* on page 96 to calibrate the room automatically. This should provide a balanced calibration that suits the characteristics of your listening room.

If you still aren't satisfied with the results, the manual **Advanced EQ Setup** (below) provides a more customized calibration of your system using the direct sound of the speakers. This is done with the help of a graphical output that can be displayed on-screen, or using a computer (with software available from Pioneer — see *Output PC* on page 106).

How to interpret the graphical output

The graph shows decibels on the vertical axis and time (in milliseconds) on the horizontal axis. A straight line indicates a flat-response room (no reverb), whereas a sloping line indicates the presence of reverberation when outputting test tones. The sloping line will eventually flatten out when the reverberant sound stabilizes (this usually takes about 100 ms or so).

Note

- 1 You can switch on or off the Acoustic Calibration EQ feature in the **AUDIO PARAMETER** menu. See *Setting the Audio options* on page 82 for more on this.
- 2 When **EQ Adjust** is selected for an MCACC preset memory where **EQ** is set to **OFF** in the **AUDIO PARAMETER**, **EQ ON** is automatically selected.
- 3 This system allows you to customize your system calibration with the help of a graphical output that can be displayed on-screen, or using a computer (with software available from Pioneer—see *Output PC* on page 106 for more on this).

By analyzing the graph, you should be able to see how your room is responding to certain frequencies. Differences in channel level and speaker distance are taken into account automatically (compensation is provided for comparison purposes), and the frequency measurements can be examined both with and without the equalization performed by this receiver.¹

Setting Acoustic Calibration EQ Professional according to your room characteristics

Using the manual setup, you can set the time period at which the frequency response is analyzed, pinpointing the time that is best for system calibration with your particular room characteristics.

The graph below shows the difference between conventional acoustic calibration and professional calibration (the gray circle indicates the point where the microphone captures sound during frequency analysis).

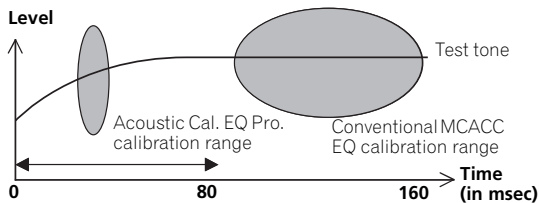

As soon as audio is output from your speaker system, it is influenced by room characteristics, such as walls, furniture, and the dimensions of the room. The sooner the frequency analysis, the less it is influenced by the room. We recommend an earlier time setting of **30-50ms** to compensate for two major factors that will influence the sound of most rooms:

- **Reverberance of high vs. low frequencies** – Depending on your room, you may find that lower frequencies seem overly reverberant compared to higher frequencies (i.e. your room sounds 'boomy'). This may result in a skewed frequency analysis if the measurement is done too late.

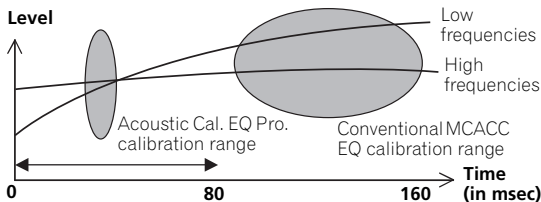

Note

- ¹ Note that due to an effect known as 'group delay', lower frequencies will take longer to be generated than higher frequencies (this is most obvious when comparing the frequencies at 0 ms). This initial slope is not a problem (i.e. excessive reverb) with your listening room.
- ² If the **Reverb View** procedure is performed after the *Automatically setting up for surround sound (Auto MCACC & Full Band Phase Control)* on page 42 or **Reverb Measurement** operation, depending on the standing wave control setting, differences may appear on the reverb graph. With the Auto MCACC function, the reverberations are measured with the standing waves controlled, so the reverb characteristics graph shows the characteristics with the effect of the standing waves eliminated. By contrast, the **Reverb Measurement** function measures the reverberations without controlling the standing waves, so the graph indicates the reverb characteristics including the effect of the standing waves. If you wish to check the reverb characteristics of the room itself (with the standing waves as such), we recommend using the **Reverb Measurement** function.

- **Reverb characteristics for different channels** – Reverb characteristics can be somewhat different for each channel. Since this difference increases as the sound is influenced by the various room characteristics, it is often better to capture a frequency analysis early on for smoother mixing of channel frequencies/sounds.

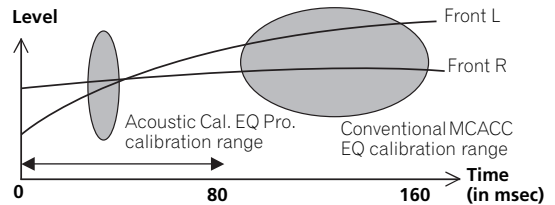

If your room isn't affected by the factors above, it is often not necessary to make a **30-50ms** setting. Later time settings may provide a more detailed sound experience with your speaker system. It is best to try and see what works best for your particular room.

Note that changing the room (for example, moving furniture or paintings) will affect the calibration results. In such cases, you should recalibrate your system.

Using Acoustic Calibration EQ Professional

- 1 Select '**EQ Professional**', then press **ENTER**.

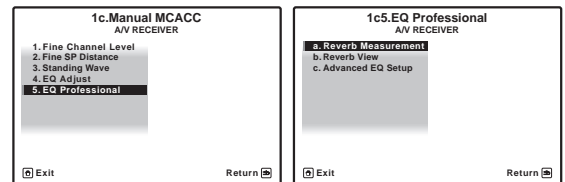

- 2 Select an option and press **ENTER**.

- **Reverb Measurement** – Use this to measure the reverb characteristics of your room (for graphical output using a PC, see *Connecting a PC for Advanced MCACC output* on page 38 to connect an RS-232C cable before selecting this option).
- **Reverb View** – You can check the reverb measurements made for specified frequency ranges in each channel.²

- **Advanced EQ Setup** – Use this to select the time period that will be used for frequency adjustment and calibration, based on the reverb measurement of your listening area. Note that customizing system calibration using this setup will alter the settings you made in *Automatically setting up for surround sound (Auto MCACC & Full Band Phase Control)* on page 42 or *Automatic MCACC (Expert)* on page 96 and is not necessary if you're satisfied with these settings.

3 If you selected 'Reverb Measurement', select EQ ON or OFF, and then START.

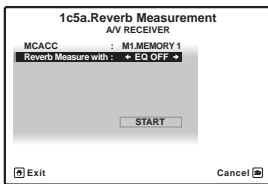

The following options determine how the reverb characteristics of your listening area are displayed in **Reverb View** and **Output PC** (see *Connecting a PC for Advanced MCACC output* on page 38):

- **EQ OFF** – You will see the reverb characteristics of your listening area *without* the equalization performed by this receiver (before calibration).
- **EQ ON** – You will see the reverb characteristics of your listening area *with* the equalization performed by this receiver (after calibration).¹ Note that the EQ response may not appear entirely flat due to adjustments necessary for your listening area.²

When the reverb measurement is finished, you can select **Reverb View** to see the results on-screen. See *Professional Calibration EQ graphical output* on page 120 for troubleshooting information.

4 If you selected 'Reverb View', you can check the reverb characteristics for each channel. Press RETURN when you're done.

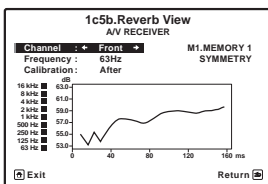

The reverb characteristics are displayed when the **Full Auto MCACC** or **Reverb Measurement** measurements are conducted.³

Use **←/→** to select the channel, frequency and calibration setting you want to check. Use **↑/↓** to go back and forth between the three. The reverb characteristics graph before and after EQ calibration can be displayed by selecting **Calibration : Before / After**.⁴ Note that the markers on the vertical axis indicate decibels in 2 dB steps.

5 If 'Advanced EQ Setup' is selected, select the MCACC memory to be stored, then enter the desired time setting for calibration, and then select START.

Based on the reverb measurement above, you can choose the time period that will be used for the final frequency adjustment and calibration. Even though you can make this setting without reverb measurement, it is best to use the measurement results as a reference for your time setting. For an optimal system calibration based on the direct sound coming from the speakers, we recommend using the **30-50ms** setting.

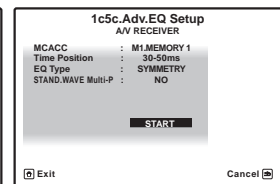
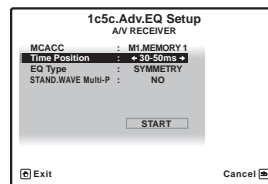

Use **←/→** to select the setting. Use **↑/↓** to switch between them.

Select the setting from the following time periods (in milliseconds): **0-20ms, 10-30ms, 20-40ms, 30-50ms, 40-60ms, 50-70ms** and **60-80ms**. This setting will be applied to all channels during calibration.

When you're finished, select **START**. It will take about 2 to 4 minutes for the calibration to finish.

After the Acoustic Calibration Equalization is set, you are given the option to check the settings on-screen.

Note

- 1 The calibration corresponding to the currently selected MCACC preset will be used when **EQ ON** is selected. To use another MCACC preset, exit the **HOME MENU** and press **MCACC** to select it before pressing **HOME MENU**.
- 2 After auto calibration with **EQ Type : SYMMETRY (Full Auto MCACC, etc.)**, the graph for the inferred reverb characteristics can be displayed by selecting **Reverb View**. To display the actually measured reverb characteristics after EQ calibration, measure with **EQ ON**.
- 3 The **After** display when measurements have been made using the **Full Auto MCACC** or **Auto MCACC (ALL)** function shows the graph for the inferred reverb characteristics after **EQ Type : SYMMETRY** calibration.
- 4 The reverb characteristics graph is overwritten each time the reverberations are measured. **No Data** is displayed if there is no reverb characteristic data, for example before measurements have been taken.

Checking MCACC Data

At the procedure of *Automatically setting up for surround sound (Auto MCACC & Full Band Phase Control)* on page 42, the procedure of *Automatic MCACC (Expert)* on page 96 or after fine-adjusting at *Manual MCACC setup* on page 98, you can check your calibrated settings using the GUI screen or, if a computer is connected, on the computer's screen.

1 Set the remote control to the receiver operation mode, then press HOME MENU.

A Graphical User Interface (GUI) screen appears on your TV. Use **↑/↓/←/→** and **ENTER** to navigate through the screens and select menu items. Press **RETURN** to confirm and exit the current menu.

2 Select 'MCACC Data Check' from the HOME MENU.

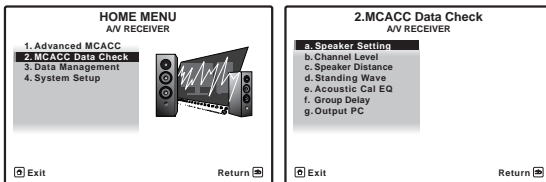

3 Select the setting you want to check.

- **Speaker Setting** – Used to check the settings of the speaker systems. See *Speaker Setting* below for more on this.
- **Channel Level** – Used to check the output level of the different speakers. See *Channel Level* below for more on this.
- **Speaker Distance** – Used to check the distance to the different speakers. See *Speaker Distance* on page 105 for more on this.
- **Standing Wave** – Used to check the standing wave control filter settings. See *Standing Wave* on page 105 for more on this.
- **Acoustic Cal EQ** – Used to check the calibration values of the listening environment's frequency response. See *Acoustic Cal EQ* on page 105 for more on this.
- **Group Delay** – Used to check the speakers' group delay (both before and after calibration). See *Group Delay* on page 105 for more on this.
- **Output PC** – See *Output PC* on page 106 for more on this.

4 Press RETURN to go back to MCACC Data Check menu, repeating steps 2 and 3 to check other settings.

5 When you're finished, press RETURN.

You will return to the **HOME MENU**.

Speaker Setting

Use this to display the speaker size and number of speakers. See *Speaker Setting* on page 109 for more on this.

1 Select 'Speaker Setting' from the MCACC Data Check menu.

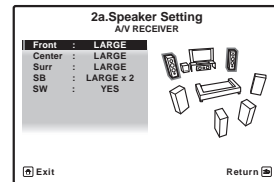

2 Select the channel you want to check.

Use **↑/↓** to select the channel. The corresponding channel on the layout diagram is highlighted.

Channel Level

Use this to display the level of the various channels. See *Channel Level* on page 110 for more on this.

1 Select 'Channel Level' from the MCACC Data Check menu.

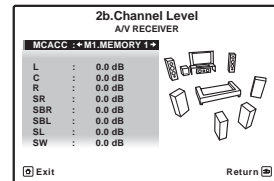

2 When 'MCACC' is highlighted, use ←/→ to select the MCACC preset you want to check.

The level of the various channels set at the selected MCACC preset is displayed. '---' is displayed for channels that are not connected.

Speaker Distance

Use this to display the distance from the different channels to the listening position. See *Speaker Distance* on page 111 for more on this.

- 1 Select 'Speaker Distance' from the MCACC Data Check menu.

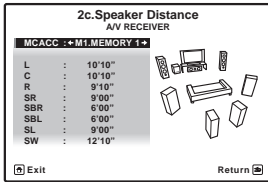

- 2 When 'MCACC' is highlighted, use ←/→ to select the MCACC preset you want to check. The distance from the various channels set at the selected MCACC preset is displayed. '---' is displayed for channels that are not connected.

Standing Wave

Use this to display the standing wave related adjustment values for the various MCACC memories. See *Standing Wave* on page 100 for more on this.

- 1 Select 'Standing Wave' from the MCACC Data Check menu.

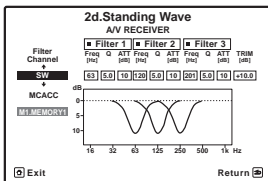

- 2 When 'Filter Channel' is highlighted, use ↑/↓ to select the channel for which you want to check standing wave control. The standing wave related calibration value for the selected channel stored at the selected MCACC preset and its graph are displayed.
- 3 Press ← to highlight 'MCACC', then use ↑/↓ to select the MCACC preset you want to check.

Acoustic Cal EQ

Use this to display the calibration values for the frequency response of the various channels set in the different MCACC presets. See *Acoustic Calibration EQ Adjust* on page 101 for more on this.

- 1 Select 'Acoustic Cal EQ' from the MCACC Data Check menu.

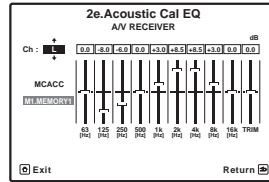

- 2 When 'Ch' is highlighted, use ↑/↓ to select the channel. The calibration value for the frequency response of the selected channel stored at the selected MCACC preset and its graph are displayed.

- 3 Press ← to highlight 'MCACC', then use ↑/↓ to select the MCACC preset you want to check.

Group Delay

Use this to display the calibrated speaker group delay results. See *Using Full Band Phase Control* on page 64 for more on this.

- 1 Select 'Group Delay' from the MCACC Data Check menu.

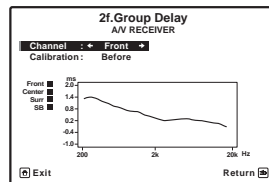

- 2 When 'Channel' is highlighted, use ←/→ to select the channel you want to check. The result of group delay calibration for the selected channel is displayed.

When measurements have been performed with **Full Auto MCACC** selected at **Advanced MCACC** or with **ALL** or **Full Band Phase Ctrl** selected when **Auto MCACC** is selected, the graph before group delay calibration is also displayed.

When **After** is selected at **Calibration**, the group delay after calibration is displayed. Compared to when **Before** is selected, with **After** there is less difference in the delay between frequency bands and the group delay between the different channels is uniform, allowing you to check the full band phase control effect.

No Data is displayed if the selected group delay has not been measured.

Output PC

Before continuing, make sure you have completed step 2 in *Checking MCACC Data* on page 104. The data measured with the Advanced MCACC function is transmitted to the connected computer.¹ The 3D graphs of the reverb characteristics and group delay characteristics before and after calibration and the MCACC results (parameters) can be checked.

1 Select 'Output PC' from MCACC Data Check menu and press ENTER.

When the receiver is ready for transmission, **Start the MCACC application on your PC** shows on the GUI screen.

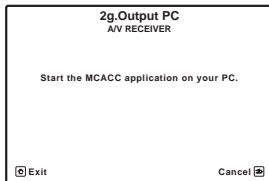

2 Start the MCACC application on your computer.

Follow the instructions provided with the application. It will take about ten seconds for the transmission to complete, then you will be able to analyze the output on your computer. The various parameters, the reverb characteristics and group delay characteristics data used for display on the computer are not cleared when the power is turned off. If the reverb characteristics are re-measured, however, the data is overwritten.²

3 When you're finished, press RETURN.

You will return to the **MCACC Data Check** menu. Continue with other operations in the **MCACC Data Check** menu if necessary. Press **RETURN** again to exit the **MCACC Data Check** menu.

Data Management

This system allows you to store up to six MCACC presets, allowing you to calibrate your system for different listening positions (or frequency adjustments for the same listening position).³ This is useful for alternate settings to match the kind of source you're listening to and where you're sitting (for example, watching movies from a sofa, or playing a video game close to the TV).

From this menu you can copy from one preset to another, name presets for easier identification and clear any ones you don't need.

1 Set the remote control to the receiver operation mode, then press HOME MENU.

A Graphical User Interface (GUI) screen appears on your TV. Use **↑/↓/←/→** and **ENTER** to navigate through the screens and select menu items. Press **RETURN** to confirm and exit the current menu.

2 Select 'Data Management' from the HOME MENU.

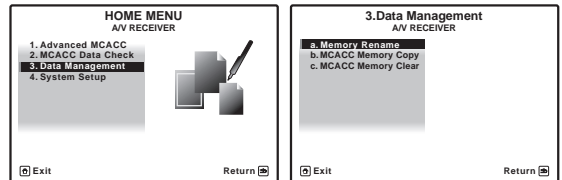

3 Select the setting you want to adjust.

- **Memory Rename** – Name your MCACC presets for easy identification (see *Renaming MCACC presets* below).
- **MCACC Memory Copy** – Copy settings from one MCACC preset to another (see *Copying MCACC preset data* below).
- **MCACC Memory Clear** – Clear any MCACC presets that you don't want (see *Clearing MCACC presets* on page 107).

Note

- ¹ To transmit data, the receiver and computer must be connected using an RS-232C cable and a special application must be installed on the computer. See *Connecting a PC for Advanced MCACC output* on page 38 for more on this.
- ² Only one set of reverb characteristics is stored on the receiver. If you wish to compare several different measurement results, transmit the data to the computer each time reverb measurements are taken.
- ³ This can be done in *Automatically setting up for surround sound (Auto MCACC & Full Band Phase Control)* on page 42 or *Automatic MCACC (Expert)* on page 96, either of which you should have already completed.

Renaming MCACC presets

If you have several different MCACC presets that you're using, you may want to rename them for easier identification.

1 Select 'Memory Rename' from the Data Management setup menu.

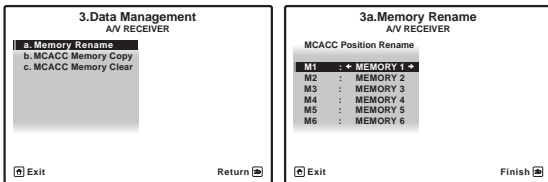

2 Select the MCACC preset you want to rename, then select an appropriate preset name.

Use \uparrow/\downarrow to select the preset, then \leftarrow/\rightarrow to select a preset name.

3 Repeat for as many MCACC presets as necessary, then press RETURN when you're finished.

You will return to the **Data Management** setup menu.

Copying MCACC preset data

If you want to manually adjust the Acoustic Calibration EQ (see *Manual MCACC setup* on page 98), we recommend copying your current settings¹ to an unused MCACC preset. Instead of just a flat EQ curve, this will give you a reference point from which to start.

1 Select 'MCACC Memory Copy' from the Data Management setup menu.

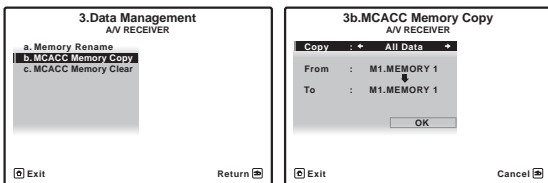

2 Select the setting you want to copy.

- **All Data** – Copies all the settings of the selected MCACC preset memory.
- **Level & Distance** – Copies only the channel level and speaker distance settings of the selected MCACC preset memory.

3 Select the MCACC preset you'll be copying the settings 'From', then specify where you want to copy them ('To').

Make sure you don't overwrite an MCACC preset you're currently using (this can't be undone).

4 Select 'OK' to confirm and copy the settings.

When **MCACC Memory Copy?** is displayed, select **YES**. If **NO** is selected, the memory is not copied.

Completed! shows in the GUI screen to confirm the MCACC preset has been copied, then you automatically return to the **Data Management** setup menu.

Clearing MCACC presets

If you are no longer using one of the MCACC presets stored in memory, you can choose to clear the calibration settings of that preset.

1 Select 'MCACC Memory Clear' from the Data Management setup menu.

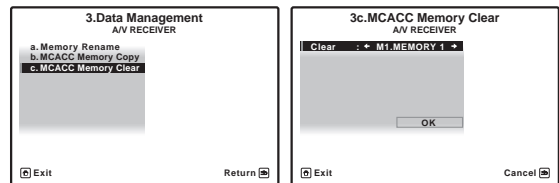

2 Select the MCACC preset you want to clear.

Make sure you don't clear an MCACC preset you're currently using (this can't be undone).

3 Select 'OK' to confirm and clear the preset.

When **MCACC Memory Clear?** is displayed, select **YES**. If **NO** is selected, the memory is not cleared.

Completed! shows in the GUI screen to confirm the MCACC preset has been cleared, then you automatically return to the **Data Management** setup menu.

Note

¹ The settings made in *Automatically setting up for surround sound (Auto MCACC & Full Band Phase Control)* on page 42 or *Automatic MCACC (Expert)* on page 96.

Chapter 12:

The system and the other setup

Making receiver settings from the System Setup menu

The following section describes how to change the speaker-related settings manually and make various other settings (input selection, OSD language selection, etc.).

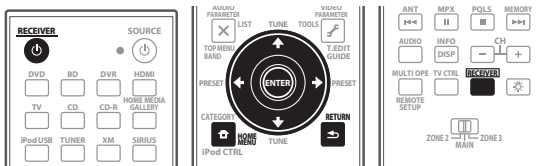

- 1 **Switch on the receiver and your TV.** Use the **RECEIVER** button to switch on.¹

- If headphones are connected to the receiver, disconnect them.

- 2 Press **RECEIVER**, then press **HOME MENU**.²

A Graphical User Interface (GUI) screen appears on your TV. Use **↑/↓/←/→** and **ENTER** to navigate through the screens and select menu items. Press **RETURN** to confirm and exit the current menu.

- Press **HOME MENU** at any time to exit the **HOME MENU**.

- 3 Select 'System Setup' from the **HOME MENU**, then press **ENTER**.

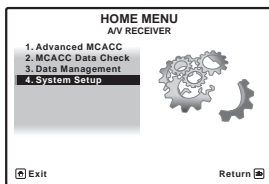

- 4 Select the setting you want to adjust.

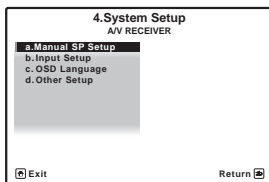

- **Manual SP Setup** – Sets the type of connection used for surround back terminals and the size, number distance and overall balance of the connected speakers (see *Manual speaker setup* below).
- **Input Setup** – Specifies what you've connected to the digital, HDMI and component video inputs (see *The Input Setup menu* on page 44).
- **OSD Language** – The GUI screen's display language can be changed (see *Changing the OSD display language (OSD Language)* on page 42).
- **Other Setup** – Changes customized settings to reflect how you are using the receiver (see *The Other Setup menu* on page 112).

Manual speaker setup

This receiver allows you to make detailed settings to optimize the surround sound performance. You only need to make these settings once (unless you change the placement of your current speaker system or add new speakers).

These settings are designed to customize your system, but if you're satisfied with the settings made in *Automatically setting up for surround sound (Auto MCACC & Full Band Phase Control)* on page 42, it isn't necessary to make all of these settings.

CAUTION

- The test tones used in the **Manual SP Setup** are output at high volume.

- 1 Select 'Manual SP Setup', then press **ENTER**.

See *Making receiver settings from the System Setup menu* above if you're not already at this screen.

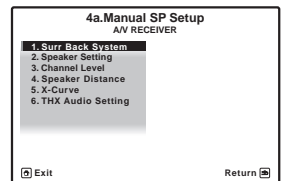
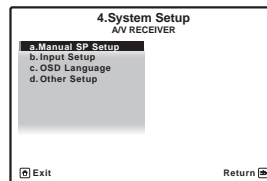

- 2 Select the setting you want to adjust.

If you are doing this for the first time, you may want to adjust these settings in order:

Note

¹ Make sure not to switch off the power when using the System Setup menu.

² You can't use the **HOME MENU** when either the HOME MEDIA GALLERY, XM, SIRIUS or iPod/USB input function is selected or the headphones are connected. When you set **ZONE 2**, **ZONE 3** or **ZONE 2&3** to **ON** (page 85), you can't use the **HOME MENU**.

- **Surr Back System** – Specifies how you are using your surround back speakers (see below).
- **Speaker Setting** – Specifies the size and number of speakers you've connected (see below).
- **Channel Level** – Adjusts the overall balance of your speaker system (page 110).
- **Speaker Distance** – Specifies the distance of your speakers from the listening position (page 111).
- **X-Curve** – Adjusts the tonal balance of your speaker system for movie soundtracks (page 111).
- **THX Audio Setting** – Specifies whether you are using a THX speaker setup (page 111).

3 Make the adjustments necessary for each setting, pressing RETURN to confirm after each screen.

Surround back speaker setting

- Default setting: **Normal**

There are several ways you can use the surround back speaker channels with this system. In addition to a normal home theater setup where they are used for the surround back speakers, they can be used for bi-amping the front speakers or as an independent speaker system in another room.

1 Select 'Surr Back System' from the Manual SP Setup menu.

See *Making receiver settings from the System Setup menu* on page 108 if you're not already at this screen.

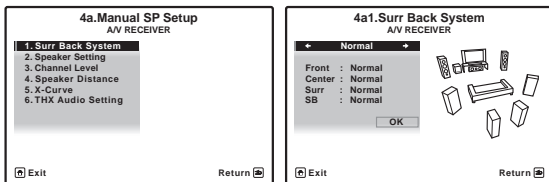

2 Select the surround back speaker setting.

- **Normal** – Select for normal home theater use with surround back speakers in your main (speaker system A) setup.
- **Speaker B** – Select to use the (surround back) B speaker terminals to listen to stereo playback in another room (see *Switching the speaker system* on page 84).
- **Front Bi-Amp** – Select this setting if you're bi-amping your front speakers (see *Bi-amping your speakers* on page 23).
- **ZONE 2** – Select to use the (surround back) B speaker terminals for an independent system in another zone (see *Using the MULTI-ZONE controls* on page 85).

3 When 'Setting Change?' is displayed, select Yes. If No is selected, the setting is not changed.

You will return to the **Manual SP Setup** menu.

Speaker Setting

Use this setting to specify your speaker configuration (size, number of speakers and crossover frequency)¹. It is a good idea to make sure that the settings made in *Automatically setting up for surround sound (Auto MCACC & Full Band Phase Control)* on page 42 are correct. Note that this setting applies to all MCACC presets, and cannot be set independently.

1 Select 'Speaker Setting' from the Manual SP Setup menu.

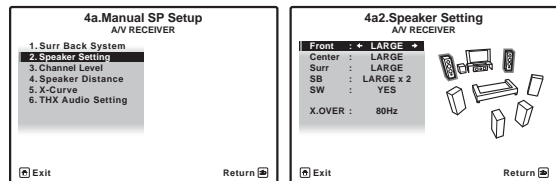

2 Choose the set of speakers that you want to set, then select a speaker size.

Use **←/→** to select the size (and number) of each of the following speakers:²

- **Front** – Select **LARGE** if your front speakers reproduce bass frequencies effectively, or if you didn't connect a subwoofer. Select **SMALL** to send the bass frequencies to the subwoofer.
- **Center** – Select **LARGE** if your center speaker reproduces bass frequencies effectively, or select **SMALL** to send bass frequencies to the other speakers or subwoofer. If you didn't connect a center speaker, choose **NO** (the center channel is sent to the front speakers).
- **Surr** – Select **LARGE** if your surround speakers reproduce bass frequencies effectively. Select **SMALL** to send bass frequencies to the other speakers or subwoofer. If you didn't connect surround speakers choose **NO** (the sound of the surround channels is sent to the front speakers or a subwoofer).

Note

¹ If you're using a THX speaker setup, set all speakers to **SMALL**.

² If you select **SMALL** for the front speakers the subwoofer will automatically be fixed to **YES**. Also, the center, surround and surround back speakers can't be set to **LARGE** if the front speakers are set to **SMALL**. In this case, all bass frequencies are sent to the subwoofer.

- **SB** – Select the number of surround back speakers you have (one, two or none).¹ Select **LARGE_{x2}** or **LARGE_{x1}** if your surround back speakers reproduce bass frequencies effectively. Select **SMALL_{x2}** or **SMALL_{x1}** to send bass frequencies to the other speakers or subwoofer. If you didn't connect surround back speakers choose **NO**.
- **SW** – LFE signals and bass frequencies of channels set to **SMALL** are output from the subwoofer when **YES** is selected. Choose the **PLUS** setting if you want the subwoofer to output bass sound continuously or you want deeper bass (the bass frequencies that would normally come out the front and center speakers are also routed to the subwoofer).² If you did not connect a subwoofer choose **NO** (the bass frequencies are output from other speakers).

3 Select 'X.OVER' and set the crossover frequency.³

Frequencies below this point will be sent to the subwoofer (or **LARGE** speakers).

4 When you're finished, press RETURN.

You will return to the **Manual SP Setup** menu.

Channel Level

Using the channel level settings, you can adjust the overall balance of your speaker system, an important factor when setting up a home theater system.

1 Select 'Channel Level' from the Manual SP Setup menu.

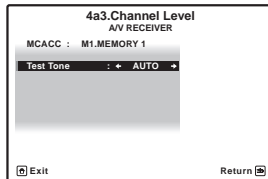
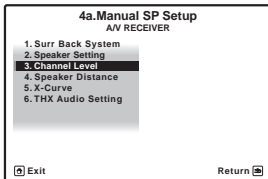

2 Select a setup option.

- **MANUAL** – Move the test tone manually from speaker to speaker and adjust individual channel levels.

Note

- If you selected **Speaker B, ZONE 2** or **Front Bi-Amp** (in *Surround back speaker setting* on page 109) you can't adjust the surround back settings.
 - If the surround speakers are set to **NO**, the surround back speakers will automatically be set to **NO**.
 - If you select one surround back speaker only, make sure that speaker is hooked up to the left surround back terminal.
 - If you have a subwoofer and like lots of bass, it may seem logical to select **LARGE** for your front speakers and **PLUS** for the subwoofer. This may not, however, yield the best bass results. Depending on the speaker placement of your room you may actually experience a decrease in the amount of bass due to low frequency cancellations. In this case, try changing the position or direction of speakers. If you can't get good results, listen to the bass response with it set to **PLUS** and **YES** or the front speakers set to **LARGE** and **SMALL** alternatively and let your ears judge which sounds best. If you're having problems, the easiest option is to route all the bass sounds to the subwoofer by selecting **SMALL** for the front speakers.
 - This setting decides the cutoff between bass sounds playing back from the speakers selected as **LARGE**, or the subwoofer, and bass sounds playing back from those selected as **SMALL**. It also decides where the cutoff will be for bass sounds in the LFE channel.
 - If you're using a THX speaker setup, confirm that the crossover frequency is set to **80Hz**.
 - If you are using a Sound Pressure Level (SPL) meter, take the readings from your main listening position and adjust the level of each speaker to 75 dB SPL (C-weighting/slow reading).
 - The subwoofer test tone is output at low volumes. You may need to adjust the level after testing with an actual soundtrack.
- 5 The channel level cannot be adjusted using this procedure while making settings on **HOME MENU**.

- **AUTO** – Adjust channel levels as the test tone moves from speaker to speaker automatically.

3 Confirm your selected setup option.

The test tones will start after you press **ENTER**.

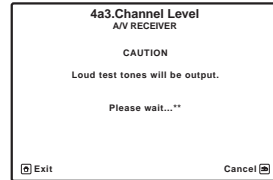

4 Adjust the level of each channel using ←/→.

If you selected **MANUAL**, use **↑/↓** to switch speakers. The **AUTO** setup will output test tones in the order shown on-screen:

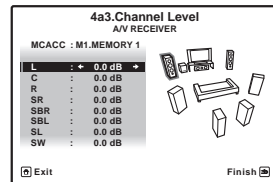

Adjust the level of each speaker as the test tone is emitted.⁴

5 When you're finished, press RETURN.

You will return to the **Manual SP Setup** menu.

Tip

- You can change the channel levels by set the remote control to the receiver operation mode, then press **CH LEVEL**, and then using **←/→** on the remote control.⁵

Speaker Distance

For good sound depth and separation from your system, you need to specify the distance of your speakers from the listening position. The receiver can then add the proper delay needed for effective surround sound.

1 Select 'Speaker Distance' from the Manual SP Setup menu.

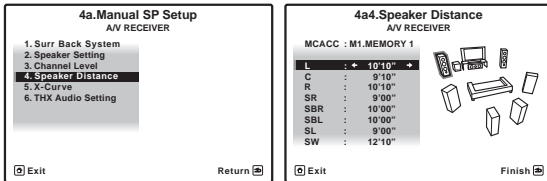

2 Adjust the distance of each speaker using ←/→.

You can adjust the distance of each speaker in 1/2 inch increments.

3 When you're finished, press RETURN.

You will return to the **Manual SP Setup** menu.

Tip

- For best surround sound, make sure the surround back speakers are the same distance from the listening position.

X-Curve

Most soundtracks mixed for cinema sound too bright when played back in large rooms. The X-Curve setting acts as a kind of re-equalization for home theater listening, and restores proper tonal balance of movie soundtracks.¹

1 Select 'X-Curve' from the Manual SP Setup menu.

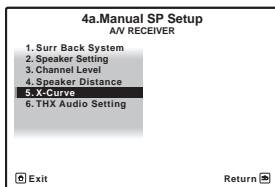

2 Choose the X-Curve setting you want.

Use ←/→ to adjust the setting. The X-Curve is expressed as a downwards slope in decibels per octave, starting at 2 kHz. The sound becomes less bright as the slope increases (to a maximum of **-3.0dB/oct**). Use the following guidelines to set the X-Curve according to your room size:

Room size (ft ²)	≤400	≤550	≤650	≤800	≤2200	≤12000
X-Curve (dB/oct)	-0.5	-1.0	-1.5	-2.0	-2.5	-3.0

- If you select **OFF**, the frequency curve will be flat and the X-Curve has no effect.

3 When you're finished, press RETURN.

THX Audio Setting

This menu allows the user to adjust various THX features including Loudness Plus, SB Speaker Position, THX Select2 Subwoofer (on/off), and Boundary Gain Control. Please see page 129 for a details regarding these THX features.

1 Select 'THX Audio Setting' from the Manual SP Setup menu.

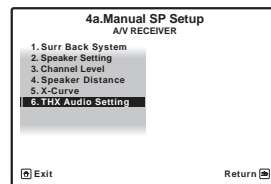

2 Select either ON or OFF for THX Loudness Plus setting.

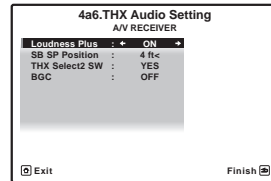

3 Specify the distance of your surround back speakers from each other.

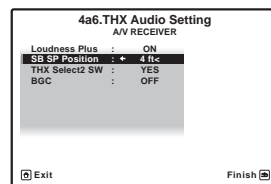

- 0-1 ft** – Surround back speakers within 1 foot apart.
- >1-4 ft** – Surround back speakers between 1 and 4 feet apart.
- 4 ft<** – Surround back speakers more than 4 feet apart (default).

Note

¹ Since the principal is the same, X-Curve isn't applied when you're using any of the Home THX modes (see *Using the Home THX modes* on page 58).

4 Specify whether your subwoofer is THX Select2 certified or not.

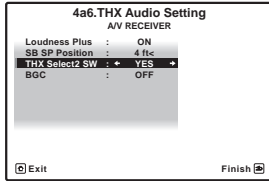

If your subwoofer isn't THX Select2 certified, but you still want to switch boundary gain compensation on, select **YES** here, but the effect might not work properly.

5 Select either ON or OFF for Boundary Gain Compensation (BGC) setting.

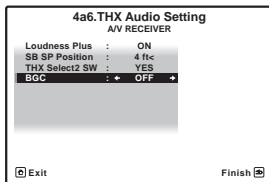

6 When you're finished, press RETURN. You will return to the Manual SP Setup menu.

The Other Setup menu

The **Other Setup** menu is where you can make customized settings to reflect how you are using the receiver.

1 Press **RECEIVER**, then press **HOME MENU**.

A Graphical User Interface (GUI) screen appears on your TV. Use **↑/↓/←/→** and **ENTER** to navigate through the screens and select menu items. Press **RETURN** to confirm and exit the current menu.

2 Select 'System Setup' from the **HOME MENU**.

3 Select 'Other Setup', then press **ENTER**.

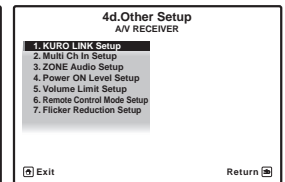
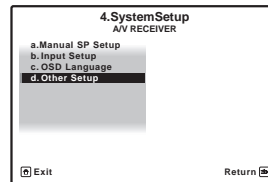

4 Select the setting you want to adjust.

If you are doing this for the first time, you may want to adjust these settings in order:

- **KURO LINK Setup** – Synchronizes this receiver with your Pioneer component supporting KURO LINK (see *KURO LINK Setup* on page 80).
- **Multi Ch In Setup** – Specifies the optional settings for a multi-channel input (see below).
- **ZONE Audio Setup** – Specifies the volume setting for a MULTI-ZONE setup (page 113).
- **Power ON Level Setup** – Specifies the volume level set when the power is turned on (page 113).
- **Volume Limit Setup** – Limits the maximum volume (page 113).
- **Remote Control Mode Setup** – Sets this receiver's remote control mode (page 114).
- **Flicker Reduction** – Adjusts the way the GUI screen looks (page 114).

5 Make the adjustments necessary for each setting, pressing **RETURN** to confirm after each screen.

Multi Channel Input Setup

You can adjust the level of the subwoofer for a multi-channel input. Also, when the multi-channel input is selected as an input function, you can display the video images of other input functions. In the Multi Channel Input Setup, you can assign a video input to the multi-channel input.

1 Select 'Multi Ch In Setup' from the Other Setup menu.

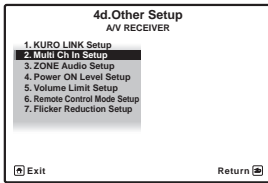

2 Select the 'SW Input Gain' setting you want.

- **0dB** – Outputs sound of the subwoofer at the level originally recorded on the source.
- **+10dB** – Outputs sound of the subwoofer at the level increased by 10 dB.

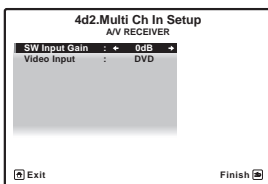

3 Select the 'Video Input' setting you want.

When the multi-channel input is selected as an input function, you can display the video images of other input functions. The video input can be selected from the following: **DVD, TV/SAT, DVR, VIDEO 1, VIDEO 2, OFF.**

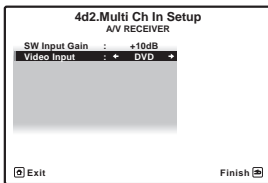

4 When you're finished, press RETURN.

You will return to the **Other Setup** menu.

ZONE Audio Setup

If you've made MULTI-ZONE connections (see *Using the MULTI-ZONE controls* on page 85), you may need to specify your volume setting.

1 Select 'ZONE Audio Setup' from the Other Setup menu.

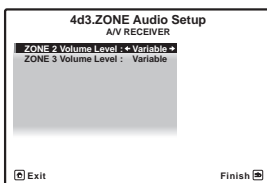
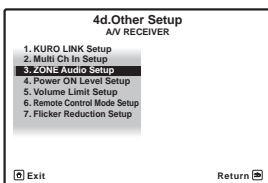

2 Select the volume level setting of ZONE 2¹ and ZONE 3.

- **Variable** – Use this setting if you've connected a power amplifier in the sub room (this receiver is simply being used as a pre-amp) and you will be using this receiver's controls to adjust the volume.
- **Fixed** – Use this setting if you've connected a fully integrated amplifier (such as another Pioneer VSX receiver) in the sub room and want to use that receiver's volume controls.

With the **Fixed** setting, the source is sent from this receiver at maximum volume, so make sure the volume is quite low in the sub zone at first, and then experiment to find the correct level.

3 When you're finished, press RETURN.

You will return to the **Other Setup** menu.

Power ON Level Setup

The volume can be set so that it is always set to the same level when the receiver's power is turned on.

1 Select 'Power ON Level Setup' from the Other Setup menu.

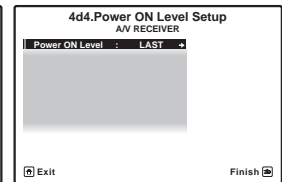
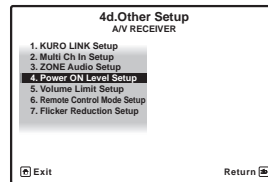

2 Select the Power ON Level setting you want.

- **LAST** – When the power is turned on, the volume is set to the same level as when the power was last turned off.
- **"---** – When the power is turned on, the volume is set to minimum level.
- **-80.0dB to +12.0dB** – Specify the volume to be set when the power is turned, in steps of 0.5 dB.

It is not possible to set a volume level greater than the value specified at Volume Limit Setup.

3 When you're finished, press RETURN.

You will return to the **Other Setup** menu.

Volume Limit Setup

Use this function to limit the maximum volume. The volume cannot be increased above the level set here, even by operating **MASTER VOLUME** button (or the dial on the front panel).

Note

1 If you selected **ZONE 2** in the *Surround back speaker setting* on page 109, you won't be able to change the volume level.

1 Select 'Volume Limit Setup' from the Other Setup menu.

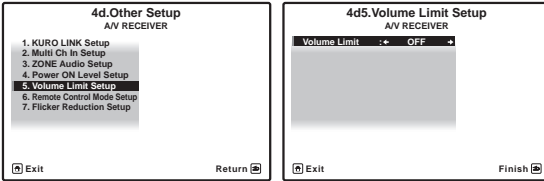

2 Select the Volume Limit setting you want.

- **OFF** – The maximum volume is not limited.
- **-20.0dB/-10.0dB/0.0dB** – The maximum volume is limited to the value set here.

3 When you're finished, press RETURN.

You will return to the **Other Setup** menu.

Remote Control Mode Setup

- Default setting: **1**

This sets this receiver's remote control mode to prevent erroneous operation when multiple units of the receiver are being used.¹

1 Select 'Remote Control Mode Setup' from the Other Setup menu.

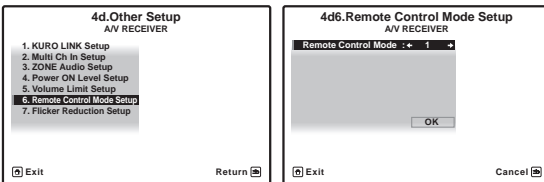

2 Select the Remote Control Mode setting you want.

3 Select "OK" to change the remote control mode.

4 Follow the instructions on the screen to change the remote control's setting.

See *Operating multiple receivers* (page 89).

5 When you're finished, press RETURN.

You will return to the **Other Setup** menu.

Flicker Reduction Setup

- Default setting: **4**

The GUI screen's resolution can be increased. If you feel the GUI screen is hard to see, try changing this setting. Note that the resolution in this setting only affects the GUI screen; it has no influence on the video output.

1 Select 'Flicker Reduction Setup' from the Other Setup menu.

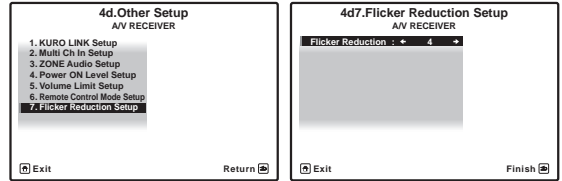

2 Select the Flicker Reduction setting you want.

3 When you're finished, press RETURN.

You will return to the **Other Setup** menu.

Note

¹ If you change this receiver's setting, also change the setting on the remote control.

Chapter 13: Additional information

Speaker Setting Guide

In order to achieve an even better surround effect, it is important to accurately position the speakers and make their volume and tone characteristics uniform so as to finely focus the multi-channel sound.

The three major elements in positioning the speakers are **distance**, **angle** and **orientation** (the direction in which the speakers are pointing).

Distance: The distance of all the speakers should be equal.

Angle: The speakers should be horizontally symmetrical.

Orientation: The orientation should be horizontally symmetrical.

In most homes, however, it is not possible to achieve this environment. For the distance, on this receiver it is possible to automatically correct the speaker distance electrically to a precision of $\frac{1}{2}$ inch using the Auto MCACC Setup function (page 42). For the volume and sound quality as well, accurate sound field correction using the equalizer and speaker phase characteristic correction using the Full Band Phase Control function (page 63) together make it possible to achieve the ideal listening environment.

Step 1: Speaker layout and distance adjustment

Use speaker stands or the like to make sure the speakers are steady, and leave at least 10 cm (4 inches) from the surrounding walls. Position the speakers attentively so that the speakers on the left and right are at equal angles from the listening position (center of the adjustments). (We recommend using cords, etc., when adjusting the layout.) Ideally all the speakers should be equidistant from the listening position.



Tip

- If the speakers cannot be set at equal distances (on a circle), use the Auto MCACC Setup speaker distance correction and Fine Speaker Distance functions to make them equalize the distance artificially.

Step 2: Adjusting the speaker height

Adjust the heights (angles) of the different speakers.

Adjust so that the front speaker units reproducing mid and high frequencies is roughly at the height of the ears.

If the center speaker cannot be set at the same height as the front speakers, adjust its angle of elevation to point it to the listening position.

Set surround speaker 1 so that it is not under the height of the ears.

Step 3: Adjusting the speaker orientation

If the left and right speakers are not pointing in the same direction, the tone will not be the same on the right and left, and as a result the sound field will not be reproduced properly. However, if all the speakers are pointed towards the listening position, the sound field will seem cramped. Testing by the Pioneer Multi-channel Research Group has shown that a good sense of sound positioning can be achieved by pointing all the speakers towards an area 30 cm (12 inches) to 80 cm (31 inches) behind the listening position (between the surround speakers and the listening position).

However, the sense of sound positioning can differ according to the conditions in the room and the speakers being used. In smaller environments in particular (when the front speakers are close to the listening position), with this method the speakers will be pointed too inward. We suggest you use this example of installation as reference when trying out different installation methods.

Step 4: Positioning and adjusting the subwoofer

Placing the subwoofer between the center and front speakers makes even music sources sound more natural (If there is only one subwoofer, it doesn't matter if it is placed on the left or right side). The low bass sound output from the subwoofer is not directional and there is no need to adjust the height. Normally the subwoofer is placed on the floor. Put it in a position at which it will not cancel out the bass sound output from the other speakers. Also note that placing it near a wall may result in sympathetic vibrations with the building that could excessively amplify the bass sound.

If the subwoofer must be installed near a wall, place it at an angle so that it is not parallel to the wall surface. This can help reduce any sympathetic vibrations, but depending on the shape of the room this could result in standing waves. However, even if standing waves are generated, their influence on the sound quality can be prevented using the Auto MCACC's standing wave control function (page 105).

Step 5: Default settings with the Auto MCACC Setup (auto sound field correction) function

It is more effective to perform the Auto MCACC Setup (page 42) procedure once the adjustments described above have been completed.

Tip

- The distance to the subwoofer may be slightly larger than the distance actually measured with a tape measure, etc. This is because this distance is corrected for electric delay, and is not a problem.

Positional relationship between speakers and monitor

Position of front speakers and monitor

The front speakers should be as equidistant as possible to the monitor.

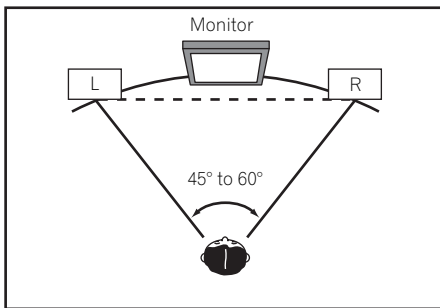

Position of center speaker and monitor

Since mostly dialogs are output from the center speaker, keeping the center speaker as close as possible to the screen makes the overall sound more natural. For TVs using Braun tubes, however, when installing the center speaker on the floor, adjust its angle of elevation to point it towards the listening position.

Installation on floor

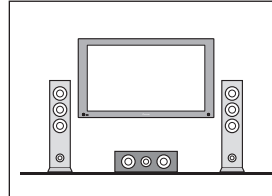

(Diagram as seen from the side)

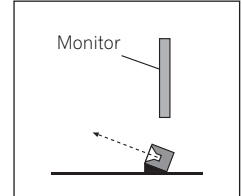

- If the center speaker is not of the shielded type, install it away from the TV.
- When installing the center speaker on top of the monitor, place it facing slightly downwards towards the listening position.

Troubleshooting

Incorrect operations are often mistaken for trouble and malfunctions. If you think that there is something wrong with this component, check the points below. Sometimes the trouble may lie in another component. Investigate the other components and electrical appliances being used. If the trouble cannot be rectified even after exercising the checks listed below, ask your nearest Pioneer authorized independent service company to carry out repair work.

Note

- If the unit does not operate normally due to external effects such as static electricity disconnect the power plug from the outlet and insert again to return to normal operating conditions.

Power

Symptom	Remedy
The power does not turn on.	<ul style="list-style-type: none"> Make sure that the power cord is plugged in to an active power outlet. Try disconnecting from the power outlet, then plugging back in.
Power cannot be turned off. (ZONE 2 ON or ZONE 3 ON is displayed.)	<ul style="list-style-type: none"> Set the remote control's MULTI-ZONE operation selector switch to ZONE 2 or ZONE 3, then press RECEIVER to switch the sub zone off.
The receiver suddenly switches off or the PHASE CONTROL indicator blinks.	<ul style="list-style-type: none"> Check that there are no loose strands of speaker wire touching the rear panel or another set of wires. If so, re-attach the speaker wires, making sure there are no stray strands. The receiver may have a serious problem. Disconnect from the power and call a Pioneer authorized independent service company.
During loud playback the power suddenly switches off.	<ul style="list-style-type: none"> Turn down the volume. Lower the 63 Hz and 125 Hz equalizer levels in the <i>Manual MCACC setup</i> on page 98. Switch on the digital safety feature. While holding down ENTER on the front panel, press STANDBY/ON to set this receiver to the standby mode. Use ↑/↓ to select D.SAFETY <OFF>, and then use ←/→ to select 1 or 2 (select D.SAFETY <OFF> to deactivate this feature). If the power switches off even with 2 switched on, turn down the volume. With 1 or 2 on, some features may be unavailable.

Symptom	Remedy
The unit does not respond when the buttons are pressed.	<ul style="list-style-type: none"> • Try switching the receiver off, then back on again. • Try disconnecting the power cord, then connect again.
AMP ERR blinks in the display, then the power automatically switches off. The power indicator blinks and the power does not turn on.	<ul style="list-style-type: none"> • Try tuning on the power after 1 minute.
AMP ERR blinks in the display, then the power automatically switches off. The ADVANCED MCACC blinks and the power does not turn on.	<ul style="list-style-type: none"> • The receiver may have a serious problem. Do not try switching the receiver on. Unplug the receiver from the wall and call a Pioneer authorized independent service company.
The PQLS indicator flashes and power turns off. FAN STOP is displayed.	<ul style="list-style-type: none"> • There is a problem with the receiver's fan. Try turning on the power. If the same thing happens, the receiver is damaged. Unplug the receiver from the wall and call a Pioneer authorized independent service company.
The ADVANCED MCACC indicator flashes and power turns off.	<ul style="list-style-type: none"> • There is a problem with the receiver's power unit. The receiver may have a serious problem. Unplug the receiver from the wall and call a Pioneer authorized independent service company.
AMP OVERHEAT (or OVERHEAT) and the power indicator flash and the power turns off.	<ul style="list-style-type: none"> • Allow the unit to cool down in a well-ventilated place before switching back on. • Wait at least 1 minute, then try turning the power on again.
The Receiver suddenly power off or the blue indicator at the center of the receiver flashes.	<ul style="list-style-type: none"> • The power unit is damaged. Unplug the receiver from the wall and call a Pioneer authorized independent service company.
Display blinks 12V TRG ERR .	<ul style="list-style-type: none"> • An error has arisen in the 12 V trigger jacks. Reconnect accurately then turn the power back on.

No sound

Symptom	Remedy
No sound is output when an input function is selected.	<ul style="list-style-type: none"> • Check the volume, mute setting (press MUTE) and speaker setting (press SPEAKERS). • Make sure the correct input function is selected.
No sound output from the front speakers.	<ul style="list-style-type: none"> • Check that the MCACC setup microphone is disconnected. • Make sure the correct input signal is selected (press SIGNAL SEL). Note that when PCM is selected, you won't be able to hear any other signal format. • Check that the source component is connected properly (see <i>Connecting your equipment</i> on page 17). • Check that the speakers are connected properly (see <i>Connecting the speakers</i> on page 21).
No sound from the surround or center speakers.	<ul style="list-style-type: none"> • Check that the Stereo listening mode or the Front Stage Surround Advance mode isn't selected; select one of the surround listening modes (see <i>Listening in surround sound</i> on page 57). • Check that the surround/center speakers are not set to NO (see <i>Speaker Setting</i> on page 109). • Check the channel level settings (see <i>Channel Level</i> on page 110). • Check the speaker connections (see <i>Connecting the speakers</i> on page 21).
No sound from surround back speakers.	<ul style="list-style-type: none"> • Check that the surround back speakers are set to LARGE or SMALL (see <i>Speaker Setting</i> on page 109). • Make sure surround back channel processing is set to SBch ON (see <i>Using surround back channel processing</i> on page 61). • If the source is Dolby Surround EX or DTS-ES with no flag to indicate 6.1 compatibility, then with surround back channel processing set to SBch Auto, there will be no sound from the surround back speakers. In this case, set to SBch ON (see <i>Using surround back channel processing</i> on page 61). • If the source does not have 6.1 playback channels, make sure that surround back channel processing is set to SBch ON and a surround mode is selected (see <i>Listening in surround sound</i> on page 57). • Check the speaker connections (see <i>Connecting the speakers</i> on page 21). <p>If only one surround back speaker is connected, make sure it's connected to the left channel speaker terminal.</p>

Symptom	Remedy
No sound from subwoofer.	<ul style="list-style-type: none"> • Check that the subwoofer is connected properly, switched on and the volume turned up. • If your subwoofer has a sleep function, make sure it is switched off. • Make sure that the Subwoofer setting is YES or PLUS (see <i>Speaker Setting</i> on page 109). • The crossover frequency may be set too low; try setting it higher to match the characteristics of your other speakers (see <i>Speaker Setting</i> on page 109). • If there is very little low frequency information in the source material, change your speaker settings to Front: SMALL / Subwoofer: YES, or Front: LARGE / Subwoofer: PLUS (see <i>Speaker Setting</i> on page 109). • Check that the LFE channel is not set to OFF, or a very quiet setting (see <i>Setting the Audio options</i> on page 82). • Check the speaker level settings (see <i>Channel Level</i> on page 110).
No sound from one speaker.	<ul style="list-style-type: none"> • Check the speaker connection (see <i>Connecting the speakers</i> on page 21). • Check the speaker level settings (see <i>Channel Level</i> on page 110). • Check that the speaker hasn't been set to NO (see <i>Speaker Setting</i> on page 109). • The channel may not be recorded in the source. By using one of the advanced effect listening mode, you may be able to create the missing channel (see <i>Listening in surround sound</i> on page 57).
Sound is produced from analog components, but not from digital ones (DVD, LD, CD-ROM, etc.).	<ul style="list-style-type: none"> • Check that the input signal type is set to DIGITAL (see <i>Choosing the input signal</i> on page 63). • Make sure that the digital input is assigned correctly for the input jack the component is connected to (see <i>The Input Setup menu</i> on page 44). • Check the digital output settings on the source component. • If the source component has a digital volume control, make sure this is not turned down. • Make sure that the multichannel analog inputs are not selected. Select any other input function.
No sound is output or a noise is output when Dolby Digital/DTS software is played back.	<ul style="list-style-type: none"> • Check that your DVD player is compatible with Dolby Digital/DTS discs. • Check the digital output settings of your DVD player. Make sure that the DTS signal output is set to On. • If the source component has a digital volume control, make sure this is not turned down.
No sound when using the HOME MENU .	<ul style="list-style-type: none"> • If the HDMI input function is selected, sound is muted until exiting the HOME MENU.

Other audio problems

Symptom	Remedy
Broadcast stations cannot be selected automatically, or there is considerable noise in radio broadcasts.	<p><i>For FM broadcasts</i></p> <ul style="list-style-type: none"> • Fully extend the FM wire antenna, adjust the position for best reception and secure to a wall, etc. • Use an outdoor antenna for better reception (see page 34). <p><i>For AM broadcasts</i></p> <ul style="list-style-type: none"> • Adjust the position and direction of the AM antenna. • Use an outdoor antenna for better reception (see page 34). • Noise may be caused by interference from other equipment, such as a fluorescent light, motor, etc. Switch off or move the other equipment, or move the AM antenna.
A multichannel DVD source appears to be downmixed to 2 channels during playback.	<ul style="list-style-type: none"> • Make sure that the multichannel analog inputs are selected (see <i>Selecting the multichannel analog inputs</i> on page 47).
Noise is output when scanning a DTS CD.	<ul style="list-style-type: none"> • This is not a malfunction of the receiver. The scan function of your player alters the digital information, making it unreadable, resulting in noise being output. Lower the volume when scanning.
When playing a DTS format LD there is audible noise on the soundtrack.	<ul style="list-style-type: none"> • Make sure that the input signal type is set to DIGITAL (see <i>Choosing the input signal</i> on page 63).
Can't record audio.	<ul style="list-style-type: none"> • You can only make a digital recording from a digital source, and an analog recording from an analog source. • For digital sources, make sure that what you're recording isn't copy protected. • Check that the OUT jacks are properly connected to the recorder's input jacks (see <i>Connecting other audio components</i> on page 32).
Subwoofer output is very low.	<ul style="list-style-type: none"> • To route more signal to the subwoofer, set it to PLUS or set the front speakers to SMALL (see <i>Speaker Setting</i> on page 109).

Symptom	Remedy
Everything seems to be set up correctly, but the playback sound is odd.	<ul style="list-style-type: none"> The speakers may be out of phase. Check that the positive/negative speaker terminals on the receiver are matched with the corresponding terminals on the speakers (see <i>Connecting the speakers</i> on page 21).
The PHASE CONTROL feature doesn't seem to have an audible effect.	<ul style="list-style-type: none"> If applicable, check that the lowpass filter switch on your subwoofer is off, or the lowpass cutoff is set to the highest frequency setting. If there is a PHASE setting on your subwoofer, set it to 0° (or depending on the subwoofer, the setting where you think it has the best overall effect on the sound). Make sure the speaker distance setting is correct for all speakers (see <i>Speaker Distance</i> on page 111).
Noise or hum can be heard even when there is no sound being input.	<ul style="list-style-type: none"> Check that personal computers or other digital components connected to the same power source are not causing interference.
There seems to be a time lag between the speakers and the output of the subwoofer.	<ul style="list-style-type: none"> See <i>Automatically setting up for surround sound (Auto MCACC & Full Band Phase Control)</i> on page 42 to set up your system again using MCACC (this will automatically compensate for a delay in the subwoofer output).
The maximum volume available (shown in the front panel display) is lower than the +12dB maximum.	<ul style="list-style-type: none"> Check that the Volume Limit is set to OFF (see <i>Volume Limit Setup</i> on page 113).
Some of the input functions cannot be selected using the INPUT SELECTOR on the front dial or INPUT SELECT on remote control.	<ul style="list-style-type: none"> Make sure that the function is set to ON at the Input Skip function on the Input Setup menu (page 44). Make sure that HDMI Input on the Input Setup menu is set to OFF (page 44).

Video

Symptom	Remedy
No image is output when an input is selected.	<ul style="list-style-type: none"> Check the video connections of the source component (see page 30). For HDMI, or when digital video conversion is set to OFF and a TV and another component are connected with different cords (in <i>Setting the Video options</i> on page 83), you must connect your TV to this receiver using the same type of video cable as you used to connect your video component. Make sure the input assignment is correct for components connected using component video, HDMI or S-Video cables (see <i>The Input Setup menu</i> on page 44). Check the video output settings of the source component. Check that the video input you selected on your TV is correct. Some components (such as video game units) have resolutions that may not be converted. If adjusting this receiver's Resolution setting (in <i>Setting the Video options</i> on page 83) and/or the resolution settings on your component or display doesn't work, try switching Digital Video Conversion (in <i>Setting the Video options</i> on page 83) OFF.
Can't record video.	<ul style="list-style-type: none"> Check that the source is not copy-protected. The video converter is not available when making recordings. Check that the same type of video cable is used for connecting both the recorder and the video source (the one you want to record) to this receiver.
Noisy, intermittent, or distorted picture.	<ul style="list-style-type: none"> Sometimes a video deck may output a noisy video signal (during scanning, for example), or the video quality may just be poor (with some video game units, for example). The picture quality may also depend on the settings, etc. of your display device. Switch off the video converter and reconnect the source and display device using the same type of connection (component, S-Video or composite), then start playback again.
Video signals are not output from the component terminal.	<ul style="list-style-type: none"> When a monitor only compatible with resolutions of 480i is connected to the component terminal and another monitor is connected to the HDMI terminal, the video signals may not be output to the monitor connected to the component terminal. If this happens, do the following: <ul style="list-style-type: none"> Turn off the power of the monitor connected to the HDMI terminal. Set RES on the VIDEO PARAMETER menu to PURE (page 83).

Settings

Symptom	Remedy
The Auto MCACC Setup continually shows an error.	<ul style="list-style-type: none"> The ambient noise level may be too high. Keep the noise level in the room as low as possible (see also <i>Problems when using the Auto MCACC Setup</i> on page 44). If the noise level cannot be kept low enough, you will have to set up the surround sound manually (page 108). When using only one surround back speaker, connect it to the SURROUND BACK L (Single) terminals. To use a 5.1-channel speaker set, use the surround speakers for the surround channel, not the surround back channel. Make sure there are no obstacles between the speakers and the microphone. If Reverse Phase is displayed, try the following: <ul style="list-style-type: none"> The speaker's wiring (+ and -) may be inverted. Check the speaker connections. If the speaker is not pointed to the microphone (listening position) or when using speakers that affect the phase (dipole speakers, reflective speakers, etc.), it may not be possible to properly identify the polarity. Depending on the type of speakers and their installation conditions, Reverse Phase may be displayed even if the speakers are properly connected. If this happens, select GO NEXT and continue.
After using the Auto MCACC Setup, the speaker size setting is incorrect.	<ul style="list-style-type: none"> There may have been some low frequency noise in the room from an air-conditioner, motor, etc. Switch off all other appliances in the room and use Auto MCACC Setup again. Depending on a number of factors (room size, speaker placement, etc.) this may occur in some cases. Change the speaker setting manually in <i>Speaker Setting</i> on page 109, and use the ALL (Keep SP System) option for the Auto MCACC menu in <i>Automatic MCACC (Expert)</i> on page 96 if this is a recurring problem.
Can't adjust the Fine Speaker Distance setting (page 100) properly.	<ul style="list-style-type: none"> Check that the speakers are all in phase (make sure the positive (+) and negative (-) terminals are matched up properly).
The display shows KEY LOCK ON when you try to make settings.	<ul style="list-style-type: none"> With the receiver in standby, press STANDBY/ON while holding down SPEAKERS to disable the key lock.
Most recent settings have been erased.	<ul style="list-style-type: none"> The power cord was disconnected from the wall while adjusting this setting. Settings are only stored if all the zones are turned off. Turn off all the zones before unplugging the power cord.
The various system settings are not stored.	<ul style="list-style-type: none"> After all the zones have been turned off, make sure the blue STANDBY/ON light has gone out before unplugging.

Professional Calibration EQ graphical output

Symptom	Remedy
The EQ response displayed in the graphical output following calibration does not appear entirely flat.	<ul style="list-style-type: none"> There are cases where the graph does not appear flat (even when selecting ALL CH ADJ in the Auto MCACC Setup) due to adjustments made to compensate for room characteristics to achieve optimal sound. Areas of the graph may appear identical (before and after) when there is little or no adjustment needed. The graph may appear to have shifted vertically when comparing before and after measurements.
EQ adjustments made using the <i>Manual MCACC setup</i> on page 98 do not appear to change the graphical output.	<ul style="list-style-type: none"> Despite level adjustments being made, the filters used for analysis may not display these adjustments in the graphical output. However, these adjustments are taken into account by the filters dedicated to overall system calibration.
Lower frequency response curves do not seem to have been calibrated for SMALL speakers.	<ul style="list-style-type: none"> Low frequencies used in bass management (the subwoofer channel) will not change for speakers that have been specified as SMALL in the configuration, or do not output these frequencies. Calibration is performed, but due to your speakers' low frequency limitations, no measurable sound is output for display.

Display

Symptom	Remedy
The display is dark or off.	<ul style="list-style-type: none"> Press DIMMER repeatedly to select a different brightness.
After making an adjustment the display goes off.	<ul style="list-style-type: none"> Press DIMMER repeatedly to select a different brightness.
You can't get DIGITAL to display when using SIGNAL SEL .	<ul style="list-style-type: none"> Check the digital connections and make sure that the digital inputs are assigned correctly (see <i>The Input Setup menu</i> on page 44). If the multichannel analog inputs are selected, select a different input function.
DD DIGITAL or DTS does not light when playing Dolby/DTS software.	<ul style="list-style-type: none"> These indicators does not light if playback is paused. Check the playback (especially the digital output) settings of the source component.
When playing Dolby Digital or DTS sources, the receiver's format indicators do not light.	<ul style="list-style-type: none"> Check that the player is connected using a digital connection. Make sure that the receiver is set to AUTO or DIGITAL (see <i>Choosing the input signal</i> on page 63). Check that the player isn't set up so that Dolby Digital and DTS sources are converted to PCM. Ensure that if there are several audio tracks on the disc, the Dolby Digital or DTS is selected.
When playing certain discs, none of the receiver's format indicators light.	<ul style="list-style-type: none"> The disc may not contain 5.1/6.1 channel material. Check the disc packaging for more on what audio tracks are recorded on the disc.
When playing a disc with the listening mode set to Auto Surround or ALC, DD PL II or Neo:6 appear on the receiver.	<ul style="list-style-type: none"> Make sure that the receiver is set to AUTO or DIGITAL (see <i>Choosing the input signal</i> on page 63). If a two channel soundtrack is currently playing (including Dolby Surround encoded), then this is not a malfunction. Check the disc packaging for details about the audio tracks available.
During playback of a Surround EX or DTS-ES source on the SBch AUTO setting, EX or ES does not appear, or the signal is not properly processed.	<ul style="list-style-type: none"> The source may be Dolby Surround EX/DTS-ES software, but it has no flag to indicate it is 6.1 compatible. Set to SBch ON (see <i>Using surround back channel processing</i> on page 61), then switch to the THX Surround EX or Standard EX listening mode (see <i>Listening in surround sound</i> on page 57).
During playback of DVD-Audio, the display shows PCM .	<ul style="list-style-type: none"> This will occur when playing DVD-Audio material over the HDMI connection. This is not a malfunction.
The power turns off automatically and some indicator flashes, or some indicator flashes and the power does not turn on.	<ul style="list-style-type: none"> See the Power section (page 116).

Remote control

Symptom	Remedy
Cannot be remote controlled.	<ul style="list-style-type: none"> Set a 5-digit preset code corresponding to the receiver to be operated in the remote control (see <i>Operating multiple receivers</i> on page 89). Check whether the receiver's remote control mode is properly set (see <i>Remote Control Mode Setup</i> on page 114). Try replacing the batteries in the remote control (see <i>Loading the batteries</i> on page 11). Be sure to operate within 7 m (23 feet) and a 30° angle of the remote sensor on the front panel (see <i>Operating range of remote control unit</i> on page 11). Check that there are no obstacles between the receiver and the remote control. Make sure that there is no fluorescent or other strong light shining on to the remote sensor. Check the connections of the CONTROL IN jack (see <i>Operating other Pioneer components with this unit's sensor</i> on page 37).
Other components can't be operated with the system remote.	<ul style="list-style-type: none"> If the battery ran down, the preset codes may have been cleared. Re-enter the preset codes. The preset code may be incorrect. Redo the procedure for entering preset codes.

HDMI

Symptom	Remedy
The HDMI indicator blinks continuously.	<ul style="list-style-type: none"> • Check all the points below.
No picture or sound.	<ul style="list-style-type: none"> • This receiver is HDCP-compatible. Check that the components you are connecting are also HDCP-compatible. If they are not, please connect them using the component, S-Video or composite video jacks. • Depending on the connected source component, it's possible that it will not work with this receiver (even if it is HDCP-compatible). In this case, connect using the component, S-Video or composite video jacks between source and receiver. • If the problem still persists when connecting your HDMI component directly to your monitor, please consult the component or monitor manual or contact the manufacturer for support. • If video images do not appear on your TV or flat panel TV, try adjusting the resolution, Deep Color or other setting for your component. • While analog video signals are being output over HDMI, use a separate connection for audio output. • When this receiver reproduces MULTI CH IN audio sources with the HDMI setting set to THROUGH, you cannot hear audio output from all channels. In this case, make a digital or analog audio connection. • To output signals in Deep Color, use an HDMI cable (High Speed HDMI™ Cable) to connect this receiver to a component or TV with the Deep Color feature.
No picture.	<ul style="list-style-type: none"> • Try changing the Resolution setting (in <i>Setting the Video options</i> on page 83). • Set the HDMI output setting to the connected HDMI OUT terminal (in <i>Switching the HDMI output</i> on page 87).
No sound, or sound suddenly ceases.	<ul style="list-style-type: none"> • Check that the HDMI AV setting is set to AMP/THROUGH. • If the component is a DVI device, use a separate connection for the audio. • If analog video is being output over HDMI, please use a separate connection for the audio. • Check the audio output settings of the source component.
Noisy or distorted picture.	<ul style="list-style-type: none"> • Sometimes a video deck may output a noisy video signal (during scanning, for example), or the video quality may just be poor (with some video game units, for example). The picture quality may also depend on the settings, etc. of your display device. Switch off the video converter and reconnect the source and display device using the same type of connection (component, S-Video or composite), then start playback again. • If the problem still persists when connecting your HDMI component directly to your monitor, please consult the component or monitor manual or contact the manufacturer for support.
HDCP ERROR shows in the display.	<ul style="list-style-type: none"> • Check whether or not the connected component is compatible with HDCP. If it is not compatible with HDCP, reconnect the source device using a different type of connection (component, S-Video or composite). Some components that are compatible with HDCP still cause this message to be displayed, but so long as there is no problem with displaying video, this is not a malfunction.

Symptom	Remedy
Amp-linked operation not possible using KURO LINK function.	<ul style="list-style-type: none"> • Check the HDMI connections. • The cable may be damaged. • Select ON for the KURO LINK setting (see <i>KURO LINK Setup</i> on page 80). • Turn the TV's power on before turning on this receiver's power. • Set the TV side KURO LINK setting to ON. • Connect the TV to the HDMI OUT 1 terminal and set the HDMI output to HDMI OUT 1. Then turn on first the TV's power, then this receiver's power.

Important information regarding the HDMI connection

There are cases where you may not be able to route HDMI signals through this receiver (this depends on the HDMI-equipped component you are connecting—check with the manufacturer for HDMI compatibility information).

If you aren't receiving HDMI signals properly through this receiver (from your component), please try one of the following configurations when connecting up.

Configuration A

Use component video cables to connect the video output of your HDMI-equipped component to the receiver's component video input. The receiver can then convert the analog component video signal to a digital HDMI signal for transmission to the display. For this configuration, use the most convenient connection (digital is recommended) for sending audio to the receiver. See the operating instructions for more on audio connections.



Note

- The picture quality will change slightly during conversion.

Configuration B

Connect your HDMI-equipped component directly to the display using an HDMI cable. Then use the most convenient connection (digital is recommended) for sending audio to the receiver. See the operating instructions for more on audio connections. Set the display volume to minimum when using this configuration.



Note

- If your display only has one HDMI terminal, you can only receive HDMI video from the connected component.
- Depending on the component, audio output may be limited to the number of channels available from the connected display unit (for example audio output is reduced to 2 channels for a monitor with stereo audio limitations).
- If you want to switch the input function, you'll have to switch functions on both the receiver and your display unit.
- Since the sound is muted on the display when using the HDMI connection, you must adjust the volume on the display every time you switch input functions.

HOME MEDIA GALLERY

Symptoms	Causes	Remedies
Cannot access the network.	The LAN cable is not firmly connected.	Firmly connect the LAN cable (page 67).
	The router is not switched on.	Switch on the router.
	Internet security software is currently installed in the connected component.	There are cases where a component with Internet security software installed cannot be accessed.
	The audio component on the network which has been switched off is switched on.	Switch on the audio component on the network before switching on this receiver.
Playback does not start while 'Connecting...' continues to be displayed.	The component is currently disconnected from this receiver or the power supply.	Check whether the component is properly connected to this receiver or the power supply.

Symptoms	Causes	Remedies
The PC or Internet radio is not properly operated.	The corresponding IP address is not properly set.	Switch on the built-in DHCP server function of your router, or set up the network manually according to your network environment (page 74).
	The IP address is being automatically configured.	The automatic configuration process takes time. Please wait.
The audio files stored on components on the network, such as a PC, cannot be played back.	Windows Media Player 11 is not currently installed on your PC.	Install Windows Media Player 11 on your PC (page 67).
	Audio files were recorded in formats other than MP3, WAV (LPCM only), MPEG-4 AAC, FLAC, and WMA.	Play back audio files recorded in MP3, WAV (LPCM only), MPEG-4 AAC, FLAC, or WMA. Note that some audio files recorded in these formats may not be played back on this receiver.
	Audio files recorded in MPEG-4 AAC or FLAC are being played back on Windows Media Player 11 or Windows Media Connect.	Audio files recorded in MPEG-4 AAC or FLAC cannot be played back on Windows Media Player 11 or Windows Media Connect. Try using another server. Refer to the operation manual supplied with your server.
	The component connected to the network is not properly operated.	Check whether the component is affected by special circumstances or is in the sleep mode. Try rebooting the component if necessary.
	The component connected to the network does not permit file sharing.	Try changing the settings for the component connected to the network.
Cannot access the component connected to the network.	The folder stored on the component connected to the network has been deleted or damaged.	Check the folder stored on the component connected to the network.
	The component connected to the network is not properly set.	If the client is automatically authorized, you need to enter the corresponding information again. Check whether the connection status is set to "Do not authorize".
	There are no playable audio files on the component connected to the network.	Check the audio files stored on the component connected to the network.
Audio playback is undesirably stopped or disturbed.	The audio file currently being played back was not recorded in a format playable on this receiver.	Check whether the audio file was recorded in a format supported by this receiver. Check whether the folder has been damaged or corrupted. Note that there are cases where even the audio files listed as playable on this receiver cannot be played back or displayed (page 73).
	The LAN cable is currently disconnected.	Connect the LAN cable properly (page 67).
	There is heavy traffic on the network with the Internet being accessed on the same network.	Use 100BASE-TX to access the components on the network.
Cannot access Windows Media Player 11.	You are currently logged onto the domain through your PC with Windows XP installed.	Instead of logging onto the domain, log onto the local machine (page 69).
Cannot listen to Internet radio stations	The firewall settings for components on the network are currently in operation.	Check the firewall settings for components on the network.
	You are currently disconnected from the Internet.	Check the connection settings for components on the network, and consult with your network service provider if necessary (page 74).
	The broadcasts from an Internet radio station are stopped or interrupted.	There are cases where you cannot listen to some Internet radio stations even when they are listed in the list of Internet radio stations on this receiver (page 70 and 125).
The Home Media Gallery cannot be operated with the buttons on the remote control.	The remote control is not currently set to the Home Media Gallery mode.	Press HOME MEDIA GALLERY to set the remote control to the Home Media Gallery mode (page 69).

About status messages

Refer to the following information when you come up with a status message while operating the Home Media Gallery.

Status messages	Descriptions
Please Wait	A component on the network, including a PC, is currently being connected. Wait for a while.
Connection Down	The selected category or Internet radio station cannot be accessed.
File Format Error	Cannot be played back for some reasons.
Track Not Found	The selected song has not been found anywhere on the network.
Server Error	The selected server cannot be accessed.
Server Disconnected	The server has been disconnected.
empty	There are no files stored in the selected folder.
Preset Not Stored	The selected Internet radio station is not currently registered and saved.
Out of Range	The value entered is beyond the permitted range of the network settings.
License Error	The license for the contents to be played back is invalid.
Item Already Exists	This is displayed when the file you have attempted to register in the Favorites folder has already been registered.
Favorite List Full	This is displayed when you have attempted to register a file in the Favorites folder but the Favorites folder is already full.

USB interface

Symptoms	Causes	Remedies
The folders/files stored on a USB memory device are not displayed.	The folders/files are currently stored in a region other than the FAT (File Allocation Table) region.	Store the folders/files in the FAT region.
	The number of levels in a folder is more than 8.	Limit the maximum number of levels in a folder to 8 (page 49).
	There are more than 30 000 folders/files stored in a USB memory device.	Limit the maximum number of folders/files stored in a USB memory device to 30 000 (page 49).
	The audio files are copyrighted.	Copyrighted audio files stored on a USB memory device cannot be played back (page 49).
A USB memory device is not recognized.	The USB memory device does not support the mass storage class specifications.	Try using a USB memory device compatible with the mass storage class specifications. Note that there are cases where even the audio files stored on a USB memory device compatible with the mass storage class specifications are not played back on this receiver (page 49).
	Some formats of a USB memory device, including NTFS, and HFS, cannot be played back on this receiver.	Check whether the format of your USB memory device is either FAT 12, FAT 16 or FAT 32. Note that the NTFS, and HFS formats cannot be played back on this receiver (page 49).
	The USB memory device is not connected properly.	Check the USB memory device connection, then switch on this receiver (page 40).
	A USB hub is currently being used.	This receiver does not support a USB hub (page 49).
	This receiver recognizes the USB memory device as a fraud.	Switch off and on again this receiver.
	A USB memory device is connected and displayed, but the audio files stored on the USB memory device cannot be played back.	The file format cannot be properly played back on this receiver.

XM radio messages

Status messages	Cause	Action
Check XM Tuner	The XM Mini-Tuner is not installed or not fully seated in the XM Mini-Tuner Home Dock or the XM Mini-Tuner Dock is not connected to this receiver.	Confirm the XM Mini-Tuner is fully seated in the dock and check the XM Mini-Tuner Home Dock cable is connected to this receiver.
Check Antenna	The XM antenna is not connected to the XM Mini-Tuner Home Dock or the XM antenna cable is damaged.	Check that the XM antenna is securely connected to the XM Mini-Tuner Home Dock and check the antenna cable for damage. Replace the XM antenna if the cable is damaged.
Loading	The XM Mini-Tuner is acquiring audio or program information from the XM satellite signal. This message can also occur in weak XM signal conditions. Note that this receiver may not respond to some buttons while this message is displayed.	This message should disappear in a few seconds in good signal conditions. If you see this message often, reposition the XM antenna for better signal reception. Use the Antenna Aiming option to optimize the antenna position.
No Signal	The XM Mini-Tuner is not receiving the XM satellite signal. Something may be blocking the XM antenna's view of the satellites or the antenna is not properly aimed.	Check for antenna obstructions and reposition the XM antenna to get better signal reception. Use the Antenna Aiming option to optimize the antenna position. See instructions supplied with the XM Mini-Tuner and Home Dock for antenna installation information.
Off Air	The XM channel you selected is not currently broadcasting.	Check back later.
CH Unauthorized	You selected an XM channel that is blocked or cannot be received with your XM subscription package.	Consult the latest channel guide at www.xmradio.com for the current list of channels. For information on receiving this channel, visit www.xmradio.com or contact XM Satellite Radio at 1-800-967-2346.
CH Unavailable	The selected channel is not available. The channel may have been reassigned to a different channel number. This message may occur initially with a new radio or a radio that has not received XM's signal for an extended period.	Consult the latest channel guide at www.xmradio.com for the current list of channels. For cases of a new radio or a radio that has not received XM's signal for an extended period, allow the radio to receive the XM satellite signal for at least 5 minutes and then try to select the channel again.
-----	No artist name or song title is available for this selection.	No action required.
Upgrade XM Tuner	The connected XM CNP-1000 is incompatible. This receiver features advanced technology that is designed for use with the XM Mini-Tuner.	Contact XM Listener Care (1-800-967-2346) and ask about upgrading your XM CNP-1000 to an XM Mini-Tuner. Have this receiver's model name and CNP-1000 XM Radio ID number ready beforehand, and explain that this receiver is displaying the message Upgrade XM Tuner . If you already have an XM Mini-Tuner connected and you see this message, turn off this receiver, make sure the XM Mini-Tuner is properly seated in the Mini-Tuner Home Dock, and then turn this receiver on again. If the message reappears, contact XM Listener Care and explain the issue that you're experiencing and the corrective actions you've tried.
XM Power Error	A short-circuit occurring in the antenna or surrounding antenna cable.	Make sure that there is nothing unusual with the antenna or antenna cable. Switch the power off, then back on again.

SIRIUS radio messages

Status messages	Cause	Action
Antenna Error	The SIRIUS antenna is not properly connected.	Check that the antenna cable is attached securely.
Check Sirius Tuner	The SiriusConnect™ tuner is not properly connected.	Check that the 8 pin mini DIN cable and AC Adapter are attached securely.
Acquiring Signal	The SIRIUS signal is too weak at the current location.	Check for antenna obstructions and reposition the SIRIUS antenna to get better signal reception. Use the Antenna Aiming option to optimize the antenna position.
Subscription Updating	Unit is updating subscription.	Wait until the encryption code has been updated.
Updating Channels	Unit is updating channels.	Wait until the encryption code has been updated.
Invalid Channel	Selected channel is not available/does not exist.	Select another channel.
Firmware Updating	The SiriusConnect™ tuner's firmware is being updated.	Wait for updating to finish.

If the problem is not solved after the troubleshooting above, if the screen freezes unexpectedly or if the buttons on the remote control or front panel stop working completely, do the following:

- Press **⏻ STANDBY/ON** on the front panel to turn off the power, then turn the power back on.
- If the power cannot be turned off, press and hold **⏻ STANDBY/ON** on the front panel for over 10 seconds. The power will turn off. (In this case, the various settings made on the receiver may be cleared.)

Surround sound formats

Below is a brief description of the main surround sound formats you'll find on DVDs, satellite, cable and terrestrial broadcasts, and video cassettes.

Dolby

The Dolby technologies are explained below. See www.dolby.com for more detailed information.



Dolby Digital

Dolby Digital is a multichannel digital audio coding system widely used in cinemas, and in the home for DVD and digital broadcast soundtracks. It can deliver up to six discrete audio channels, comprising five full range channels and a special LFE (low frequency effects) channel used mainly for deep, rumbling sound effects; hence the term "5.1-channel" Dolby Digital.

In addition to the format features above, Dolby Digital decoders offer downmixing for compatibility with mono, stereo and Dolby Pro Logic audio from a number of bit rates and channels. Another feature, called Dialog Normalization, attenuates programs based on the average level of dialog in a program relative to its peak level (also known as Dialnorm) in order to achieve uniform playback level.

Dolby Digital Surround EX

Dolby Digital Surround EX (the EX stands for EXtended) is an extension of Dolby Digital encoding whereby a surround back channel is matrixed into the surround left/right channels for 6.1 channel playback. This allows for compatibility with Dolby Digital 5.1 channel decoding, as well as for decoding using Dolby Digital EX.

Dolby Pro Logic IIx and Dolby Surround

Dolby Pro Logic IIx is an improved version of the Dolby Pro Logic II (and Dolby Pro Logic) *decoding* system. Using the innovative "steering logic" circuit, this system extracts surround sound from sources as follows:

- **Dolby Pro Logic** – 4.1 channel sound (mono surround) from any stereo source
- **Dolby Pro Logic II** – 5.1 channel sound (stereo surround) from any stereo source
- **Dolby Pro Logic IIx** – 6.1 or 7.1 channel sound (stereo surround and surround back) from two channel or 5.1 (and 6.1) channel sources

With two channel sources, the ".1" subwoofer channel is generated by bass management in the receiver.

Dolby Surround is an *encoding* system which embeds surround sound information within a stereo soundtrack, which a Dolby Pro Logic decoder can then use for enhanced surround listening with greater sound detail.

Dolby Digital Plus

Dolby Digital Plus is the next-generation audio technology for all high-definition programming and media. It combines the efficiency to meet future broadcast demands with the power and flexibility to realize the full audio potential expected in the upcoming high-definition era. Built on Dolby Digital, the multi-channel audio standard for DVD and HD broadcasts worldwide, Dolby Digital Plus was designed for the next-generation A/V receivers but remains fully compatible with all current A/V receivers.

Dolby Digital Plus delivers multi-channel audio programs of up to 7.1 channels (*) and supports multiple programs in a single encoded bitstream with the maximum bit rate potential of up to 6 Mbps and the maximum bit rate performance of up to 3 Mbps on HD DVD and 1.7 Mbps on Blu-ray Disc, and it outputs Dolby Digital bitstreams for playback on existing Dolby Digital systems. Dolby Digital Plus can accurately reproduce the sound originally intended by directors and producers.

It also features multi-channel sound with discrete channel output, interactive mixing and streaming capability in advanced systems. Supported by High-Definition Media Interface (HDMI), a single-cable digital connection is possible for high-definition audio and video.

Dolby TrueHD

Dolby TrueHD is the next-generation lossless encoding technology developed for high-definition optical discs in the upcoming era. Dolby TrueHD delivers tantalizing sound that is bit-for-bit identical to the studio master, unlocking the true high-definition entertainment experience on high-definition optical discs in the next generation. When coupled with high-definition video, Dolby TrueHD offers an unprecedented home theater experience with stunning sound and high-definition picture.

It supports bit rates of up to 18 Mbps and records up to 8 full-range channels (*) individually with 24-bit/96 kHz audio. It also features extensive metadata including dialogue normalization and dynamic range control. Supported by High-Definition Media Interface (HDMI), a single-cable digital connection is possible for high-definition audio and video.

HD DVD and Blu-ray Disc standards currently limit their maximum number of audio channels to eight, whereas Dolby Digital Plus and Dolby TrueHD support more than eight audio channels.

Manufactured under license from Dolby Laboratories. Dolby, Pro Logic, Surround EX and the double-D symbol are trademarks of Dolby Laboratories.

DTS

The DTS technologies are explained below. See www.dtstech.com for more detailed information.



DTS Digital Surround

DTS Digital Surround is a 5.1-channel audio coding system from DTS Inc. now widely used for DVD-Video, DVD-Audio, 5.1 music discs, digital broadcasts, and video games. It can deliver up to six discrete audio channels, comprising five full range channels, including an LFE channel. Higher sound quality is achieved through the use of a low compression rate, and high rates of transmittance during playback.

DTS-ES

DTS-ES (the ES stands for Extended Surround) is a decoder that is capable of decoding both DTS-ES Discrete 6.1 and DTS-ES Matrix 6.1 encoded sources. DTS-ES Discrete 6.1 gives 'true' 6.1 channel sound, with a completely separate (discrete) surround back channel. DTS-ES Matrix 6.1 has a surround back channel matrixed into the surround left/right channels. Both sources are also compatible with a conventional DTS 5.1 channel decoder.

DTS Neo:6

DTS Neo:6 can generate 7.1 channel surround sound from any matrixed stereo source (such as video or TV) and from 5.1 channel sources. It uses both the channel information already encoded into the source, as well as its own processing to determine channel localization (with two channel sources, the ".1" subwoofer channel is generated by bass management in the receiver). Two modes (Cinema and Music) are available using DTS Neo:6 with two channel sources.

DTS 96/24

DTS 96/24 is an extension of the original DTS Digital Surround which offers high quality 96 kHz/24-bit audio using a DTS 96/24 decoder. This format is also fully backward compatible with all existing decoders. This means that DVD players can play this software using a conventional DTS 5.1 channel decoder.

DTS-EXPRESS

DTS-EXPRESS is a low-bitrate encoding technology supporting up to 5.1 channels with fixed data transfer rates. This format is incorporated with sub audio on HD DVD and secondary audio on Blu-ray Disc while boasting the potential applicability to upcoming broadcasts and memory audio contents.

DTS-HD Master Audio

DTS-HD Master Audio is a technology that delivers master audio sources recorded in a professional studio to listeners without any loss of data, preserving audio quality. DTS-HD Master Audio adopts variable data transfer rates, facilitating data transfer to the maximum rate of 24.5 Mbps in the Blu-ray disc format, 18.0 Mbps in the HD-DVD format, which by far exceeds that of a standard DVD. These high data transfer rates enable lossless transmission of 96 kHz/24-bit 7.1-channel audio sources without deteriorating the quality of the original sound. DTS-HD Master Audio is an irreplaceable technology that can reproduce sound faithfully as intended by the creator of music or movies.

Manufactured under license under U.S. Patent #'s: 5,451,942; 5,956,674; 5,974,380; 5,978,762; 6,226,616; 6,487,535; 7,212,872; 7,333,929; 7,392,195; 7,272,567 & other U.S. and worldwide patents issued & pending. DTS is a registered trademark and the DTS logos, Symbol, DTS-HD and DTS-HD Master Audio are trademarks of DTS, Inc. © 1996-2008 DTS, Inc. All Rights Reserved.

Windows Media Audio 9 Professional

Windows Media Audio 9 Professional (WMA9 Pro) is a discrete surround format developed by Microsoft Corporation.



Windows Media and the Windows logo are trademarks or registered trademarks of Microsoft Corporation in the United States and/or other countries.

About iPod



“Made for iPod” means that an electronic accessory has been designed to connect specifically to iPod and has been certified by the developer to meet Apple performance standards.

“Works with iPhone” means that an electronic accessory has been designed to connect specifically to iPhone and has been certified by the developer to meet Apple performance standards.

Apple is not responsible for the operation of this device or its compliance with safety and regulatory standards.

iPod is a trademark of Apple Inc., registered in the U.S. and other countries. iPhone is a trademark of Apple Inc.

About THX

The THX technologies are explained below. See www.thx.com for more detailed information.

THX

SELECT 2 PLUS

RECOMMENDED USE

Medium Sized Home Theater or Living Room

THX CERTIFICATION FEATURES

THX Loudness Plus:

- Multichannel Spectral Balancing
- Dynamic Ambience Preservation

THX Surround EX

THX Cinema, Music, Games Modes:

- Re-Equalization
- Timbre Matching
- Adaptive Decorrelation
- ASA Technology

Boundary Gain Compensation

ADDITIONAL THX TECHNOLOGIES

Neural-THX Surround

THX PERFORMANCE

Capable of THX Reference Level up to 9 feet (3 meters) viewing/listening distance

Visit www.thx.com for further technical details.

- **THX Cinema processing**

THX is an exclusive set of standards and technologies established by THX Ltd. THX grew from George Lucas' personal desire to make your experience of the film soundtrack, in both movie theatres and in your home theatre, as faithful as possible to what the director intended. Movie soundtracks are mixed in special movie theatres called dubbing stages and are designed to be played back in movie theatres with similar equipment and conditions. This same soundtrack is then transferred directly onto Laserdisc, VHS tape, DVD, etc., and is not changed for playback in a small home theatre environment. THX engineers developed patented technologies to accurately translate the sound from the movie theatre environment into the home, correcting the tonal and spatial errors that occur. On this product, when the THX indicator is on, THX features are automatically added in Cinema modes (e.g. THX Cinema, THX Surround EX).

- **Re-Equalization**

The tonal balance of a film soundtrack will be excessively bright and harsh when played back over audio equipment in the home because film soundtracks were designed to be played back in large movie theaters using very different professional equipment. Re-Equalization restores the correct tonal balance for watching a movie soundtrack in a small home environment.

- **Timbre Matching**

The human ear changes our perception of a sound depending on the direction from which the sound is coming. In a movie theatre, there is an array of surround speakers so that the surround information is all around you. In a home theatre, you use only two speakers located to the side of your head. The Timbre Matching feature filters the information going to the surround speakers so that they more closely match the tonal characteristics of the sound coming from the front speakers. This ensures seamless panning between the front and surround speakers.

- **Adaptive Decorrelation**

In a movie theatre, a large number of surround speakers help create an enveloping surround sound experience, but in a home theatre there are usually only two speakers. This can make the surround speakers sound like headphones that lack spaciousness and envelopment. The surround sounds will also collapse into the closest speaker as you move away from the middle seating position. Adaptive Decorrelation slightly changes one surround channel's time and phase relationship with respect to the other surround channel. This expands the listening position and creates—with only two speakers—the same spacious surround experience as in a movie theatre.

- **THX Select2 Plus**

Before any home theatre component can be THX Select2 Plus certified, it must incorporate all the features above and also pass a rigorous series of quality and performance tests. Only then can a product feature the THX Select2 Plus logo, which is your guarantee that the Home Theatre products you purchase will give you superb performance for many years to come. THX Select2 Plus requirements cover every aspect of the product including pre-amplifier and power amplifier performance and operation, and hundreds of other parameters in both the digital and analog domain.

- **THX Surround EX**

THX Surround EX - Dolby Digital Surround EX is a joint development of Dolby Laboratories and the THX Ltd. In a movie theater, film soundtracks that have been encoded with Dolby Digital Surround EX technology are able to reproduce an extra channel which has been added during the mixing of the program. This channel, called Surround Back, places sounds behind the listener in addition to the currently available front left, front center, front right, surround right, surround left and subwoofer channels. This additional channel provides the opportunity for more detailed imaging behind the listener and brings more depth, spacious ambience and sound localization than ever before. Movies that were created using the Dolby Digital Surround EX technology, when released into the home consumer market may exhibit wording to that effect on the packaging. A list of movies created using this technology can be found on the Dolby web site at www.dolby.com.

Only amplifier and controller products bearing the THX Surround EX logo, when in the THX Surround EX mode, faithfully reproduce this new technology in the home.

This product may also engage the "THX Surround EX" mode during the playback of 5.1 channel material that is not Dolby Digital Surround EX encoded. In such case the information delivered to the Surround Back channel will be program dependent and may or may not be very pleasing depending on the particular soundtrack and the tastes of the individual listener.

- **Advanced Speaker Array (ASA)**

ASA is a proprietary THX technology which processes the sound fed to 2 side and 2 back surround speakers to provide the optimal surround sound experience. When you set up your home theater system using all eight speaker outputs (Left, Center, Right, Surround Right, Surround Back Right, Surround Back Left, Surround Left and Subwoofer) placing the two Surround Back speakers close together facing the front of the room will provide the largest sweet spot. If for practical reasons you have to place the Surround Back speakers apart, you will need to go THX Audio Set-up screen and choose the setting that most closely corresponds to the speaker spacing, which will re-optimize the surround sound-field.

ASA is used in three new modes: THX Select2 CINEMA, THX Select2 MUSIC and THX Select2 GAMES.

- **Boundary Gain Compensation™**

Depending on the listener's and the subwoofer's position, the listener may experience an excessive bass effect. This feature compensates for excessive bass resulting from a boundary gain effect. This feature

is designed to operate when used with a subwoofer certified to THX Select2™ specifications.

- **THX Music**

For the replay of multi-channel music the THX MusicMode should be selected. In this mode THX ASA processing is applied to the surround channels of all 5.1 encoded music sources such as DTS, Dolby Digital and DVD-Audio to provide a wide stable rear soundstage.

- **THX Games**

For the replay of stereo and multi-channel game audio the THX Games Mode should be selected. In this mode THX ASA processing is applied to the surround channels of all 5.1 and 2.0 encoded game sources such as analog, PCM, DTS and Dolby Digital. This accurately places all game audio surround information, providing a full 360 degree playback environment. THX Games Mode is unique as it gives you a smooth transition of audio in all points of the surround field.

- **THX Loudness Plus Description**

THX Loudness Plus is a new volume control technology featured in THX Select2 Plus™ Certified amplifiers. With THX Loudness Plus, home theater audiences can now experience the rich details in a surround mix at any volume level. A consequence of turning the volume below Reference Level is that certain sound elements can be lost or perceived differently by the listener. THX Loudness Plus compensates for the tonal and spatial shifts that occur when the volume is reduced by intelligently adjusting ambient surround channel levels and frequency response. This enables users to experience the true impact of soundtracks regardless of the volume setting. THX Loudness Plus is automatically applied when listening in any THX listening mode. The new THX Cinema, THX Music, and THX Games modes are tailored to apply the proper THX Loudness Plus settings for each type of content.

- **THX Select2 Cinema**

THX Select2 Cinema mode plays 5.1 movies using all 8 speakers giving you the best possible movie watching experience. In this mode, ASA processing blends the side surround speakers and back surround speakers providing the optimal mix of ambient and directional surround sounds.

DTS-ES (Matrix and 6.1 Discrete) and Dolby Digital Surround EX encoded soundtracks will be automatically detected in Select2 Cinema mode if the appropriate flag has been encoded.

Some Dolby Digital Surround EX soundtracks are missing the digital flag that allows automatic switching. If you know that the movie that you are watching is encoded in Surround EX, you can manually select the THX Surround EX playback mode, otherwise THX Select2 Cinema mode will apply ASA processing to provide optimum replay.

- **THX Select2 Music**

For the playback of multi-channel music the THX Select2 Music mode should be selected. In this mode THX ASA processing is applied to the surround channels of all 5.1 encoded music sources such as DTS, Dolby Digital and DVD-Audio to provide a wide stable rear soundstage.

- **THX Select2 Games**

For the playback of stereo and multi-channel game audio the THX Select2 Games mode should be selected. In this mode THX ASA processing is applied to the surround channels of all 5.1 and 2.0 encoded game sources such as analog, PCM, DTS and Dolby Digital. This accurately places all game audio surround information, providing a full 360 degree playback environment. THX Select2 Games mode is unique as it gives you a smooth transition of audio in all points of the surround field.

THX, the THX logo and Select2 Plus are trademarks of THX Ltd. which may be registered in some jurisdictions. All rights reserved. All other trademarks are the property of their respective owners.

About Neural – THX Surround



Neural-THX® Surround is taking surround sound to the next level. This revolutionary new technology delivers the rich envelopment and discrete image detail of surround sound in a format that is fully compatible with stereo from various content sources. Neural-THX Surround enables 5.1, 6.1 and 7.1-channel support for gaming, movies and digital music. By unmasking the audio details, typically lost by other playback modes, audiences will experience the deep ambience and subtle details of movies, music and games.

Neural-THX Surround has been chosen as the official surround sound format for XM Satellite Radio's "XM HD Surround," TV sports broadcasting, 7.1 games, Music Direct Internet streaming as well as leading FM/HD radio stations worldwide. And with this technology being used by sound designers during content creation, as well as embedded into playback devices, Neural-THX Surround promises a listening experience that is true to the original mix.

For additional information, please visit www.neuralsurround.com. This product is manufactured under license from Neural Audio Corporation and THX Ltd. PIONEER Corporation hereby grants the user a non-exclusive, non-transferable, limited right of use to this product under USA and foreign patent, patent pending and other technology or trademarks owned by Neural Audio Corporation and THX Ltd. "Neural Surround", "Neural Audio", "Neural" and "NRL" are trademarks and logos owned by Neural Audio Corporation, THX is a trademark of THX Ltd., which may be registered in some jurisdictions. All rights reserved.

About SIRIUS and XM



SIRIUS, XM and all related marks and logos are trademarks of Sirius XM Radio Inc. and its subsidiaries. All other marks and logos are the property of their respective owners. All rights reserved. SIRIUS and XM subscriptions sold separately. Taxes and a one-time activation fee may apply. XM tuners and home docks or SIRIUS tuners (each sold separately) are required to receive the SIRIUS or XM satellite radio service. All programming and fees subject to change. It is prohibited to copy, decompile, disassemble, reverse engineer, hack, manipulate or otherwise make available any technology or software incorporated in receivers compatible with the SIRIUS or XM Satellite Radio Systems. Service not available in Alaska and Hawaii.

SIRIUS, XM and all related marks and logos are trademarks of Sirius XM Radio Inc. and its subsidiaries. All rights reserved. Service not available in Alaska and Hawaii.

Record the SiriusConnect™ tuner ID below for reference.

--	--	--	--	--	--	--	--	--	--	--	--	--	--	--	--

Record the XM Radio ID below for reference.

--	--	--	--	--	--	--	--

Note: The XM Radio ID does not use the letters "I", "O", "S" or "F".

About FLAC

FLAC Decoder

Copyright © 2000, 2001, 2002, 2003, 2004, 2005, 2006,
2007 Josh Coalson

Redistribution and use in source and binary forms, with or without modification, are permitted provided that the following conditions are met:

- Redistributions of source code must retain the above copyright notice, this list of conditions and the following disclaimer.
- Redistributions in binary form must reproduce the above copyright notice, this list of conditions and the following disclaimer in the documentation and/or other materials provided with the distribution.
- Neither the name of the Xiph.org Foundation nor the names of its contributors may be used to endorse or promote products derived from this software without specific prior written permission.

THIS SOFTWARE IS PROVIDED BY THE COPYRIGHT HOLDERS AND CONTRIBUTORS "AS IS" AND ANY EXPRESS OR IMPLIED WARRANTIES, INCLUDING, BUT NOT LIMITED TO, THE IMPLIED WARRANTIES OF MERCHANTABILITY AND FITNESS FOR A PARTICULAR PURPOSE ARE DISCLAIMED. IN NO EVENT SHALL THE FOUNDATION OR CONTRIBUTORS BE LIABLE FOR ANY DIRECT, INDIRECT, INCIDENTAL, SPECIAL, EXEMPLARY, OR CONSEQUENTIAL DAMAGES (INCLUDING, BUT NOT LIMITED TO, PROCUREMENT OF SUBSTITUTE GOODS OR SERVICES; LOSS OF USE, DATA, OR PROFITS; OR BUSINESS INTERRUPTION) HOWEVER CAUSED AND ON ANY THEORY OF LIABILITY, WHETHER IN CONTRACT, STRICT LIABILITY, OR TORT (INCLUDING NEGLIGENCE OR OTHERWISE) ARISING IN ANY WAY OUT OF THE USE OF THIS SOFTWARE, EVEN IF ADVISED OF THE POSSIBILITY OF SUCH DAMAGE.

Auto Surround, ALC and Stream Direct with different input signal formats

The following charts show what you will hear with different input signal formats, depending on the Stream Direct mode (see *Using Stream Direct* on page 60) you have selected.

Stereo (2 channel) signal formats

Input signal format	Auto Surround / ALC / DIRECT	PURE DIRECT
Surround Back speaker(s): Connected		
Dolby Digital Surround	ⓧ Pro Logic IIx MOVIE	ⓧ Pro Logic IIx MOVIE
DTS Surround	Neo:6 CINEMA	Neo:6 CINEMA
Other stereo sources	Stereo playback	Stereo playback
Analog sources	<i>As above</i>	ANALOG DIRECT (stereo)
PCM sources	<i>As above</i>	Stereo playback
DVD-A sources	<i>As above</i>	<i>As above</i>
SACD sources	<i>As above</i>	<i>As above</i>
Surround Back speaker(s): Not connected		
Dolby Digital Surround	ⓧ Pro Logic II MOVIE	ⓧ Pro Logic II MOVIE
DTS Surround	Neo:6 CINEMA	Neo:6 CINEMA
Other stereo sources	Stereo playback	Stereo playback
Analog sources	<i>As above</i>	ANALOG DIRECT (stereo)
PCM sources	<i>As above</i>	Stereo playback
DVD-A sources	<i>As above</i>	<i>As above</i>
SACD sources	<i>As above</i>	<i>As above</i>

Multichannel signal formats

Input signal format	Auto Surround / ALC	PURE DIRECT / DIRECT
Surround Back speaker(s): Connected		
Dolby Digital EX (6.1 channel flagged)	Dolby Digital EX ⓧ Pro Logic IIx MOVIE^a	Dolby Digital EX ⓧ Pro Logic IIx MOVIE^a
DTS-ES (6.1 channel sources/6.1 channel flagged)	DTS-ES (Matrix/Discrete)	DTS-ES (Matrix/Discrete)
DTS sources (5.1 channel encoding)	DTS+Neo:6	Straight decoding
DTS-HD sources	Straight decoding	<i>As above</i>
Other 6.1/7.1 channel sources	<i>As above</i>	<i>As above</i>
Other 5.1 channel sources	Dolby Digital EX ⓧ Pro Logic IIx MOVIE^a	<i>As above</i>
Surround Back speaker(s): Not connected		
DVD-A sources/Multi-ch PCM	Straight decoding	Straight decoding
SACD sources (5.1 channel encoding)	<i>As above</i>	<i>As above</i>
Other 5.1/6.1/7.1 channel sources	<i>As above</i>	<i>As above</i>

a.Unavailable with only one surround back speaker connected.

Specifications

Amplifier section

Continuous average power output of 140 watts* per channel, min., at 8 ohms, from 20 Hz to 20 000 Hz with no more than 0.09 % total harmonic distortion.**

Multi channel simultaneous power output (1 kHz, 1 %, 8 Ω)	
7 ch total	700 W
Continuous Power Output (20 Hz to 20 kHz, 8 Ω, 0.09 %)	
Front	140 W + 140 W
Center	140 W
Surround	140 W + 140 W
Surround back	140 W + 140 W
Continuous Power Output (1 kHz, 6 Ω, 1.0 %)	
Front	180 W + 180 W
Center	180 W
Surround	180 W + 180 W
Surround back	180 W + 180 W
Total harmonic distortion	0.05 %
	(20 Hz to 20 kHz, 130 W, 8 Ω)

* Measured pursuant to the Federal Trade Commission's Trade Regulation rule on Power Output Claims for Amplifiers
 ** Measured by Audio Spectrum Analyzer

Audio Section

Input (Sensitivity/Impedance)	
PHONO MM	4.2 mV/47 kΩ
LINE	335 mV/47 kΩ
Output (Level/Impedance)	
REC	335 mV/2.2 kΩ
Signal-to-Noise Ratio (IHF, short circuited, A network)	
LINE	103 dB
Signal-to-Noise Ratio [EIA, at 1 W (1 kHz)]	
LINE	83 dB

Tuner Section

Frequency Range (FM)	87.5 MHz to 108 MHz
Antenna Input (FM)	75 Ω unbalanced
Frequency Range (AM)	530 kHz to 1700 kHz
Antenna (AM)	Loop antenna (balanced)

Video Section

Signal level	
Composite/S-Video	1 Vp-p (75 Ω)
Component Video	Y: 1.0 Vp-p (75 Ω), PB, PR: 0.7 Vp-p (75 Ω)
Corresponding maximum resolution	
Component Video	1080p (1125p) (Video convert off)

Digital In/Out Section

HDMI terminal	19-pin (Not DVI)
HDMI output type	.5 V, 100 mA
USB terminal	USB2.0 Full Speed (Type A)
iPod terminal	USB, and Video (Composite)
SIRIUS antenna cable	8-pin mini DIN cable

Network Section

LAN terminal	10 BASE-T/100 BASE-TX
--------------	-----------------------

Integrated control section

Control (SR) terminal	Ø 3.5 Mini-jack (MONO)
Control (IR) terminal	Ø 3.5 Mini-jack (MONO)
IR signal	High Active (High Level: 2.0 V)
12 V Trigger terminal	Ø 3.5 Mini-jack (MONO)
12 V Trigger output type	12 V, Total 50 mA
RS-232C cable type	9-pin, cross type, female-female

Miscellaneous

Power requirements	AC 120 V, 60 Hz
Power consumption	330 W
In standby	0.4 W (KURO LINK OFF) 0.6 W (KURO LINK ON)
Dimensions	420 (W) mm x 200 (H) mm x 460 (D) mm (16 ⁹ / ₁₆ (W) in. x 7 ⁷ / ₈ (H) in. x 18 ¹ / ₈ (D) in.)
Weight (without package)	18.5 kg (40.8 lb)

Furnished Parts Number

MCACC Setup microphone (APM7009)	1
Remote control unit (AXD7542)	1
AA/IEC R6 dry cell batteries	2
iPod cable (ADE7129)	1
AM loop antenna	1
FM wire antenna	1
Power cord (ADG7111)	1
Warranty card	1
These operating instructions	

Note

- Specifications and the design are subject to possible modifications without notice, due to improvements.

Cleaning the unit

- Use a polishing cloth or dry cloth to wipe off dust and dirt.
- When the surface is dirty, wipe with a soft cloth dipped in some neutral cleanser diluted five or six times with water, and wrung out well, and then wipe again with a dry cloth. Do not use furniture wax or cleansers.
- Never use thinners, benzene, insecticide sprays or other chemicals on or near this unit, since these will corrode the surface.

This product includes FontAvenue® fonts licensed by NEC corporation.
 FontAvenue is a registered trademark of NEC Corporation

Index

Numerics

12V trigger **38**

A

Acoustic Cal EQ **105**
 Acoustic Calibration EQ **82**
 Acoustic Calibration EQ Adjust **101**
 Acoustic Calibration EQ Professional **101**
 Advanced MCACC **95–107**
 Output PC **38, 106**
 Advanced surround **59**
 Analog attenuator **86**
 Aspect **84**
 Audio cable **24**
 AUDIO PARAMETER **82**
 Auto delay **83**
 Auto level control (ALC) **57, 133**
 Auto MCACC **96**
 Auto surround **57, 133**

B

Bass **82**
 Bi-amp **19, 23, 24, 109**
 Bi-wiring **23**
 Brightness **84**

C

Center Image **83**
 Center Width **83**
 Channel Level **104, 110**
 Chroma Level **84**
 Contrast **84**
 CONTROL jack **37**

D

Data Management **106**
 Deep Color **29**
 Default system settings **88**
 Demo **95**
 Detail **84**
 Dialog Enhancement **82**
 Digital Noise Reduction **82**
 Digital Video Conversion **84**
 Dimension **83**
 Display **15, 87, 121**
 Dolby **57, 127**
 DTS **57, 128**
 Dual Mono **82**

Dynamic Range Control **82**

E

Effect **83**

F

Fine Channel Level **99**
 Fine Speaker Distance **100**
 Flicker Reduction **114**
 Front Stage Surround Advance **60**
 Full Band Phase Control **42, 63**

H

HDCP **29**
 HDMI **26–29, 39, 46, 79–81, 87, 122**
 HDMI Audio **83**
 Hue **84**

I

Input function **46**
 Default and possible settings **45**
 Input Setup **44–45**
 Input signal **63**
 iPod **40, 47–48, 129**
 Switching controls **48**
 IR jack **37**

K

KURO LINK **29, 79–81**

L

LFE Attenuate **83**
 Loudness **82**

M

Manual MCACC **98**
 Manual speaker setup **108**
 MCACC Data **104**
 MCACC preset **62, 82, 107**
 Midnight **82**
 Multi Zone **19, 22, 24, 35–36, 85, 109, 113**
 Multichannel analog input **31, 47, 112**

N

Neural THX **52, 131**

O

Optimum Surround **57**
 OSD Language (GUI) **42**

P

Panorama **83**
 Phase control **63**
 Placing **20**
 Play **46**
 Power cord **41**
 Power ON Level **113**
 PQLS **81**
 Pre-out **33**
 Progressive Motion **84**
 Pure direct **60**
 PureCinema **84**

R

Recording **86**
 Remote control **11, 12, 89–94, 114, 121**
 Reset **88**
 Resolution **84**

S

SACD Gain **83**
 Setup microphone **97**
 Sharpness **84**
 Sleep timer **86**
 Sound Delay **82**
 Sound Retriever **82**
 Speaker **19–24, 115**
 Speaker B **19, 22, 24, 84, 109**
 Speaker Distance **105, 111**
 Speaker Setting **104, 109**
 Standard surround **57**
 Standing Wave **82, 100**
 Status **87**
 Stereo **59**
 Stream direct **60, 133**
 Surround back channel processing **61**
 Surround back speaker **109**
 Synchronized amp mode **81**
 System Setup **108**

T

THX **20, 96, 111, 129**
 Home THX **58**
 Tone Control **82**
 Treble **82**
 Troubleshooting **116**
 Tuner **33, 52–53**

U

Up Mix **61**
 USB **40, 49–51, 125**
 Playable file formats **51**

V

Video cable **25**
 Video converter **25**
 VIDEO PARAMETER **83**
 Volume Limit **113**

W

WMA9 **129**
 WMA9 Pro **32**

X

x.v.Color **29**
 X-Curve **111**

Y

YNR **84**



Dear Customer:

Selecting fine audio equipment such as the unit you've just purchased is only the start of your musical enjoyment. Now it's time to consider how you can maximize the fun and excitement your equipment offers. This manufacturer and the Electronic Industries Association's Consumer Electronics Group want you to get the most out of your equipment by playing it at a safe level. One that lets the sound come through loud and clear without annoying blaring or distortion-and, most importantly, without affecting your sensitive hearing.

Sound can be deceiving. Over time your hearing "comfort level" adapts to higher volumes of sound. So what sounds "normal" can actually be loud and harmful to your hearing. Guard against this by setting your equipment at a safe level BEFORE your hearing adapts.

To establish a safe level:

- Start your volume control at a low setting.
- Slowly increase the sound until you can hear it comfortably and clearly, and without distortion.

Once you have established a comfortable sound level:

- Set the dial and leave it there.

Taking a minute to do this now will help to prevent hearing damage or loss in the future. After all, we want you listening for a lifetime.

We Want You Listening For A Lifetime

Used wisely, your new sound equipment will provide a lifetime of fun and enjoyment. Since hearing damage from loud noise is often undetectable until it is too late, this manufacturer and the Electronic Industries Association's Consumer Electronics Group recommend you avoid prolonged exposure to excessive noise. This list of sound levels is included for your protection.

Decibel Level Example

30	Quiet library, soft whispers
40	Living room, refrigerator, bedroom away from traffic
50	Light traffic, normal conversation, quiet office
60	Air conditioner at 20 feet, sewing machine
70	Vacuum cleaner, hair dryer, noisy restaurant
80	Average city traffic, garbage disposals, alarm clock at two feet.

THE FOLLOWING NOISES CAN BE DANGEROUS UNDER CONSTANT EXPOSURE

90	Subway, motorcycle, truck traffic, lawn mower
100	Garbage truck, chain saw, pneumatic drill
120	Rock band concert in front of speakers, thunderclap
140	Gunshot blast, jet plane
180	Rocket launching pad

Information courtesy of the Deafness Research Foundation.



S001_En

Should this product require service in the U.S.A. and you wish to locate the nearest Pioneer Authorized Independent Service Company, or if you wish to purchase replacement parts, operating instructions, service manuals, or accessories, please call the number shown below.

1-800-421-1404

Please do not ship your product to Pioneer without first calling the Customer Support at the above listed number for assistance.

Pioneer Electronics Service, Inc.
P.O. BOX 1760, Long Beach,
CA 90801-1760, U.S.A.

For warranty information please see the Limited Warranty sheet included with your product.

Should this product require service in Canada, please contact a Pioneer Canadian Authorized Dealer to locate the nearest Pioneer Authorized Service Company in Canada. Alternatively, please contact the Customer Satisfaction Department at the following address:

Pioneer Electronics of Canada, Inc.
Customer Satisfaction Department
300 Allstate Parkway, Markham, Ontario L3R 0P2
1-877-283-5901
905-479-4411

For warranty information please see the Limited Warranty sheet included with your product.

Si ce produit doit être réparé au Canada, veuillez vous adresser à un distributeur autorisé Pioneer du Canada pour obtenir le nom du Centre de Service Autorisé Pioneer le plus près de chez-vous. Vous pouvez aussi contacter le Service à la clientèle de Pioneer:

Pioneer Électroniques du Canada, Inc.
Service Clientèle
300, Allstate Parkway, Markham, Ontario L3R 0P2
1-877-283-5901
905-479-4411

Pour obtenir des renseignements sur la garantie, veuillez vous reporter au feuillet sur la garantie restreinte qui accompagne le produit.

5018_C_EF

Register Your Product on

<http://www.pioneerelectronics.com> (US)

<http://www.pioneerelectronics.ca> (Canada)

PIONEER CORPORATION

4-1, Meguro 1-Chome, Meguro-ku, Tokyo 153-8654, Japan

PIONEER ELECTRONICS (USA) INC.

P.O. BOX 1540, Long Beach, California 90801-1540, U.S.A. TEL: (800) 421-1404

PIONEER ELECTRONICS OF CANADA, INC.

300 Allstate Parkway, Markham, Ontario L3R 0P2, Canada TEL: 1-877-283-5901, 905-479-4411

PIONEER EUROPE NV

Haven 1087, Keetberglaan 1, B-9120 Melsele, Belgium TEL: 03/570.05.11

PIONEER ELECTRONICS ASIACENTRE PTE. LTD.

253 Alexandra Road, #04-01, Singapore 159936 TEL: 65-6472-7555

PIONEER ELECTRONICS AUSTRALIA PTY. LTD.

178-184 Boundary Road, Braeside, Victoria 3195, Australia, TEL: (03) 9586-6300

PIONEER ELECTRONICS DE MEXICO S.A. DE C.V.

Bldv.Manuel Avila Camacho 138 10 piso Col.Lomas de Chapultepec, Mexico,D.F. 11000 TEL: 55-9178-4270

K002_B_En

Published by Pioneer Corporation.

Copyright © 2009 Pioneer Corporation.

All rights reserved.